

---

# DIRECTOR

---

## OPERATIONAL TEST & EVALUATION

---





---

# DIRECTOR

---

## OPERATIONAL TEST & EVALUATION

---

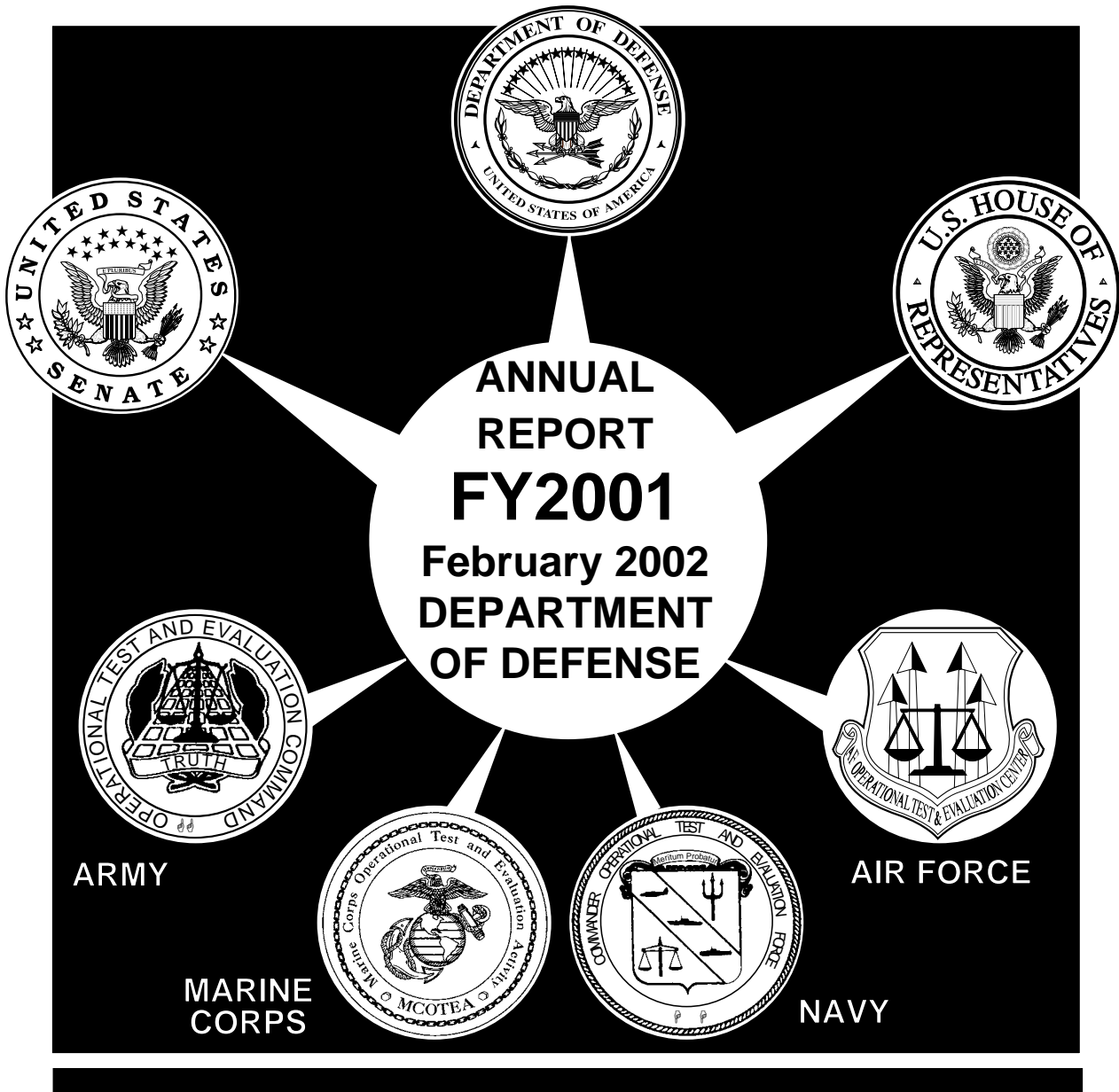

## **NOTICE**

This is an unclassified version of the FY 2001 Annual Report of the Director, Operational Test and Evaluation. In addition to this version, a classified annex is being submitted to the Secretary of Defense and the House and Senate Defense Committees pursuant to the provisions of Section 139, Title 10, U.S. Code.

This unclassified version has been published in response to Section 3013 of the Federal Acquisition Streamlining Act of 1994.



## DIRECTOR'S INTRODUCTION

I had the privilege of being nominated in May 2001 by the President to be the Director of Operational Test and Evaluation. I was subsequently confirmed by the Senate and sworn in as the DOT&E in July 2001. During my confirmation hearing before the Senate Armed Services Committee, Senator Levin emphasized to me that testing needed to be independent, fair, and reliable. Senator Warner made clear that testing was important at every level—from weapons to clothing—and that we did not need another M-16 type problem. Thus, I began my tenure with a strong reminder that, for all systems, the quality of testing and information obtained from testing is a major concern to the Congress as well as to the Department of Defense. Events since September 11 have once again confirmed the importance of fielding effective and suitable weapon systems. There simply may not be enough time to “get it right” after a weapon system is provided to our soldiers, sailors, airmen, and marines.

I have committed to provide the Secretary of Defense and other senior decision makers in the Department with objective assessments, on a continuous and timely basis, of our weapon systems undergoing test and evaluation, and to work diligently to implement the recommendations of the December 2000 Defense Science Board (DSB) report on test and evaluation. In that context, I am committed to having the test and evaluation community focus its test programs on military missions, accomplishment of those missions, and total life-cycle suitability. Finally, I am committed to ensuring that reliable, effective, and safe weapons are delivered to our dedicated combat forces through robust testing.

As DOT&E, I will do everything in my power to address these concerns and keep these commitments. The guidance I have provided my staff, and shared with the Service Operational Test Agencies, is to strive to achieve the following objectives:

1. Rigorous, robust testing that is adequate by any standard, focused on military missions and mission accomplishment and total life-cycle suitability. One principal responsibility will be to provide timely and objective information on a system's demonstrated capability-to-date to decision makers, as opposed to judging only the overall effectiveness/suitability of a system in a pass/fail mode relative to some set of requirements at the end of the development. In order to accomplish this, we will need quality evaluation plans, complete and clear Test and Evaluation Master Plans (TEMPs), production representative systems for OT&E, and no waivers or deferrals to the completeness of evaluations.
2. A test infrastructure that can execute adequate testing in time to meet a program's reasonable schedule. “Testing takes too much time,” is often an excuse used to cut back on testing. The T&E infrastructure must be systematically improved to support reasonable schedules.
3. “Tell-it-like-it-is” reports that are complete, accurate, objective, and timely to support programmatic decisions, accomplished in a mission context as opposed to specification compliance.

### QUALITY OF TESTING

The December 2000 Defense Science Board Report noted, “The systems below Acquisition Category (ACAT) I in the priority system are being fielded without adequate testing. Even for the ACAT I programs there is growing evidence that testing is not being done adequately.” This is in line with

Senator Warner's concern with the quality of testing at all levels. I am, quite frankly, raising the bar on what will be considered adequate test and evaluation while, at the same time, striving to get systems that are effective and suitable into the hands of our forces faster. For the last two years, our Annual Reports have noted the problems of testing non-major systems (i.e., below ACAT I), which are not under OSD oversight. Reports from the Operational Test Agencies this year indicate little has changed since the DSB assessment of a year ago.

My initial efforts to increase the quality of testing have focused on ensuring that operational tests are complete enough to provide data adequate for the evaluation.

One feature of current practice I seek to change is the Service's ability to waive tests without DOT&E review and approval. The Defense Science Board strongly recommended that Secretary of the Navy Instruction 5000.2B be modified to rule out waivers as a unilateral action by the Service. The current policy allows waivers from criteria for certification of readiness for operational test (such as completion of the system safety program) and waivers for deviation from testing requirements directed by the Test and Evaluation Master Plan.

I have begun a dialogue with the Service to modify this regulation. The modification, I believe, should meet two objectives: first, to treat TEMP requirements as a contract between the Service and OSD that can be changed only by mutual consent, and second, to ensure that the decision maker, at whatever level, has the benefit of knowing that all important information, including waived parameters, was used in resolving critical operational issues.

A second area where effort is needed to improve the quality of testing is software testing. Reviews of Department testing have repeatedly criticized the quality of software testing. This year, in a continuing series of external reviews sponsored by my office and the Under Secretary of Defense for Acquisition, Technology and Logistics (USD(AT&L)), the National Academy of Science held a workshop on Software Reliability Testing. This workshop brought in experts from industry, academia, and defense to review how DoD does software development and testing. The National Academy concluded that the Department is not using the best test practices available. Practices such as use-based testing are known in industry to be faster in identifying problems and, therefore, to save cost and time. The consensus of the workshop participants was that the Department should be more proactive in using the methods that increase the tempo at which we gain information from testing. In cooperation with the USD(AT&L), we have begun to explore designating a number of pilot programs in this area.

Although I feel strongly that the quality of testing needs to improve, I also believe that we can get weapons that are effective and suitable into the hands of our forces faster by increasing the tempo of testing. In this area, we have worked with USD(AT&L) to accelerate the testing and fielding of systems that might be especially relevant to the campaign against global terrorism. We are evaluating a number of programs where testing could be accelerated, and where enough is already known to ensure that the system in its present state would increase our capability. None of this is business as usual. This type of accelerated test activity and up-to-the-minute evaluation will require greater flexibility from ranges and test organizations.

## **INFRASTRUCTURE: FACILITIES, PEOPLE, AND PROCESSES**

### **FACILITIES**

In the long run, increasing the tempo of testing will require a shift in our current practices for funding and managing test facilities and ranges. The current financial system has evolved away from the guidance provided when the Major Range and Test Facilities Base was established. At the present time, defense programs must bear both the cost of their tests and the overhead costs to maintain the ranges. This has proven to be a disincentive to testing. The cost to program managers has risen sharply over the past decade as they take on the overhead costs of the test ranges; as a result, program managers seek to minimize the amount (and therefore the cost) of testing. As they succeed, their success forces the price even higher for each test. Operational Testing sees the results of inadequate development testing at the end of the development phase. The one Service that has presented information on this to us indicates that more systems are failing to meet suitability requirements now than when we had a different kind of test funding. At present the reimbursable rate is about 75 percent for the Army, 63 percent for the Air Force, and 67 percent for the Navy. Unfortunately, these data have uncertainty associated with them that makes comparison difficult because there is no common financial management system among the Services.

After reviewing the Department's T&E capability, the Defense Science Board task force recommended in December 2001 that DoD create a DoD T&E Resource Enterprise under the Office of the Director of Operational Test and Evaluation to fund and manage the DoD T&E organizations, work force, and infrastructure.

On June 28, 2001, the Secretary of Defense noted in testimony on the 2002 Defense Department amended budget that, "We need to get on a path to correct the most serious deficiencies; we need to stabilize the force and begin modernization; we need to restore DoD infrastructure...." Our re-capitalization of the testing infrastructure technical facilities is on the order of 70 years. Commercial best practice is about 17 years. It would be a major task to create and defend the budgets needed to fix the infrastructure.

The SASC Report states "The committee directs the Department to develop a budget plan and schedule for the implementation of the Defense Science Board's recommendations, to be submitted along with the fiscal year 2003 budget request." Creating a DoD T&E Resource Enterprise, as recommended by the DSB, would be a major, controversial step. After review of plans to implement this proposal, the Department chose not to go forward with this recommendation in the FY03 budget.

### **PEOPLE**

Infrastructure is not limited to facilities, but also includes people and processes. The DSB Task Force "learned that the issue of human resources – how to attract and retain personnel with the motivation and skill to serve and lead in civilian and military capacities – is one of the most significant concerns of the T&E community."

The demographics of T&E show that a large fraction of its community will soon be eligible to retire. Further, the downsizing over the last ten years has all but precluded the recruiting of new talent. As a result, the relationships established by our T&E community over the years with universities and the hiring of graduates with skills in new research areas have suffered. We have begun to address this issue with a new effort called "Test and Evaluation/Science and Technology." This program element addresses two concerns: first, bringing leading edge technologies to the T&E business; and second, establishing links between the test ranges and universities where much of that research is done.

A second aspect of recruiting of new talent is the ability to offer a wage competitive with industries in these high technology areas. Pay-banding has proven to be an effective way to attract and keep (for some time) new graduate talent. Unfortunately, only a few Service test ranges have implemented this option. I would recommend modifications to the pay grade system to allow the pay-banding option in hiring for all the ranges.

## **PROCESSES**

A common financial management system is an essential first step to improved management of our nation's test ranges. The present set of individual range accounting systems, many of which do not meet current DoD accounting system standards, simply does not provide the type of information needed for efficient management.

## **REPORTING TEST RESULTS**

Congressional interest has, this year, resulted in legislation on communication of safety concerns from operational test and evaluation officials to program managers. The National Defense Authorization Act for Fiscal Year 2002, Section 263 states in part, "The Director shall ensure that safety concerns developed during the operational test and evaluation of a weapon system under a major defense acquisition program are communicated in a timely manner to the program manager for that program and for consideration in the acquisition decision making process." With respect to this congressional concern, I have issued the following policy:

- The responsible test organization shall, to the maximum extent practicable, release valid test data and factual information in as near real-time as possible to all parties with a need to know. Data may be preliminary and should be recognized as such.
- To protect the integrity of the OTA evaluation process, release of evaluation results may be withheld until the final report, according to each OTA's established policies.
- This policy is effective immediately and will be incorporated in the next revision of DoD Regulation 5000.2-R.

## **CONCLUSION**

We face many challenges in our commitment to improve the quality of testing, the infrastructure to support testing, and the reporting of test results. Ensuring that testing is rigorous and robust by any standard, providing an infrastructure that executes adequate testing in time to meet a program's schedule, and submitting "tell-it-like-it-is" reports are the necessary steps to bringing about those improvements. I am honored to have the opportunity to work toward these ends.

## MAJOR REPORTS

In FY01 through February 14, 2002, there have been 12 formal reports on the OT&E and LFT&E of weapons systems for submittal to Congress. These reports are bound separately and available on request. The reports are: Predator UAV OT&E, Minuteman III PRP, M2A3 Bradley Fighting Vehicle System OT&E/LFT&E, 2000 Pound JDAM OT&E, B-2 LFT&E, USS Osprey (MHC 51) Class Coastal Mine Hunter OT&E, MH-47E and MH-60K SOA LFT&E, AN/ALQ-135 Internal Countermeasure Set for the F-15E Strike Eagle OT&E, V-22 Osprey OT&E and LFT&E, XM1001 40mm Canister Cartridge LFT&E, Joint Primary Aircraft Training System OT&E, and Cooperative Engagement Capability OT&E.

This annual report responds to statutory requirements. No waivers were granted to subsection 2399 (e)(1), Title 10, United States Code, pursuant to subsection 2399 (e)(2). Members of my staff and I will be happy to provide additional information as appropriate.

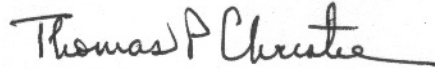

Thomas P. Christie  
Director

This Page Is Intentionally Left Blank

# TABLE OF CONTENTS

## PART I DOT&E ACTIVITY AND PROGRAM SUMMARY OVERSIGHT

DOT&E ACTIVITY SUMMARY.....	I-1
DOT&E PROGRAM OVERSIGHT.....	I-5

## PART II TEST RESOURCES AND RANGES

T&E RESOURCES: AN APPROACH TO TRANSFORM DoD'S T&E RESOURCES ....	II-1
--	------

## PART III ARMY PROGRAMS

ABRAMS TANK (M1A2).....	III-1
ADVANCED FIELD ARTILLERY TACTICAL DATA SYSTEM (AFATDS).....	III-5
AH-64D LONGBOW APACHE & LONGBOW HELLFIRE MISSILE.....	III-7
ALL SOURCE ANALYSIS SYSTEM (ASAS) .....	III-11
ARMY MULTIFUNCTION INFORMATION DISTRIBUTION SYSTEM	
LOW VOLUME TERMINAL 2 (MIDS-LVT 2) .....	III-13
ARMY TACTICAL MISSILE SYSTEM (ARMY TACMS)	
BLOCK II / BRILLIANT ANTI- ARMOR (BAT) .....	III-15
BATTLEFIELD COMBAT IDENTIFICATION SYSTEM (BCIS) .....	III-19
BRADLEY FIGHTING VEHICLE SYSTEM-A3 (BFVS-A3) .....	III-23
CH-47F IMPROVED CARGO HELICOPTER (ICH) .....	III-25
CHEMICAL DEMILITARIZATION PROGRAM .....	III-29
COMANCHE (RAH-66).....	III-33
CRUSADER HOWITZER AND RESUPPLY VEHICLE .....	III-37
FORCE XXI BATTLE COMMAND, BRIGADE AND BELOW (FBCB2).....	III-39
FORWARD AREA AIR DEFENSE COMMAND, CONTROL	
COMMUNICATIONS, AND INTELLIGENCE (FAAD C3I) SYSTEM .....	III-43
INTERIM ARMORED VEHICLE (IAV).....	III-47
JAVELIN ANTITANK MISSILE .....	III-51
JOINT COMPUTER-AIDED ACQUISITION AND LOGISTICS	
SUPPORT (JCALS) SYSTEM .....	III-53
JOINT LAND ATTACK CRUISE MISSILE DEFENSE (LACMD)	
ELEVATED NETTED SENSOR SYSTEM (JLENS) .....	III-55
JOINT SIMULATION SYSTEM (JSIMS).....	III-57
JOINT TACTICAL RADIO SYSTEM (JTRS) .....	III-59
LINE-OF-SIGHT ANTITANK MISSILE (LOSAT).....	III-61
M829E3 120-MM APFSDS-T CARTRIDGE .....	III-63
MANEUVER CONTROL SYSTEM (MCS).....	III-65
MULTIPLE LAUNCH ROCKET SYSTEM (MLRS) M270A1 LAUNCHER .....	III-67

PROPHET .....	III-69
RESERVE COMPONENT AUTOMATION SYSTEM (RCAS) .....	III-71
RQ-7 SHADOW 200 TACTICAL UNMANNED AERIAL VEHICLE (TUAV) SYSTEM.....	III-73
SECURE, MOBILE, ANTIJAM, RELIABLE, TACTICAL TERMINAL (SMART-T) .....	III-77
STINGER RMP MISSILE .....	III-79
SUITE OF INTEGRATED INFRARED COUNTERMEASURES AND COMMON MISSILE WARNING SYSTEM (CMWS, AN/AAR-57) (SIIRCM/CMWS) INCLUDES: ADVANCED THREAT INFRARED COUNTERMEASURES (ATIRCM, AN/ALQ-212) .....	III-81
SUITE OF INTEGRATED RADIO FREQUENCY COUNTERMEASURES (SIRFC) AN/ALQ-211 .....	III-85
TOW FIRE AND FORGET (TOW-F&F).....	III-87
TRANSPORTATION COORDINATORS' AUTOMATED INFORMATION FOR MOVEMENTS SYSTEM II (TC-AIMS II).....	III-89
UH-60M BLACK HAWK .....	III-91
WARFIGHTER INFORMATION NETWORK – TACTICAL (WIN-T).....	III-95
WIDE-AREA MUNITION (WAM) ADVANCED HORNET.....	III-97

#### **PART IV NAVY PROGRAMS**

ADVANCED AMPHIBIOUS ASSAULT VEHICLE (AAAV) .....	IV-1
ADVANCED COMBAT DIRECTION SYSTEM (ACDS) BLOCK I.....	IV-5
ADVANCED DEPLOYABLE SYSTEM (ADS).....	IV-7
ADVANCED INTEGRATED ELECTRONIC WARFARE SYSTEM (AIEWS) AN/SLY-2(V).....	IV-9
AIM-9X SIDEWINDER AIR-TO-AIR MISSILE .....	IV-11
AIRBORNE MINE COUNTERMEASURES RAPID AIRBORNE MINE CLEARANCE SYSTEM (RAMICS) AIRBORNE MINE NEUTRALIZATION SYSTEM (AMNS).....	IV-13
AMPHIBIOUS ASSAULT SHIP (REPLACEMENT) (LHA (R)).....	IV-17
AMPHIBIOUS TRANSPORT DOCK SHIP (LPD 17).....	IV-19
ARLEIGH BURKE (DDG 51) CLASS GUIDED MISSILE DESTROYER WITH THE AEGIS WEAPON SYSTEM, AN/SPY-1D/D(V) RADAR AND AN/SQQ-89(V) INTEGRATED SURFACE SHIP ANTI-SUBMARINE WARFARE COMBAT SYSTEM.....	IV-23
COOPERATIVE ENGAGEMENT CAPABILITY (CEC) .....	IV-27
CVN(X) FUTURE AIRCRAFT CARRIER .....	IV-31
DD(X) LAND ATTACK DESTROYER.....	IV-33
DEFENSE INTEGRATED MILITARY HUMAN RESOURCES SYSTEM (DIMHRS).....	IV-35
DRY CARGO/AMMUNITION SHIP (T-AKE 1).....	IV-37
E-2 AIRBORNE EARLY WARNING (AEW) HAWKEYE 2000 .....	IV-39
EA-6B UPGRADES.....	IV-43



EVOLVED SEA SPARROW MISSILE (ESSM).....	IV-47
EX-171 EXTENDED RANGE GUIDED MUNITION (ERGM).....	IV-51
F/A-18 E/F SUPER HORNET .....	IV-53
INTEGRATED DEFENSIVE ELECTRONIC COUNTERMEASURES (IDECM) AN/ALQ-214 .....	IV-57
JOINT MARITIME COMMAND AND CONTROL CAPABILITY (JCC(X)) SHIP .....	IV-61
JOINT MISSION PLANNING SYSTEM (JMPS).....	IV-63
JOINT STANDOFF WEAPON (JSOW) .....	IV-65
MH-60R MULTI-MISSION HELICOPTER UPGRADE.....	IV-69
MH-60S FLEET COMBAT SUPPORT HELICOPTER.....	IV-73
MISSILE AND LASER WARNING SYSTEM, AN/AAR-47(V)2.....	IV-77
MK 48 ADCAP TORPEDO UPGRADES .....	IV-79
MULTIFUNCTION INFORMATION DISTRIBUTION SYSTEM - LOW VOLUME TERMINAL 1 (MIDS-LVT 1) .....	IV-81
NAVY EXTRA HIGH FREQUENCY SATELLITE COMMUNICATIONS PROGRAM (NESP).....	IV-83
NAVY MARINE CORPS INTRANET (NMCI).....	IV-85
NAVY STANDARD INTEGRATED PERSONNEL SYSTEM (NSIPS).....	IV-87
RADAR WARNING RECEIVER (RWR) AN/APR-39A (V)2.....	IV-89
ROLLING AIRFRAME MISSILE (RAM) WEAPON SYSTEM.....	IV-91
RQ-8A FIRESOULT VERTICAL TAKEOFF AND LANDING TACTICAL UNMANNED AERIAL VEHICLE SYSTEM (VTUAV).....	IV-95
SEAWOLF SSN 21 CLASS ATTACK SUBMARINE AND AN/BSY-2 COMBAT SYSTEM.....	IV-99
SHIP SELF DEFENSE SYSTEM (SSDS) .....	IV-103
STANDARD MISSILE-2 (SM-2).....	IV-105
STANDOFF LAND-ATTACK MISSILE EXPANDED RESPONSE (SLAM ER).....	IV-107
STRATEGIC SEALIFT PROGRAM (SSP).....	IV-109
SUBMARINE EXTERIOR COMMUNICATIONS SYSTEM (SubECS).....	IV-111
TACTICAL AIRCRAFT MISSION PLANNING SYSTEM (TAMPS).....	IV-113
TOMAHAWK.....	IV-115
USMC H-1 UPGRADES .....	IV-117
V-22 OSPREY .....	IV-119
VIRGINIA (SSN 774) CLASS ATTACK SUBMARINE.....	IV-123

## **PART V AIR FORCE PROGRAMS**

ADVANCED EXTREMELY HIGH FREQUENCY (AEHF) SATELLITE COMMUNICATIONS SYSTEM .....	V-1
AIM-120 AMRAAM.....	V-3
AIR FORCE MISSION SUPPORT SYSTEM (AFMSS).....	V-5
AIRBORNE LASER (ABL) .....	V-7
B-1B CONVENTIONAL MISSION UPGRADE PROGRAM (CMUP).....	V-11
B-2 SPIRIT .....	V-15

C-130 AIRCRAFT MODERNIZATION PROGRAM (AMP).....	V-21
C-130J AIRLIFT AIRCRAFT .....	V-23
C-17 GLOBEMASTER III AIRLIFT AIRCRAFT .....	V-27
C-5 RELIABILITY ENHANCEMENT AND RE-ENGINEERING PROGRAM (RERP).....	V-31
COMBAT SURVIVOR EVADER LOCATOR (CSEL) SYSTEM .....	V-33
DEFENSE CIVILIAN PERSONNEL DATA SYSTEM (DCPDS) .....	V-37
E-3 AIRBORNE WARNING AND CONTROL SYSTEM (AWACS).....	V-39
EVOLVED EXPENDABLE LAUNCH VEHICLE (EELV) .....	V-41
F-15 FIGHTER DATA LINK (FDL).....	V-43
F-15 TACTICAL ELECTRONIC WARFARE SYSTEM (TEWS) (AN/ALQ-135 BAND 1.5) .....	V-45
F-22 RAPTOR (ATF).....	V-49
GLOBAL BROADCAST SERVICE (GBS).....	V-55
JOINT AIR-TO-SURFACE STANDOFF MISSILE (JASSM).....	V-57
JOINT DIRECT ATTACK MUNITION (JDAM).....	V-61
JOINT HELMET MOUNTED CUEING SYSTEM (JHMCS) .....	V-63
JOINT PRIMARY AIRCRAFT TRAINING SYSTEM (JPATS).....	V-65
JOINT STRIKE FIGHTER (JSF) .....	V-69
JOINT SURVEILLANCE TARGET ATTACK RADAR SYSTEM (JSTARS) E-8C AND COMMON GROUND STATION (CGS), MULIT-PLATFORM RADAR TECHNOLOGY INSERTION PROGRAM (MP-RTIP), MULTI-PLATFORM COMMON DATA LINK (MP-CDL).....	V-73
LARGE AIRCRAFT INFRARED COUNTERMEASURES (LAIRCM).....	V-77
MILSTAR SATELLITE SYSTEM.....	V-79
MINUTEMAN III GUIDANCE AND PROPULSION REPLACEMENT PROGRAMS .....	V-83
NATIONAL AIRSPACE SYSTEM (NAS).....	V-85
NATIONAL POLAR-ORBITING OPERATIONAL ENVIRONMENTAL SATELLITE SYSTEM (NPOESS).....	V-89
NAVSTAR GLOBAL POSITIONING SYSTEM (GPS).....	V-93
RADAR WARNING RECEIVER (RWR) AN/ALR-56M.....	V-97
RQ-1A PREDATOR UNMANNED AERIAL VEHICLE (UAV) SYSTEM.....	V-99
RQ-4A GLOBAL HAWK UNMANNED AERIAL VEHICLE (UAV) SYSTEMS .....	V-103
SENSOR FUZED WEAPON (SFW).....	V-107
SPACE-BASED INFRARED SYSTEM (SBIRS).....	V-111
TRANSCOM REGULATING AND COMMAND & CONTROL EVACUATION SYSTEM (TRAC <sup>2</sup> ES) .....	V-115
WIDEBAND GAFILLER SATELLITE (WGS) .....	V-117

## **PART VI OTHER DEFENSE PROGRAMS**

### ***BMDO***

MEDIUM EXTENDED AIR DEFENSE SYSTEM (MEADS) .....	VI-1
NATIONAL MISSILE DEFENSE (NMD (GROUND-BASED MIDCOURSE DEFENSE).....	VI-3
NAVY AREA THEATER BALLISTIC MISSILE DEFENSE (NATBMD).....	VI-9
NAVY THEATER WIDE / SEA BASED MID-COURSE (NTW/SBMC) .....	VI-13
PATRIOT ADVANCED CAPABILITY-3 (PAC-3).....	VI-17
THEATER HIGH ALTITUDE AREA DEFENSE (THAAD).....	VI-21

### ***DFAS***

DEFENSE JOINT ACCOUNTING SYSTEM (DJAS).....	VI-25
DEFENSE PROCUREMENT PAYMENT SYSTEM (DPSS) .....	VI-27

### ***DISA***

DEFENSE MESSAGE SYSTEM (DMS).....	VI-29
-----------------------------------	-------

### ***DLA***

BUSINESS SYSTEMS MODERNIZATION (BSM).....	VI-31
FUELS AUTOMATED SYSTEM (FAS).....	VI-33
STANDARD PROCUREMENT SYSTEM (SPS) .....	VI-35

### ***DoD***

JOINT BIOLOGICAL POINT DETECTION SYSTEM (JBPDS) .....	VI-37
JOINT CHEMICAL AGENT DETECTOR (JCAD).....	VI-41
JOINT SERVICES LIGHT NUCLEAR, BIOLOGICAL, AND CHEMICAL RECONNAISSANCE SYSTEM (JSLNBCRS) .....	VI-43
JOINT SERVICES LIGHTWEIGHT STANDOFF CHEMICAL AGENT DETECTOR (JSLSCAD) .....	VI-47
JOINT WARNING AND REPORTING NETWORK (JWARN).....	VI-49

### ***HEALTH AFFAIRS***

COMPOSITE HEALTH CARE SYSTEM II (CHCS II).....	VI-53
DEFENSE MEDICAL LOGISTICS STANDARD SUPPORT AUTOMATED INFORMATION SYSTEM (DMLSS AIS).....	VI-55
THEATER MEDICAL INFORMATION PROGRAM (TMIP).....	VI-57

**PART VII JOINT TEST AND EVALUATION (JT&E)**

INTRODUCTION – JOINT TEST AND EVALUATION (JT&E) ..... VII-1  
JOINT BATTLE DAMAGE ASSESSMENT (JBDA)..... VII-5  
JOINT CLOSE AIR SUPPORT (JCAS)..... VII-7  
JOINT COMMAND AND CONTROL, INTELLIGENCE, SURVEILLANCE  
AND RECONNAISSANCE (JC2ISR) ..... VII-9  
JOINT CRUISE MISSILE DEFENSE (JCMD) ..... VII-11  
JOINT GLOBAL POSITIONING SYSTEM COMBAT  
EFFECTIVENESS (JGPSCE) ..... VII-13  
JOINT SHIPBOARD HELICOPTER INTEGRATION PROCESS (JSHIP)..... VII-15  
JOINT SUPPRESSION OF ENEMY AIR DEFENSES (JSEAD) ..... VII-19  
JOINT THEATER DISTRIBUTION (JTD) ..... VII-21  
JOINT WARFIGHTERS (JWF) ..... VII-23

**PART VIII NON-MAJOR SYSTEMS OT&E**

NON-MAJOR SYSTEMS OT&E..... VIII-1

**PART IX LIVE FIRE TEST AND EVALUATION (LFT&E)**

LIVE FIRE OVERVIEW ..... IX-1

**INDEX OF PROGRAMS**

# **PART I**

## **DOT&E ACTIVITY SUMMARY AND PROGRAM OVERSIGHT**



## DOT&E ACTIVITY SUMMARY

DOT&E activity for FY01 involved oversight of 219 programs, including 18 major automated information systems. Oversight activity begins with the early acquisition milestones, continues through approval for full-rate production and, in some instances, during full production until deleted from the DOT&E oversight list.

Our review of test planning activities for FY01 included approval of 44 Test and Evaluation Master Plans (TEMPs), as well as 50 Operational Test Plans. Live Fire Test and Evaluation (LFT&E) activity included the approval of 14 LFT&E Strategies and Test Plans for inclusion in the TEMPs. In FY01 through February 14, 2002, DOT&E prepared 12 reports for the Secretary of Defense and the Congress.

DOT&E also prepared and submitted numerous reports to DAB principals for consideration in DAB deliberations.

### TEST AND EVALUATION MASTER PLANS APPROVED

Aberdeen Chemical Disposal Facility Program	Chemical Demilitarization Program Umatilla	M1A2 Abrams Tank
Advanced Amphibious Assault Vehicle (AAAV)	Chemical Agent Disposal Facility	MILSTAR II Satellite Communications System
Advanced Combat Direction System (ACDS) Block I	Cooperative Engagement Capability (CEC)	Minuteman III Propulsion Replacement Program (PRP)
Advanced Extremely High Frequency Satellite Communications System	F/A-18 Positive Identification System (PIDS)	Multifunctional Information Distribution System (MIDS) - Low Volume Terminal (LVT) F-16 Integration
Advanced Field Artillery Tactical Data System (AFATDS) 99 LUTE	F/A-18E/F Active Electronically Scanned Array (AES) Radar	Multifunctional Information Distribution System (MIDS) - Low Volume Terminal (LVT) Shipboard Integration
Army UH-60M Black Hawk Utility Helicopter	F/A-18E/F Software Qualification Test (SQT) and FOT&E	Navy Extremely High Frequency (EHF) Satellite Communications (SATCOM) Program (NESP)
Auxillary Cargo and Ammunition Ship (T-AKE)	F-22	Navy Standard Integration Personnel System (NSIPS)
B-1B CMUP Block E Computer Upgrade and Wind Corrected Munitions Dispenser (WCMD) Integration Program	Fuels Automated System (FAS)	PROPHET Ground Block I (PGB1)
Business Systems Modernization (BSM)	Interim Armored Vehicle (IAV)	Reserve Component Automation System (RCAS)
C-130X Phase I Avionics Modernization Program (AMP)	Joint Direct Attack Munition (JDAM) Program Milestone III	Reserve Component Automation System (RCAS) Increment 6
Chemical Demilitarization Program Newport	Joint Helmet-Mounted Cueing System (JHMCS)	
Chemical Agent Disposal Facility	Joint Service Light Nuclear, Biological, and Chemical Reconnaissance System (JSLNBRCS)	
	Large Aircraft Infrared Countermeasure (LAIRCM)	

RQ-4A Global Hawk  
 Unmanned Aerial Vehicle  
 SEAWOLF (SSN-21)  
 Suite of Integrated Infrared  
 Countermeasures  
 (SIIRCM) Program  
 Tactical Automated Mission  
 Planning System (TAMPS)  
 Theater Medical Information  
 Program (TMIP)

TOMAHAWK Command  
 and Control System (TC2S)  
 TOMAHAWK Cruise  
 Missile  
 Transportation Command  
 (TRANSCOM) Regulating  
 and Command & Control  
 Evacuation System  
 (TRAC<sup>2</sup>ES)

V-22 Osprey Change One  
 VIRGINIA (SSN 774)  
 Wideband Gapfiller (WGS)

### OPERATIONAL TEST PLANS APPROVED

Advanced Amphibious  
 Assault Vehicle (AAAV)  
 EOA  
 Advanced Amphibious  
 Assault Vehicle (AAAV)  
 Ballistic Hull and Turret  
 DTP  
 Advanced Combat Direction  
 System (ACDS) Block I  
 OT-III E  
 Advanced TOMAHAWK  
 Weapon Control System  
 (ATWCS) OT-III L  
 ALR-56/ALE-47 FOT&E  
 AN/APR-39A(V) Radar  
 Warning Detecting Set  
 OT-III A  
 AN/APR-39A(V) Radar  
 Warning Detecting Set  
 OT-III B  
 AN/USQ-113 (V)3 Radio  
 Countermeasures Set  
 OT-III C/D  
 Army Tactical Unmanned  
 Aerial Vehicle (TUAV)  
 EDP  
 Battlefield Combat  
 Identification System EDP  
 Bradley Fighting Vehicle  
 System IOT&E EDP  
 Brilliant Anti-armor  
 Submunition (BAT)  
 DTP/EDP

CH-47 Chinook Aircraft  
 Engine Nacelle Fire  
 Suppression System  
 Combat Survivor Evader  
 Locator (CSEL) OA2 OTP  
 Cooperative Engagement  
 Capability (CEC) OT-III A4  
 Defense Civilian Personnel  
 Data System (DCPDS)  
 E-2C Hawkeye Mission  
 Computer Upgrade (MCU)  
 Evolved Sea Sparrow Missile  
 (ESSM) OT-III B  
 Evolved Sea Sparrow Missile  
 (ESSM) OT-III C  
 F/A-18E/F OT-III A  
 F-22 SAMP  
 Force XXI Battle Command,  
 Brigade and Below  
 (FBCB2) EDP  
 Fuel Automated Systems  
 (FAS) (Bulk Fuels)  
 Joint Air-to-Surface Strike  
 Missile (JASSM) DT-5  
 Joint Biological Point  
 Detection System OA2  
 Joint Helmet-Mounted  
 Cueing System (JHMCS)  
 Joint Surveillance Target  
 Attack Radar System  
 (JSTARS) Common  
 Ground Station (CGS)  
 Version 2 OA ATEC EDP

M1A2 System Enhancement  
 Program (SEP) EDP  
 M270A1 Multiple Launch  
 Rocket System (MLRS)  
 Medium Armored Vehicle  
 (MAV) CEP  
 Multifunctional Information  
 Distribution System  
 (MIDS) - Low Volume  
 Terminal (LVT) OT-III A-3I  
 (F/A-18C/D)  
 Multifunctional Information  
 Distribution System  
 (MIDS) - Low Volume  
 Terminal (LVT) Shipboard  
 Integration OT-III B-I  
 Multifunctional Information  
 Distribution System  
 (MIDS) - Low Volume  
 Terminal (LVT) Shipboard  
 Integration  
 Navy Extremely High  
 Frequency (EHF) Satellite  
 Communications  
 (SATCOM) Program  
 (NESP) Terminal OT-III C  
 Navy Standard Integration  
 Personnel System (NSIPS)  
 OT-III B  
 PROPHET Ground 1 (PGB1)  
 SEP  
 Reserve Component  
 Automation System  
 (RCAS) Increment 4/5 SEP



Reserve Component Automation System (RCAS) Increment 6 SEP/EDP	Suite of Integrated Radio Frequency Countermeasures (SIRFC)	USS SEAWOLF (SSN 21) and AN/BSY-2 (V) Submarine Combat System Minefield OTP
Sensor Fuzed Weapon (SFW) P3I OT&E Support Plan	Tactical Automated Mission Planning System (TAMPS) OT-IIIH	USS SEAWOLF (SSN 21) and AN/BSY-2(V) Submarine Combat System
Standoff Land Attack Missile-Expanded Response (SLAM-ER)	Tomahawk Command and Control System (TC2S) OT-IIIH	Submarine Combat System Cold Water Test Plan
Strategic Sealift Program (SSP) OT-IIB	Unmanned Aerial Vehicle (UAV) Joint Tactical Control System (TCS)	USS SEAWOLF (SSN 21) and AN/BSY-2(V) Submarine Combat System Warm Water Test Plan
Submarine Communications Support System (SCSS)	USS SEAWOLF (SSN 21) and AN/BSY-2(V) Submarine Combat System	

**LFT&E STRATEGIES AND TEST PLANS APPROVED**

Auxillary Cargo and Ammunition Ship (T-AKE) LFT&E Plan	F-22 Wing Hydrodynamic Ram LFT Plan	M1A2 Abrams Tank Phase 3 EDP
C-130 Avionics Modernization Program (AMP) Alt LFT	Joint Air-to-Surface Strike Missile (JASSM) DT-4 LFT&E Plan	M1A2 LFT&E Phase 3 EDP/DTP
CH-47 Chinook (Improved Cargo Helicopter) Aircraft Propulsion System LFT Phase IV	Joint Air-to-Surface Strike Missile (JASSM) LFT&E Plan	Sensor Fuzed Weapon (SFW) P3I Live Fire Phase I Test Plan
DDG 81 Full Ship Shock Trial Plan (FSSTP)	Joint Strike Fighter (JSF) LFT&E Alt Plan	Sensor Fuzed Weapon (SFW) Pre-Planned Product Improvement LFT&E Plan
	M1A2 Abrams Tank Phase 3 DTP LFT Plan	

**REPORTS TO CONGRESS FOR FY01 TROUGH FEBRUARY 14, 2002**

F-15E TEWS AN/ALQ 135 Band 1.5 OT&E Report (November 2000)	B-2 Bomber Conventional Warfare Mission LFT&E Report (January 2001)	Predator Medium Altitude Endurance Unmanned Aerial Vehicle OT&E Report (September 2001)
V-22 Osprey OT&E/LFT&E Report (November 2000)	Joint Direct Attack Munition (JDAM) OT&E Report (March 2001)	Joint Primary Aircraft Training System (JPATS) OT&E Report (November 2001)
XM1001 40mm Canister Cartridge LFT&E Report (November 2000)	M2A3 Bradley Fighting Vehicle System (BFVS) OT&E/LFT&E Report (April 2001)	Cooperative Engagement Capability (CEC) OT&E Report (February 2002)
Coastal Mine Hunter (MHC 51) OT&E Report (December 2000)	Minuteman III Intercontinental Ballistic Missile (ICBM) Propulsion Replacement Program (PRP) OT&E Report (September 2001)	
MH-47E AND MH-60K SOA LFT&E Report (December 2000)		

During this fiscal year, DOT&E met with Service operational test agencies, program officials, private-sector organizations, and academia; monitored test activities; and provided information to the DAB committees as well as the DAB principals, the Secretary and Deputy Secretary of Defense, the USD(AT&L), the Service Secretaries, and the Congress. Active on-site participation in and observation of tests and test-related activities remain the most effective tools. In addition to on-site participation and local travel within the national capital region, approximately 680 trips supported the DOT&E mission.

Security considerations preclude identifying classified programs in this report. The objective, however, is to ensure operational effectiveness and suitability do not suffer due to extraordinary security constraints imposed on those programs.

## DOT&E PROGRAM OVERSIGHT

This office is responsible for approving the adequacy of plans for operational test and evaluation and for reporting the operational test results for all major defense acquisition programs to the Secretary of Defense, USD(AT&L), Service Secretaries, and the Congress. For DOT&E oversight purposes, major defense acquisition programs were defined in the law to mean those programs meeting the criteria for reporting under section 2430, title 10, United States Code (Selected Acquisition Reports (SARs)). The law (sec.139(a)(2)(B)) also stipulates that DOT&E may designate any other programs for the purpose of his oversight, review, and reporting. With the addition of such "non-major" programs, DOT&E was responsible for oversight of 219 acquisition programs during FY01.

Non-major programs are selected for DOT&E oversight after careful consideration of the relative importance of the individual program. In selecting non-SAR systems for oversight, consideration is given to one or more of the following essential elements:

- Congress or OSD agencies have expressed a high level of interest in the program.
- Congress has directed that DOT&E assess or report on the program as a condition for progress or production.
- The program requires joint or multi-Service testing (the law (sec. 139(b)(4)) requires the DOT&E to coordinate "testing conducted jointly by more than one military department or defense agency").
- The program exceeds or has the potential to exceed the dollar threshold definition of a major program according to DoD 5000.1, but does not appear on the current SAR list (e.g., highly classified systems).
- The program has a close relationship to or is a key component of a major program.
- The program is an existing system undergoing major modification.
- The program was previously a SAR program and OT is not yet complete.

This office is also responsible for the oversight of LFT&E programs, in accordance with 10 USC 139. DoD regulation uses the term "covered system" to include all categories of systems or programs identified in 10 USC 2366 as requiring live fire test and evaluation. In addition, systems or programs that do not have acquisition points referenced in 10 USC 2366, but otherwise meet the statutory criteria, are considered "covered systems" for the purpose of DOT&E oversight.

A covered system, for the purpose of oversight for LFT&E, has been determined by DOT&E to meet one or more of the following criteria:

- A major system within the meaning of that term in 10 USC 2302(5) that is:
  - user-occupied and designed to provide some degree of protection to the system or its occupants in combat.
  - a conventional munitions program or missile program.

- A conventional munitions program for which more than 1,000,000 rounds are planned to be acquired.
- A modification to a covered system that is likely to affect significantly the survivability or lethality of such a system.

The DOT&E was responsible for the oversight of 96 LFT&E acquisition programs during FY01.

**PROGRAMS UNDER DOT&E OVERSIGHT  
FISCAL YEAR 2001  
(As taken from the May 2001 Official T&E Oversight List)**

**ARMY**

ABRAMS UPGRADE (M1A2)	LONGBOW APACHE (AH-64D)	APR-39 (V)2
AERIAL COMMON SENSOR	LONGBOW HELLFIRE	ARCI
AFATDS (ATCCS)	LOSAT	ASDS
AN/TPQ-47 COUNTERFIRE RADAR	M1 BREACHER	AV-8B REMANUFACTURE
AQIS – BATTLEFIELD DIGITIZATION	M1 HAB	CCDS
ASAS (ATCCS)	M829E3 (120MM ROUND)	CEC
ATACMS BLOCK II BAT/BAT P3I	MCS (ATCCS)	CHCS II
BCIS	MLRS (GUIDED ROCKET)	CRUISER CONVERSION
BLACKHAWK (UH-60M)	MLRS UPGRADE (LAUNCHER)	CVN (X)
BRADLEY UPGRADE	NBC RECON VEHICLE	CVN 77 WARFARE SYSTEM
CEIS	OCSWS	CVN-68 CLASS
CGS	OICWS	DD 21
CH-47F HELICOPTER UPGRADE	PROPHET	DDG-51
CHEMICAL DEMILITARIZATION	RCAS	DIMHRS
COMANCHE (RAH-66)	SADARM	E-2C REPRODUCTION
CRUSADER	SCAMP	EA-6B
CSSCS (ATCCS)	SIIRCM/CMWS (ATIRCM/CMWS)	ERGM
DMLSS	SIRFC	ESSM
EXCALIBUR (155MM ROUND)	SMART-T	F/A-18 C/D
FAADS C2I (ATCCS)	STINGER-RMP	F/A-18 E/F
FBCB2	TC-AIMS II	IDECM
FMTV	TOW-FIRE & FORGET	IT-21
FUTURE COMBAT SYSTEMS	TUAV	JCC(X)
FUTURE SCOUT/CALVARY SYSTEM	WIDE AREA MUNITION P3I	JMPS
HIMARS	WIN-T	JSOW BASELINE
IAV	XM 96 LFHG	JSOW BLU-108
JAVELIN		JSOW UNITARY
JCALs	<b><u>NAVY</u></b>	KC-130 J AIRCRAFT
JLENS	AAAV	LHA (R)
JTRS	ACDS BLOCK I	LHD CLASS
KIOWA WARRIOR (OH-58D)	ADS/FDS	LPD-17
LAND WARRIOR	AEW	MARITIME PREPOSITIONING FORCE (FUTURE)
	AIEWS	MH60 HELICOPTER
	AIM-9X	MHC 51
	ALAM	MIDS - LVT
	ALR-67	MK-48 MODS ADCAP
	AMNS/RAMICS	MMA
	AN/AAR-47 UPGRADE	MUOS
	AN/SPY-1 B/D	NESP
	AN/SQQ-89	NMCI
	(SQS-53 SQR-19)	NSIPS
		QRCC/SSDS

RAM  
SEA SPARROW  
  AIM/RIM-7  
SH60R  
SLAM-ER  
SM-2 (BLKS III/IIIA&B)  
SM-2 BLK IV  
SSGN/TRIDENT  
  CONVERSION  
SSN-21 / AN/BSY-2  
SSN-23 JIMMY CARTER  
SSN-774 VIRGINIA CLASS  
STRATEGIC SEALIFT  
SUBECS  
T-45TS  
TACTICAL TOMAHAWK  
TACTICAL TOMAHAWK  
  MPS/TCCS  
T-AGOS/SURTASS/LFA  
T-AKE-1 (ADC (X))  
TAMPS  
TCS  
TMIP  
TRIDENT II MISSILE  
UHF FOLLOW-ON  
  SATELLITE  
USMC H1 UPGRADE  
V-22 OSPREY  
VERTICAL LAUNCH  
  ASROC  
VTUAV

#### **AIR FORCE**

A-10 UPGRADES  
ABL  
ADVANCED EHF  
ADVANCED WIDE BAND  
  SYSTEM  
AFMSS  
ALR-56M  
ALR-69  
AMRAAM (AIM-120)  
B-1B CMUP  
  ALL UPGRADES  
B-1B CMUP  
  COMPUTER UPGRADE

B-1B CMUP/DSUP  
B-2A  
C-130 AMP  
C-130J ALL VARIANTS  
C-17A/C-17A UPGRADES  
C-5 AMP  
C-5 RERP  
CDL  
CSAR  
CSEL  
DCGS  
DCPDS  
DMSP  
E-3A AWACS  
EELV  
F-15 TEWS  
F-22  
GBS  
GLOBAL HAWK UAV  
GTN  
ILS-S  
IMDS  
JASSM  
JDAM  
JDAM 500 LB  
JHMCS  
JPALS  
JPATS  
JSF  
JSTARS (E-8C)  
LAIRCM  
MILSTAR  
MINIATURIZED  
  MUNITIONS  
  CAPABILITY  
MINUTEMAN III GRP  
  PHASE I  
MINUTEMAN III PRP  
MP-RTIP  
NAS  
NAVSTAR GPS  
NPOESS  
PREDATOR  
SBIRS  
SFW P3I  
TBMCS  
TITAN IV

TRAC<sup>2</sup>ES  
WIDEBAND GAPFILLER

#### **BMDO**

MEADS  
NAVY AREA TBMD  
NMD  
NTW  
PATRIOT PAC-3 MISSILE  
SPACE BASED LASER  
THAAD/GBR

#### **DCMA**

SPS

#### **DFAS**

DCD/DCW  
DJAS  
DPPS

#### **DISA**

DMS  
GCCS (CAPSTONE)  
GCCS/GCSS

#### **DLA**

BSM  
FAS

#### **DOD**

CID  
JBPDS  
JBREWS  
JBSDS  
JCAD  
JSIMS  
JSLNBCRS  
JSLSCAD  
JWARN

**PART II**  
**TEST RESOURCES**  
**AND RANGES**





# **T&E RESOURCES:**

## **AN APPROACH TO TRANSFORM DoD'S T&E RESOURCES**

### **INTRODUCTION**

In this, my first annual report on the DoD test and evaluation (T&E) resources, I have two objectives: First, report on the “health” of T&E resources (people, facilities, and funding that support our test and evaluation programs), and second, describe my plans for measures to address the needs in these areas. I will also address my promise to the Secretary of Defense to work diligently to implement recent recommendations of the Defense Science Board (DSB) on T&E.<sup>1</sup> I am working to ensure that a test infrastructure is in place which is capable of adequate testing to meet the schedules of acquisition programs.

### **MOST TESTING OCCURS AT DOD'S MAJOR TEST RANGES AND CENTERS**

The majority of the developmental tests and some operational tests are conducted at the Major Range and Test Facility Base (MRTFB) locations shown in Figure 1. These sites contain the major, high-value test facilities within DoD and include significant air, land, and sea operating areas necessary to test modern weapon systems. The sites comprising the MRTFB are operated by 30,000 military, government civilian, and contractor personnel and consist of test facilities ranging from large wind tunnels and electronics integration test facilities to extensive open-air ranges. The book value of the MRTFB is over \$25 billion and it includes over half of all land owned or used by DoD.

The policy governing the MRTFB has remained unchanged since its founding in 1974: “The MRTFB is a national asset that shall be sized, operated, and maintained primarily for DoD T&E support missions.”<sup>2</sup> The intent of this policy is to ensure the MRTFB provides efficient, effective T&E capability with sufficient capacity margin to accommodate the fluctuations in test workload that are an inescapable feature of weapon system acquisition.

There are questions about the test infrastructure's ability to satisfactorily meet current and future T&E requirements in a manner that contributes to efficient weapon system acquisition. I am concerned that test resource issues may be one of the main reasons why adequate testing is not conducted in time to support deliberations associated with program decisions. Of particular concern are the following issues.

### **DoD SYSTEMS ARE NOT ADEQUATELY TESTED**

During the past decade while T&E infrastructure resources were being reduced, we witnessed an alarming trend of too many programs entering dedicated operational T&E (OT&E) without having completed sufficient developmental T&E (DT&E). As a result, the Services have conducted OT&E on immature systems and the results reflect the consequences. In recent years, 66 percent of Air Force programs have stopped operational testing due to a major system or safety shortcoming. Since 1996, approximately 80 percent of Army systems tested failed to achieve reliability requirements during operational testing.

---

<sup>1</sup> Report of the Defense Science Board Task Force on Test and Evaluation Capabilities, December 2000.

<sup>2</sup> DoD Directive 3200.11, *Major Range and Test Facility Base (MRTFB)*, January 26, 1998.

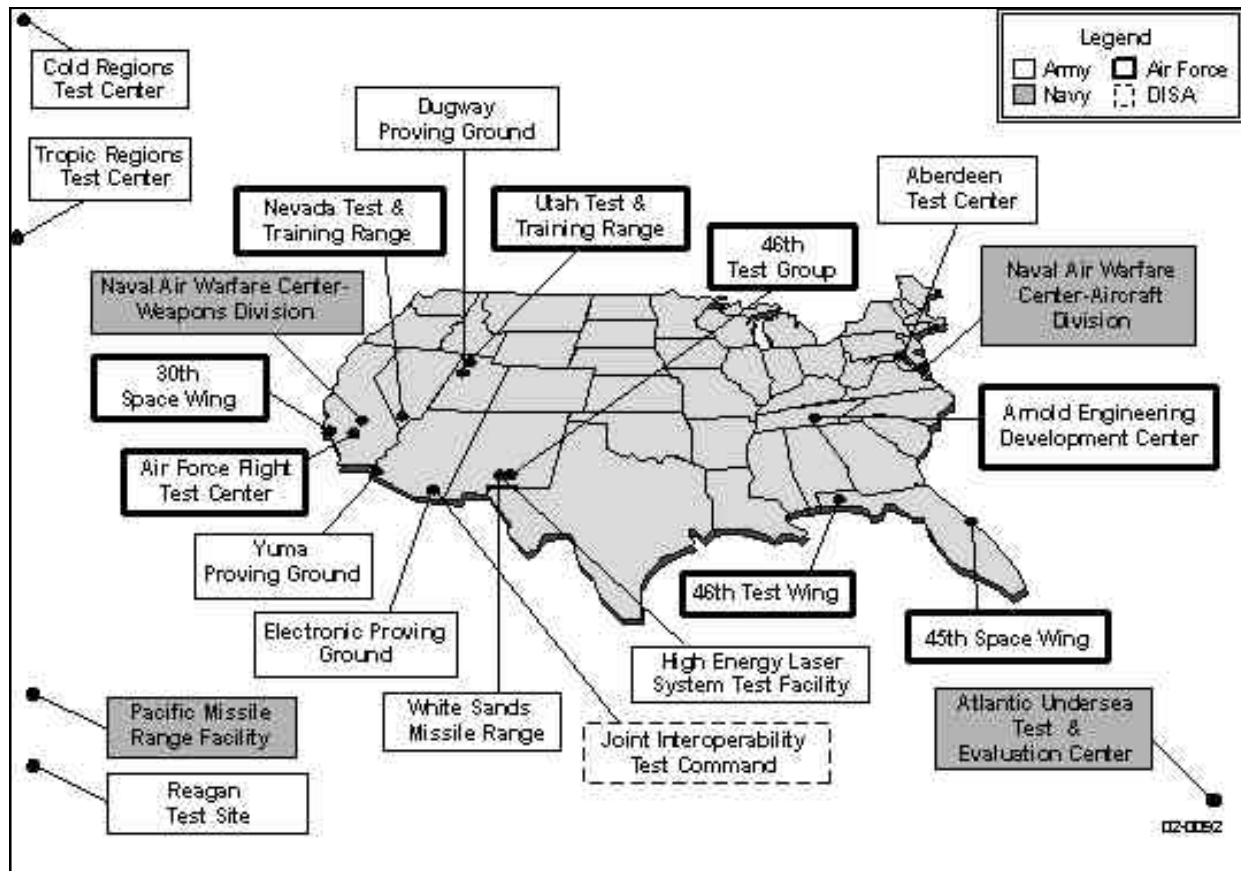

Figure 1. The Major Range and Test Facility Base

In its December 2000 report, the DSB Task Force on Test and Evaluation Capabilities found that weapon systems are not adequately tested to assure their effectiveness and utility to operating units. The acquisition process fails to deliver systems to the warfighter that meet reliability and effectiveness requirements. And, unlike the commercial marketplace where managers place value on product testing, DoD program managers view it as an impediment.

The T&E process is not adequately funded. Limited budgets and acquisition reform have forced program managers to curtail test programs. Underfunded test centers are shifting more and more of their testing costs to acquisition programs. This practice leads to further limits on testing and encourages waivers of test requirements. The increasing number of test waivers undermines test adequacy and contributes to a false sense of system developmental maturity. T&E personnel ordinarily are not involved in early acquisition program budget deliberations. Consequently, program test budgets are too often firmly established before test programs are defined.

#### LIMITED TEST RESOURCES CONTRIBUTE TO INADEQUATE TESTING

Infrastructure deficiencies contribute to inadequate testing by limiting the scope and depth of the testing that is conducted. An important step in carrying out my plan for improving our test infrastructure will be to identify such limiting deficiencies and prioritize measures to resolve them. My objectives are:

- **Reestablish a modern, effective test infrastructure.** Many facilities are aged and test capabilities for new technologies cannot be acquired due to insufficient investment. I will

define and advocate a program to recapitalize the test infrastructure so that future technologies can be adequately tested.

- **Redefine policy and funding to improve test effectiveness.** Under existing policy, a growing proportion of test costs are passed to the users (in most instances, the acquisition programs). Too often this leads to less testing. I will work to redefine charge policy and provide necessary funding to encourage users to plan and conduct adequate testing.

The remainder of this section discusses these issues and my plan for addressing them.

## **REESTABLISH MODERN, EFFECTIVE TEST INFRASTRUCTURE**

Testing must be rigorous, robust, and focused on military missions, mission accomplishment, and total life-cycle suitability. To ensure thorough testing, DoD's T&E infrastructure must be restored and transformed along with our weapon systems. DoD must take management policy and resource actions to ensure rigorous and robust testing as well as timely, objective, continuous assessments of weapon systems. Appropriate actions taken now can assure adequate testing of future DoD systems by renewing aging infrastructure, investing for new technologies, and improving management processes.

### **AGING TEST INFRASTRUCTURE MUST BE RENEWED**

The entire defense infrastructure has been underfunded for years and the T&E infrastructure is no exception. The recapitalization rate is based upon the value of the infrastructure and the annual resources provided to replace, upgrade, and maintain it. The facilities replacement rate for all DoD is approximately 192 years while the private sector replaces or modernizes its similar facilities at an average rate of once every 57 years.<sup>3</sup> Secretary Rumsfeld's goal is to reduce the DoD infrastructure recapitalization rate to 67 years as shown in Figure 2.

While the recapitalization rate for the entire T&E infrastructure is 400 years, the key elements of that infrastructure are the technical facilities and equipment that are actually used to support testing. This T&E technical infrastructure has a recapitalization rate of approximately 70 years. Emerging weapon system technology demands a higher rate of test capability recapitalization to ensure adequate weapon system testing. The current recapitalization period is more than seven times that of comparable private sector industrial facilities and does not provide effective T&E capabilities. To reestablish an adequate technical test infrastructure, we must strive to reduce its recapitalization rate to half the existing one.

The aging T&E infrastructure increases the probability of failures in test support capabilities that could cause significant and costly schedule slippages in acquisition programs. For example, in December 2000 equipment failures at Arnold Engineering Development Center (AEDC) required major repair actions and delayed test support to acquisition programs. An AEDC dryer cooler leaked 23,000 gallons of water and ethylene glycol that delayed two planned tests. A motor failure occurred in one of the 35,000 horsepower drive motors in AEDC's Propulsion Wind Tunnel causing the wind tunnel to operate at reduced capability for seven months.

---

<sup>3</sup> DoD Quadrennial Defense Review Report, September 30, 2001.

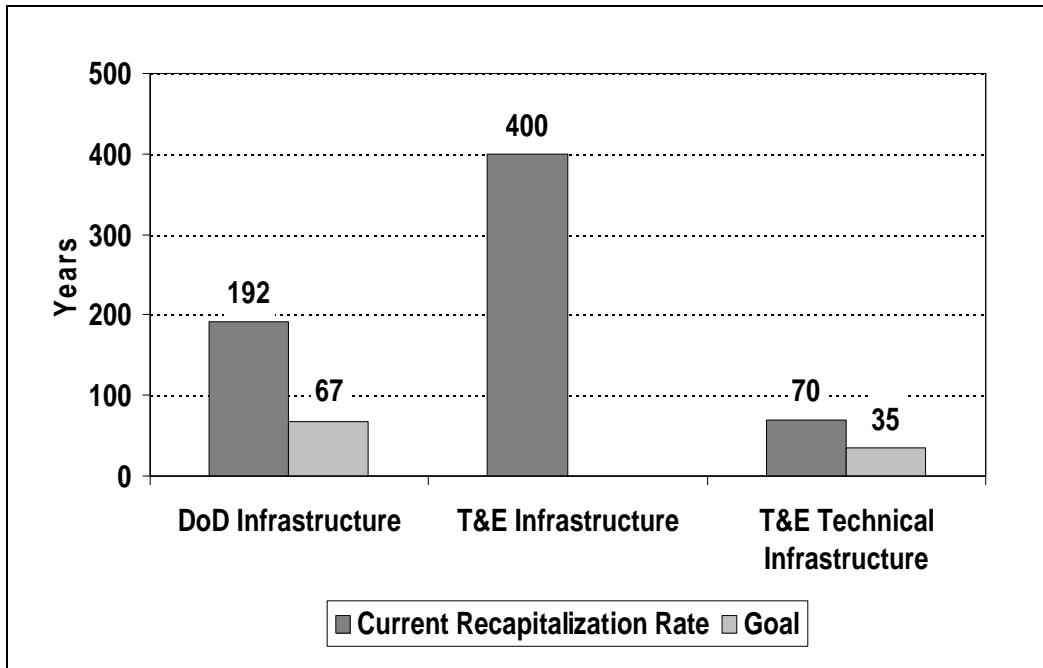

Figure 2. T&E infrastructure needs additional funding for recapitalization

**ADDITIONAL INVESTMENTS ARE REQUIRED TO ADD TEST CAPABILITIES FOR NEW SYSTEMS**

Investment funding for the T&E infrastructure provided over the past 10 to 15 years has not kept pace with the identified T&E needs, severely restricting our ability to adequately evaluate new technologies such as stealth, command and control systems, hypersonic weapons, and missile defense systems. Figure 3 shows the decline in the funding for modernizing the T&E infrastructure since FY90. In recent years, funding for targets and threat simulators has also been sharply reduced. The level of funding for improvement and modernization (I&M), while above the FY90 level, remains a fraction of that private industry invests in comparable high-technology infrastructure.

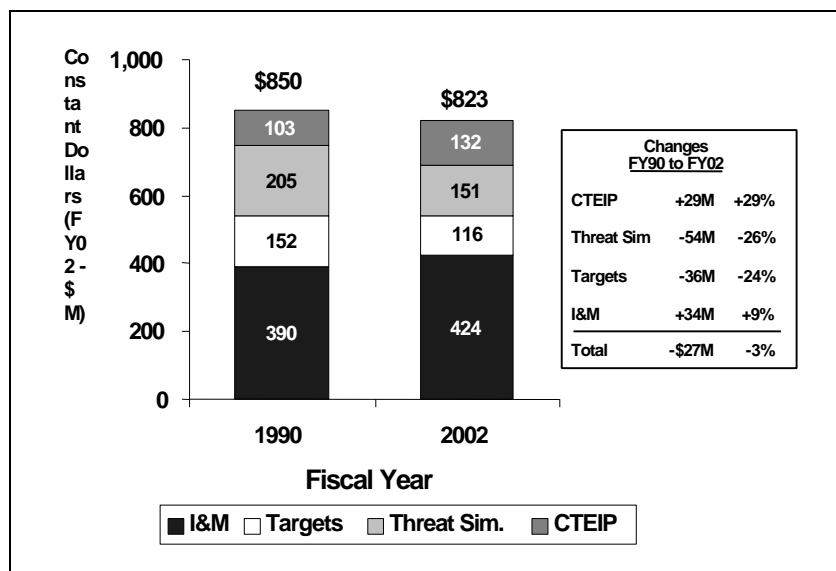

Figure 3. Total T&E investment funding has declined

Investment for T&E does not approach that appropriate for a high-technology enterprise. From FY02 on, significant funding increases are required to adequately test future weapon systems incorporating emerging technologies. DoD began the 1990s with a validated backlog of \$12 billion in T&E infrastructure modernization requirements.<sup>4</sup> With new requirements emerging at a growing rate, the backlog is continuing to grow.

### *Current investments are being made*

The principal programs for investment in the Department's T&E capabilities are: Service and Defense Agency Investment and Modernization (I&M) Programs and the Central Test and Evaluation Investment Program (CTEIP).

**Service and Defense Agency Investment and Modernization (I&M) Programs.** These programs provide funds for modernization of existing test capabilities and acquisition of new capabilities to meet the needs of the individual Service or Defense Agency. Each Military Service pursues an I&M program focused on their test facilities in areas that usually have limited tri-Service use or interest. The funding for Service I&M projects has increased modestly at a time when significant investments are needed for new technologies. Unfortunately, Service I&M requirements fail to compete effectively with other critical needs in the Service budget cycle. During the twelve-year period between the FY90 and the FY02 President's Budgets, total Service I&M funding increased less than \$35 million in constant dollars for an infrastructure worth \$25 billion.

**Central Test and Evaluation Investment Program (CTEIP).** The Central Test and Evaluation Investment Program (CTEIP) is an OSD-managed program established to improve T&E capabilities. CTEIP is the Department's corporate-level investment program for T&E capabilities that would be considered beyond a single Service's normal area of responsibility. Individual CTEIP investment projects are executed and implemented by the Services and Defense Agencies. In the past, CTEIP has focused not only on improving and standardizing range instrumentation but also on improving interconnectivity and interoperability among the ranges and acquiring advanced telemetry to meet demands for increasing data and data rates. Recent CTEIP investments focus on developing new capabilities that can be used by a variety of weapon systems with reduced need for user-interface development. Some example projects are:

- **Hardened Subminiature Telemetry and Sensor System (HSTSS).** This project developed an extremely small package of sensors, accelerometers, telemetry, and a power supply capable of withstanding very high-G environments. The instrumentation package can fit in the fuse well of an artillery shell. HSTSS vastly improves our ability to test emerging "smart weapons" that have expanded performance envelopes.
- **Airborne Icing Tanker (AIT).** The AIT project, nearing completion, is a multi-role KC-135R aircraft with an airborne icing capability that simulates natural rain and icing conditions in support of in-flight aircraft testing. Acquisition programs currently identified to use this capability are F-22, F/A-18 E/F, CV-22, MV-22, and Joint Strike Fighter. This national asset will also be available for environmental testing of commercial aircraft.
- **Transportable Range Augmentation and Control System (TRACS).** TRACS is a self-contained, transportable system designed to support test mission planning, test execution, real-time data collection and processing, mission control and flight safety, post-mission data

---

<sup>4</sup> DoD T&E Investment Initiative, T&E Resources Panel Workshop, February 1988.

analysis, and report generation. The system augments the capability of existing test ranges during peak requirements such as ballistic missile defense testing with multiple, simultaneous engagements. Different TRACS subsystems have been used to support numerous missile tests.

- **Translated GPS Range System (TGRS).** TGRS provides a new generation of instrumentation for time-space-position information. It provides real-time line-of-sight tracking and recording of high-quality signals for post-flight analysis of trajectories involving intercept and impact of target vehicles nearing the terminal phase of a ballistic trajectory. TGRS was used during recent National Missile Defense Integrated Flight Tests to provide accurate tracking of the targeted re-entry vehicle and the interceptor.

CTEIP has proved to be a critical investment mechanism for the Department to ensure critical T&E capabilities are developed and in place to support multi-Service and joint weapon systems. It provides the Department-level view, thus enhancing the joint warfighting concept, minimizing duplication in T&E infrastructure, and reducing total acquisition cost to the taxpayer. An annual report describing on-going CTEIP projects is provided to interested DoD and congressional staff in the February timeframe.

### *Shortfalls in the T&E infrastructure will affect acquisition programs*

When the capabilities of the test ranges are compared with requirements for testing current and future systems, significant deficiencies are evident. They limit the ability to conduct adequate testing of weapons and support systems. Some of the more significant deficiencies are:

- **Range infrastructure.** Inadequate compatibility exists between ranges (e.g., data acquisition and reduction systems, communications and data transmission systems, command destruct systems). Open-air test time on ranges is restricted as is ability to perform open-air jamming. Loss of radio frequency spectrum may inhibit test operations. Miss distance and attitude measurement systems lack adequate fidelity. Instrumentation shortfalls include limited radar, telemetry, and optical equipment assets to support multiple simultaneous engagements and insufficient instrumentation to track multiple vehicles. There are no chemical-biological test chambers large enough to accommodate complete systems. A replacement for the self-defense test ship is needed to retain the capability to demonstrate surface ship cruise missile defense systems.
- **Targets and threat representations.** Generally, realistic targets are not available in sufficient numbers to support the various weapon systems under development. Representative targets for certain anti-ship cruise missile threats are not available. Deficiencies exist in the quantity and types of ballistic missile defense targets. Threat representation shortfalls have also been identified. Needs include a vector-scoring capability on full-scale targets and improved capability for testing infrared missile engagements.
- **Realistic test environments.** New-generation systems have much more extensive operating footprints than their predecessors and, therefore, need much larger test ranges to support full-scale operational scenarios. Space test capabilities are not sufficient to meet space mission area testing requirements. Shallow water ranges for undersea warfare testing are inadequate. Chemical and biological simulators and simulants are not representative of the threat. Generally, there is a lack of priority and funding for testing of weapon systems in the extremes of their natural operating environments.

- **Interoperability.** Interfaces with other systems are not included in many test plans. Many systems are tested only on an individual basis. The failure to test systems with complementary ones in combined scenarios precludes effective assessment of their compatibility and ability to operate together.

### ***T&E needs science and technology projects to stay abreast of weapons test requirements***

Advances in weapon technologies and DoD's transformation initiatives will soon result in high-technology systems that cannot be adequately tested with the current test infrastructure. A T&E science and technology (S&T) program was approved for FY02 to expedite the transition of new technologies from the laboratory environment into T&E capabilities and to provide foundation technologies for a transformed test infrastructure. Such a program is essential to the continued viability of the test infrastructure. Initial funding of \$16 million is planned for the FY02 program. Efforts are underway to provide continuing funding for FY03 and beyond, eventually ramping to a steady-state funding level of approximately \$30 million per year.

T&E and S&T organizations have defined the critical technologies for the initial investments within this program. Focus areas for FY02 are spectrum efficiency, embedded instrumentation, information systems technology, space test, and hypersonics. In addition to initiating these projects, a long-range T&E technology roadmap will be prepared during FY02. The roadmap and successive updates will guide future investments and ensure that the program is focused and time-phased to meet the most critical T&E research and development shortfalls.

### ***Frequency spectrum encroachment requires investment***

Testing modern military systems, and training with these systems, relies heavily on the use of the radio frequency (RF) spectrum. Recent studies show that the DoD transformation initiative and the next generation of technology being incorporated into weapon designs will generate proportionately greater data rates that will exceed the capability of our current test infrastructure. Not only will these systems require more spectrum to operate but the telemetry data rate requirements will be more demanding. In addition, the growth in the demand for consumer communication services has resulted in pressure from the commercial telecommunications industry for the reallocation of RF spectrum from government to non-government use. The reallocation of telemetry spectrum coupled with the increased data requirements have raised concerns regarding the availability of adequate spectrum to support test and training.

We have made major strides in addressing these concerns by investing in CTEIP initiatives that support our goals for spectrum efficiency. Current CTEIP projects address improvements in the capabilities to use existing allocations of spectrum through such techniques as efficient modulation, data compression, real-time system management, and networking. However, it will be difficult to support the exponentially increasing data transfer requirements using only these techniques. In order to meet the increasing demand for more test data, we need to investigate the potential of using higher frequency bands to supplement our current limited capabilities and resources. An agenda item for the 2006 World Radiocommunications Conference is the expansion of the spectrum available for telemetry by adding frequency allocations in the 3-30 GHz range. In anticipation of these allocations, techniques must be developed to overcome significant technical difficulties in operating in these higher bands. CTEIP has requested additional funding to determine the technical requirements and limitations of these bands.

## **MANAGEMENT PROCESSES MUST BE IMPROVED TO MAKE TESTING EFFECTIVE AND EFFICIENT**

### ***A DoD T&E Resource Enterprise may provide efficient management***

The current approach to managing the DoD T&E infrastructure is through centralized oversight by DOT&E and decentralized funding and management by the Military Departments and Defense Agencies. Funding and manpower levels for the individual ranges and centers are programmed by the owning Service, even though the ranges may possess unique T&E capabilities which are used primarily by the other Services and Defense Agencies. This approach has led to a reluctance by the owning Service to fully fund and sustain some of these unique capabilities. The December 2000 Defense Science Board report<sup>5</sup> recognized this management issue. Its most significant recommendation, from a management standpoint, is that ownership and resource management of portions of the T&E infrastructure should be consolidated in a unified DoD T&E Resource Enterprise.

### ***Initial T&E strategic plan has been developed***

Last year, the Service Vice Chiefs and the DOT&E began the development of a T&E Strategic Plan. The plan includes a vision, goals, and objectives that will provide a path to modernizing the T&E infrastructure. The plan will institutionalize a strategic review as part of the T&E investment process to bridge the gap between today's capabilities and tomorrow's technology. In the near future, I intend to focus on completing the plan and developing the necessary actions to implement it. I expect to reenergize the strategic planning effort in March 2002 and complete the plan by the end of the calendar year. Detailed implementations planning should begin in September 2002. Of course, decisions on the Efficient Facilities Initiative and actions taken to implement the recent DSB report could affect these timelines.

### ***Sustainable range initiative is being pursued***

Over the last two decades, increasing challenges and limitations to the Department's use of its test and training ranges have arisen. Such range encroachment results from external factors, including urbanization, increasing environmental restrictions, and competition with civilian demands for airspace, land, ocean areas, and radio frequencies. The cumulative weight of these factors is increasingly recognized as a substantial threat to maintaining military readiness. To address this issue, the Defense Test and Training Steering Group (DTTSG), chaired by DOT&E, is leading a sustainable ranges initiative. Its purpose is to develop and implement a comprehensive strategy for access to range, frequency spectrum, and airspace essential to test and training needs. During 2002, we will develop a comprehensive set of legislative and regulatory proposals and formulate a multi-tier outreach effort with a goal of obtaining encroachment relief.

Sustainable range action plans for the following nine areas have been developed: Endangered Species Act and Critical Habitat, Unexploded Ordnance and Munitions, Frequency Spectrum, Maritime Sustainability, Airspace Restrictions, Air Quality, Airborne Noise, Urban Growth, and Outreach. Each action plan provides an overview and analysis of its respective encroachment issue area together with potential strategies and notional actions.

---

<sup>5</sup> Report of the Defense Science Board Task Force on Test and Evaluation Capabilities, December 2000.



## **REDEFINE POLICY AND FUNDING TO IMPROVE TEST EFFECTIVENESS**

Reduced operating funding for those major test ranges included in the Major Range and Test Facility Base (MRTFB) has resulted in a significant shift of test costs to test range users. This increase in users' cost to test has encouraged acquisition program managers to accept additional risk by curtailing developmental testing. Consequently, weapons systems have often performed less effectively than expected in OT&E.

Another resource concern is the workforce available to conduct T&E. Workforce reductions have adversely affected developmental testing at the major test ranges.

The mission scope of the operational test agencies (OTAs) has expanded, notwithstanding a decrease in workforce. This is further compounded by reductions in military personnel with operational backgrounds allocated to developmental testing.

### **INSTITUTIONAL FUNDING SHOULD BE INCREASED TO REMOVE AN IMPEDIMENT TO ADEQUATE TESTING**

The charge and funding policy used within the MRTFB was established to provide a uniform approach to charging costs across the major ranges and test centers. By policy, DoD test customers reimburse MRTFB activities for direct costs readily identifiable with a particular customer order (i.e., an individual test program). Costs not funded by customers are funded from direct appropriations of the Military Service or Defense Agency responsible for the particular test range or center. These are referred to as institutional funds. This charge and funding policy was intended to ensure that adequate test capability and capacity is available to DoD test customers when needed and at reasonable and predictable rates.

#### ***Institutional funding decreased dramatically during the 1990s***

Figure 4 shows the trends in test funding. The middle band of Figure 4 represents T&E institutional operating funds, which have been fairly constant since FY98 after falling nearly 25 percent during the prior eight years. The top band represents funding for military personnel. The chart shows that the funding represented by these two bands has decreased significantly.

The bottom band of Figure 4 is test customer funding. These funds are paid by customers for testing services provided by the test ranges and centers. User funding has remained relatively constant since FY90 but has increased in proportion to the total amount.

#### ***Decreases in T&E institutional funding have shifted costs to test infrastructure users***

The cost for testing at the MRTFB is increasingly borne by the users as institutional funding has declined. A recent analysis shows that about \$2.4 billion in test costs (previously funded in the MRTFB institutional budgets) have been shifted to the users since FY90. Eighty-five percent of the shift occurred during the last five years.

As institutional funds have fallen, the test ranges and centers have sought to recover more costs from users. The users, in turn, have reduced testing and accepted additional risk to remain within their budgets. Test adequacy has suffered as a consequence. In FY01, the MRTFB charged an estimated \$250 million per year more to users than was charged to them prior to FY90. Effectively, this means that, although users in FY01 collectively paid the same amount as in FY90, they are doing less testing.

The shift of costs could be corrected in either of two ways: (1) allocate additional funds to the programs and designate them for testing or (2) allocate additional funds to the Service institutional accounts. The first approach would give the appearance of cost growth and could require significant monitoring by the Office of the Secretary of Defense to enforce the policy. The second approach would increase institutional funding to a level that restores the MRTFB to the traditional “institutional share” (actual amounts would vary by Service). This would provide an opportunity for more testing within a program’s allotted test budget and reduce the negative incentive for users to conduct less testing.

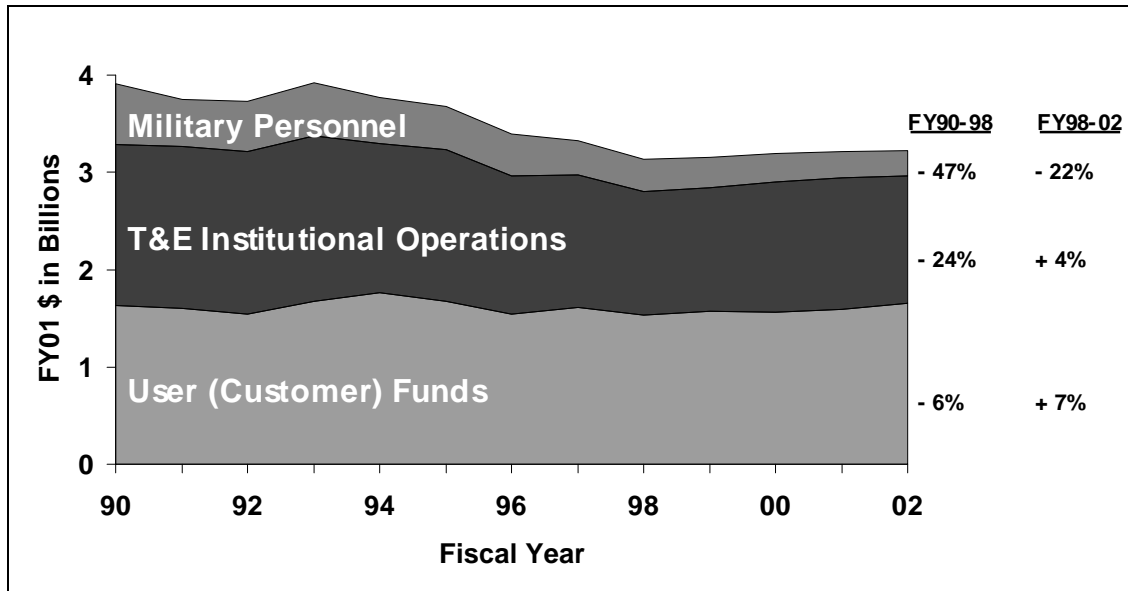
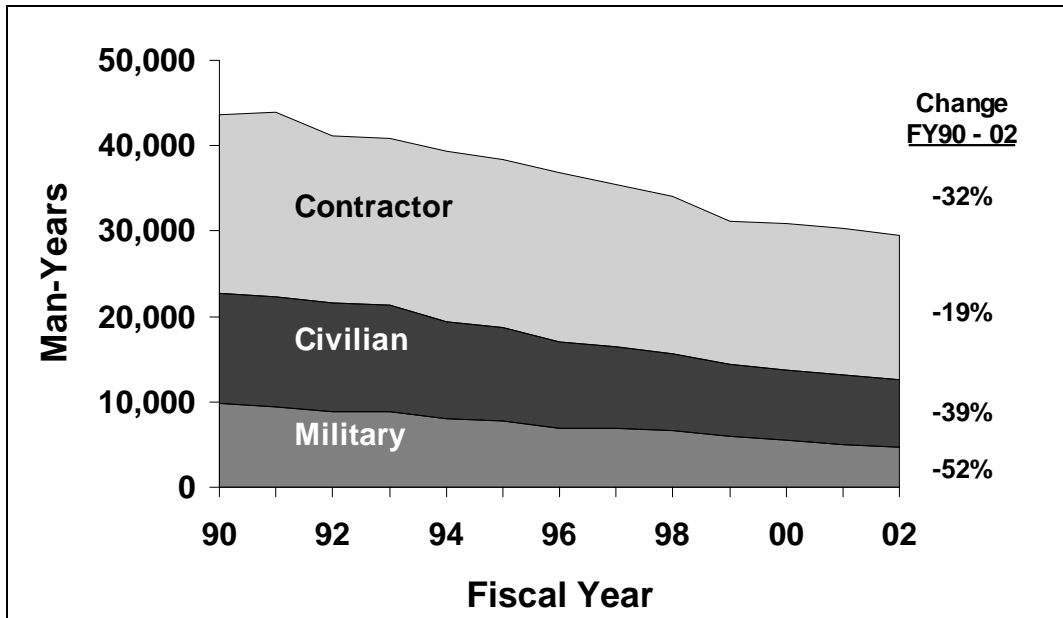

Figure 4. MRTFB funding has been reduced significantly

**WORKFORCE REDUCTIONS ARE ADVERSELY AFFECTING WEAPON SYSTEM TESTING**

The T&E workforce has declined by approximately one-third during the last decade despite a relatively constant workload. With few exceptions, MRTFB manpower has fallen steadily since FY90. Figure 5 displays the developmental test workforce. As is evident, all elements of this workforce are substantially smaller than they were a decade ago. Of particular concern is the dramatic decrease in the number of military personnel. Not having military personnel involved in early developmental testing results in missed opportunities to identify issues of military suitability and effectiveness.

In addition, there is anecdotal evidence that test centers are scheduling workload in a fashion that stabilizes the workforce at current levels. Such a practice adversely affects responsiveness to the needs of customers. This is a natural consequence of a smaller workforce. Also, because of limited resources for testing, emphasis is usually placed on minimizing test costs rather than minimizing the cost and schedule impacts on the weapon system acquisition program. This results in avoidable schedule delays and unnecessary program costs.



Figures 5. MRTFB workforce has been reduced substantially.

#### OPERATIONAL TEST AND OPERATIONAL TEST AGENCY RESOURCES SHOULD CONFORM TO REQUIREMENTS

Last year's report stated that Operational Test Agency (OTA) workload was increasing. That trend has continued and is expected to do so for the foreseeable future. Factors increasing the workload include:

- New acquisition policy directing an evolutionary acquisition process emphasizing both earlier involvement of operational testers and evaluators in system development and more continuous operational evaluations,
- Increased complexity of the T&E process resulting from introduction of advanced technologies at an increasing rate, and
- Need to test systems in more complex operational environments.

Early and continuous involvement is recognized as an effective means to gain operational insights into a system under development when flexibility in the design still exists. It also allows the Operational T&E Agencies to build a knowledge base from which to develop an effective operational test program. Early involvement expands workload in ways not captured by traditional metrics used to account for the OTA workload (e.g., number of tests and number of OT events). Such metrics capture the end result of the test process but do not provide visibility into individual test activities like integrated product team meetings, document reviews, and preparation of T&E master plans. Moreover, existing metrics do not reflect workload generated by testing more complex systems.

Figure 6, depicting OTA workload projections, does not fully reflect the trend of growing workload. Nevertheless, each OTA has experienced rising workload during the past eight years while both funding and personnel have decreased. Civilian personnel fell 45 percent and military personnel declined 35 percent. Some losses were offset by increases in the contractor workforce. However, the total workforce is 25 percent smaller than in FY93.

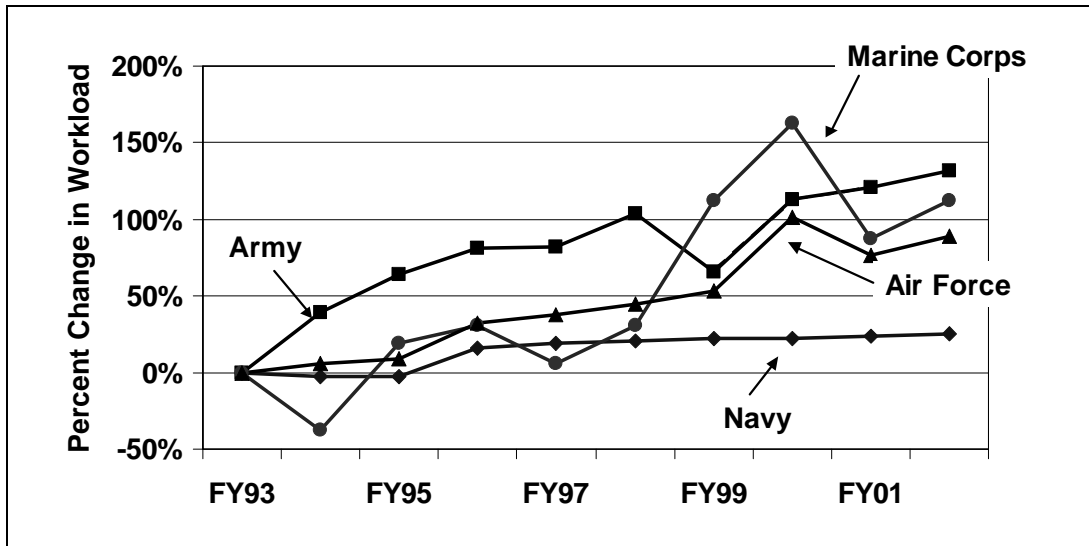

Figure 6. OTA workload is increasing

Figure 7 depicts the downward workforce trend as well as the changing mix in military personnel, government civilians, and contractors.

Another concern is the aging of the government civilian component of the workforce. Presently, the average age of OTA civil servants from GS-7 to GS-15 is over 50. An analysis of retirement eligibility indicates approximately 38 percent of the civil servants will be retirement eligible by FY05. Exacerbating this situation is that younger professionals are not being hired in adequate numbers to compensate for future losses. This is reflected in the fact that only 11 percent of the OTA workforce is less than 40 years of age.

Finally, I am concerned about the proportionately smaller military presence in the OTA workforce. Coupled with an aging civilian population, the small military presence represents the potential for a significant loss of experience and capability in the core government workforce. It also suggests that DoD dependence on contractor support may grow.

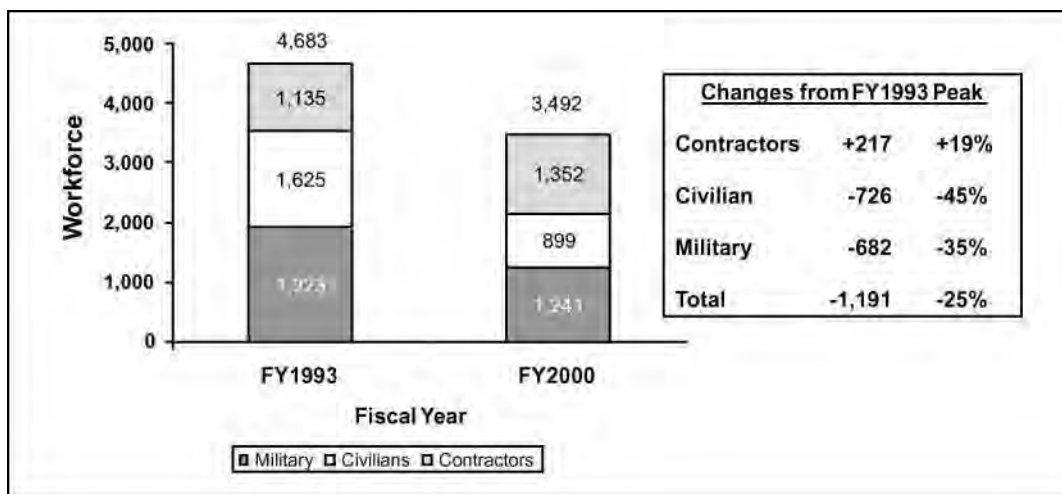

Figure 7. OTA workforce has declined

Adequate resourcing of the OTAs is imperative if we expect to determine system operational effectiveness and suitability and contribute to formulating operational employment doctrine. Consequently, I will pursue remedying the staffing and funding deficiencies at each OTA and ensure that operational testers are involved continuously through the development process.

## **SUMMARY**

Secretary Rumsfeld has called for giving “increased priority to maintaining a robust test and evaluation program, which will require test centers and ranges.... This need for testing - and particularly for testing capabilities conducted over very long distances - requires the Department to maintain and modernize highly instrumented ranges and to manage the challenges of range encroachment.”<sup>6</sup> I will strive to meet these challenges. DOT&E will continue to champion the need for additional resources for T&E as well as develop proposals to increase the ability of T&E to contribute to DoD’s acquisition programs. We must upgrade essential capabilities to meet the challenges presented by the increasing technological sophistication of our weapon systems and new operational concepts associated with DoD transformation efforts. Adequate investments in the T&E infrastructure will greatly enhance the ability of the acquisition process to deliver weapons systems that have been adequately tested to assure their effectiveness and utility to our warfighting forces.

---

<sup>6</sup> DoD Quadrennial Defense Review Report, September 30, 2001.

This Page Is Intentionally Left Blank

# **PART III**

## **ARMY PROGRAMS**





## **ABRAMS TANK (M1A2)**



The mission of the M1A2 SEP Abrams tank is to close with and destroy enemy forces using firepower, maneuver, and shock effect. The M1A2 SEP is being fielded to armor battalions and cavalry squadrons of the heavy force. SEP upgrades are intended to improve lethality, survivability, mobility, sustainability, and provide increased situational awareness and command & control enhancements. Specific changes include:

- The addition of two 2<sup>nd</sup> generation Forward Looking Infrared Radar sights (FLIRs).
- An under armor auxiliary power unit to power the tank and sensor suites.
- A thermal management system to provide crew and electronics cooling.
- Increased memory and processor speeds and full color map capability.
- Force XXI Battle Command, Brigade and Below (FBCB2) Integrated Combat Command and Control (IC<sup>3</sup>) to share battle command information and situational awareness with all components of the combined arms team.

In addition to the aforementioned SEP components, additional weight reduction measures, survivability enhancements, and safety improvements applied to the M1A2 were incorporated into the configuration that underwent LFT&E in FY01.

### **BACKGROUND INFORMATION**

The M1A2 IOT&E was conducted from September-December 1993. Based on the results of the IOT&E, the Director determined that the M1A2 was operationally effective but not operationally suitable, and unsafe. That assessment was based on poor availability and reliability of the tank and instances of the uncommanded main gun and turret movement and unintended .50 caliber machinegun fire. FOT&E II in June 1996 confirmed the adequacy of the applied corrective actions, and the Director assessed the M1A2 as both operationally effective and suitable.

The M1A2 SEP is a further upgrade to the M1A2 tank. OT conducted to date demonstrated an improved capability of the 2<sup>nd</sup> generation FLIR over the 1<sup>st</sup> generation FLIR to detect, recognize, and

identify targets at operationally relevant ranges. During FOT&E III, involving M1A2 SEP tanks and baseline M1A2 tanks, the M1A2 SEP demonstrated a significantly better performance during night engagements over the baseline M1A2 in the number of targets hit. During day engagements, no performance difference was detected between the M1A2 SEP and the baseline M1A2.

The M1A2 SEP, along with the additional engineering changes included since 1993, sometimes referred to as the M1A2 Tank 2000, is an LFT&E covered product improvement requiring an LFT&E program. In July 1999, the Director approved an M1A2 Tank 2000 LFT&E strategy that included both component-level and system-level testing conducted in FY01.

### **TEST & EVALUATION ACTIVITY**

The U.S. Army conducted the M1A2 SEP FOT&E IV in conjunction with the M2A3 Bradley Fighting Vehicle IOT&E at Fort Hood, Texas, during the period September-October 2000. It was structured to compare the operational effectiveness and suitability of the M1A2 SEP against the currently fielded M1A2. The Army conducted the test in accordance with an approved plan and DOT&E monitored the test on site and conducted an independent evaluation.

Phase I LFT&E activities were completed in FY01. Phase I addressed M1A2 SEP specific design features with component-level ballistic shock tests, non-destructive tests, and engineering analyses. Ballistic shock tests of the improved Gunner's Primary Sight with its 2<sup>nd</sup> generation FLIR were conducted in January and February 2001.

Phase III system-level live fire tests were conducted between October 2000 and July 2001. Phase III comprised three system-level live fire tests, and fourteen full-up, system-level live fire tests. The tested threats included hand-held infantry weapons, mines, artillery, anti-tank guided-missiles, and tank-fired munitions. In addition to performing detailed assessments of system damage following each test, most test events provided opportunities for representative crews and maintenance teams to exercise Battle Damage Assessment and Repair procedures to assess training and techniques. Damage assessment team meetings concluded in August 2001. Initial test reports, evaluations, and assessment briefings were disseminated in December 2001.

### **TEST & EVALUATION ASSESSMENT**

The M1A2 SEP is operationally effective. Overall, the M1A2 SEP showed an improved level of operational effectiveness in comparison to the M1A2. This improvement in operational effectiveness is attributed to the M1A2 SEP's superior capability compared to the M1A2 to detect, identify, and hit targets as well as the M1A2 SEP's improved night fighting capability as demonstrated in FOT&E III and a Detection, Acquisition, Recognition, Identification (DARI) test.

The M1A2 SEP met the specified reliability requirements and did better than the baseline M1A2s. However, there were many failures attributable to the IC<sup>3</sup> and FBCB2. These failures were not severe enough to be considered combat mission failures but did markedly degrade the command and control systems. If these failures had been included in the reliability evaluation, the M1A2 SEP would not have met its reliability requirements. The M1A2 SEP also met its availability and maintainability requirements.

IC<sup>3</sup> was designed to meet a key system requirement for digital battle command and is the M1A2 SEP link to FBCB2. Technical testing conducted on the M1A2 SEP indicated that the system's IC<sup>3</sup> was sufficiently mature to enter FOT&E IV and successfully demonstrate system digital C<sup>2</sup> requirements. However, the system performed poorly in FOT&E IV.

The FOT&E III, FOTE IV and the DARI were adequate to determine the operational effectiveness and suitability of the M1A2 SEP. These events were deemed adequate by DOT&E despite three significant shortfalls: (1) immature FBCB2 hardware and software; (2) the absence of Army Tactical Command and Control Systems did not allow demonstration of Army Battle Command Systems (ABCS) interoperability (for example; automated calls for artillery fire); and (3) the marginal performance of the Mobile Automated Instrumentation System Real Time Casualty Assessment. In spite of these shortfalls, the M1A2 SEP demonstrated an improvement in operational effectiveness over the baseline M1A2 and met its suitability requirements.

FOT&E IV was conducted with only the FBCB2 component of the Army Battle Command System. M1A2 SEP-equipped units are scheduled to participate in future FBCB2 OT events, allowing for the opportunity for the M1A2 SEP to demonstrate full interoperability with the remaining components of ABCS.

This Page Is Intentionally Left Blank

## **ADVANCED FIELD ARTILLERY TACTICAL DATA SYSTEM (AFATDS)**



The Advanced Field Artillery Tactical Data System (AFATDS) is a network of computer workstations that processes and exchanges information from the forward observer to the fire support element for all fire support assets (field artillery, mortars, close air support, naval gunfire, attack helicopters, and close air support). Features include the automatic processing of fire requests; generation of multiple tactical fire solutions for missions; monitoring of mission execution; and support for the creation and distribution of fire plans. The Marine Corps has also acquired AFATDS, which is one of the battlefield functional areas comprising the Army Battle Command System (ABCS).

### **BACKGROUND INFORMATION**

The AFATDS IOT&E in 1995 supported an assessment of operationally effective and suitable for Milestone III. The 1996 AFATDS IOT&E Verification Limited User Test (LUT) confirmed solutions for shortfalls from the IOT&E, except for fire planning, where occasional fire mission deletions and system crashes were observed following transmission of the fire plan. Subsequently, AFATDS 96 software and Common Hardware System (CHS) hardware entered full production and fielding.

AFATDS completed a LUT in October 1997, supporting a material release of AFATDS 97 software on newer CHS platforms. The first operational assessment of AFATDS involving Marine Corps units occurred at Twentynine Palms, CA, in March 1998. The tested hardware and software configurations did not support Marine Corps mobility requirements; however, the participating artillery units considered the automated support provided by AFATDS acceptable.

The AFATDS 98 LUT, a joint Marine Corps and Army event, was conducted in 1998 and examined AFATDS 98 software, the first version developed to address specific Marine Corps requirements, provide theater level targeting, and improve air support functionality. The AFATDS 98 LUT also examined several versions of hardware, including the Compact Computer Unit that reduces system size and weight. The AFATDS 98 Fixes LUT was conducted in 1999 at Fort Sill, OK. This test demonstrated solutions to deficiencies identified in the AFATDS 98 LUT and included air operations, Naval surface fire support, trigger events, fire planning, Multiple Launch Rocket System (MLRS) units, and attack aviation.

## **TEST & EVALUATION ACTIVITY**

The AFATDS 99 LUT was conducted at Fort Sill, OK, from February to March 2001. The AFATDS 99 LUT's purpose was to evaluate the AFATDS 99 software to support a material release. New functionality tested included technical fire direction of the Battery Computer System for tube artillery, technical fire functionality of the Fire Direction System for the MLRS, tactical interoperability with legacy field artillery systems, and Army and Marine Corps air operations.

An additional test, the AFATDS 99 Fixes LUT, was conducted in September 2001 to retest the deficiencies from the February LUT. The Fixes LUT executed the same scenario in the previous LUT and was conducted at Fort Sill, OK.

## **TEST & EVALUATION ASSESSMENT**

AFATDS IOT&E in 1995, along with AFATDS 96 software, established the core capability for this program. Initial functionality has been increased with testing and fielding of AFATDS 97 and AFATDS 98. Corrections to all IOT&E identified problems have been demonstrated. The AFATDS 99 adds technical fire direction and was originally intended to evaluate horizontal interoperability with the other ABCS systems (Maneuver Control System, All Source Analysis System, and Force XXI Battle Command Brigade and Below). This part of the test and assessment was postponed until the horizontal integration matured.

The FY01 AFATDS 99 LUT did not adequately demonstrate the technical fire direction functionality of the tube artillery or MLRS. Nor did it demonstrate the capability to conduct adjust fire missions or precision registrations. A contributing factor was the AFATDS operators' general lack of knowledge and understanding of air mission processing. The Army Test and Evaluation Command has not yet published the OA of the September FY01 Fixes LUT. However, preliminary insights show a marked improvement in system and operator performance, but not sufficient to support a material release decision.

The remaining issues include testing of future upgrades within the system-of-systems concept and interoperability with the ABCS as employed in the First Digital Division. The Army has prepared a new TEMP for AFATDS 99 testing, but it needs to be augmented with the AFATDS horizontal testing required to operate with ABCS Version 6 software systems.

The ability to evaluate the ABCS components as individual programs is becoming more difficult as the Army continues to integrate the software and foundation products that comprise these systems, as well as integrate the information into the Common Tactical Picture. An assessment of operational effectiveness and suitability is no longer limited to what the system provides within a single functional area (fire control for AFATDS), but now expands to what does the integration of that information with other functional areas provide to the commander's ability to prosecute the mission. Testing must be done with all the ABCS components present to assess operational effectiveness and suitability. The Department should begin to look for Capstone acquisition, development, testing, and fielding strategies to more effectively and efficiently support, fund, and synchronize the ABCS programs.

## **AH-64D LONGBOW APACHE & LONGBOW HELLFIRE MISSILE**

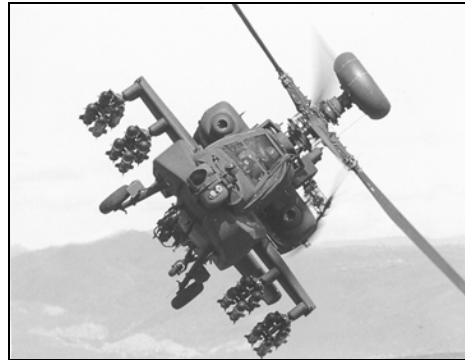

The AH-64D Longbow Apache is a remanufactured and upgraded version of the AH-64A Apache attack helicopter. The primary modifications to the basic Apache are the addition of a millimeter-wave Fire Control Radar (FCR) target acquisition system, the fire-and-forget Longbow Hellfire air-to-ground missile, updated T700-GE-701C engines, and a fully integrated cockpit. In addition, the aircraft has improved survivability, communications, and navigation capabilities. Most existing capabilities of the AH-64A Apache are retained.

The AH-64D is being fielded in two configurations. The full-up AH-64D includes all of the improvements listed above. The other version of the AH-64D does not have the FCR, Radar Frequency Interferometer, or the improved engines. The AH-64D without FCR is more affordable, yet remains capable of employing Longbow Hellfire missiles autonomously or in cooperation with the FCR-equipped AH-64. Present plans call for 501 AH-64A Apaches in the fleet to be upgraded to the AH-64D configuration. Approximately half (227) will be equipped with the FCR. This is an ACAT IC program.

Managed by the Army as a separate program, the Longbow Hellfire missile is a radar-guided version of the laser-guided Hellfire anti-tank, air-to-ground missile. The Longbow Hellfire features an active millimeter wave seeker and a dual tandem warhead designed to defeat reactive armor. Either the Fire Control Radar or the Target Acquisition and Designation Sight can be used to provide target location data to the missile prior to launch. The Longbow Hellfire can engage both moving and stationary vehicles.

The mission of the attack helicopter is to conduct rear, close, and deep operations; deep precision strikes; and armed reconnaissance and security when required in day, night, or adverse weather conditions.

### **BACKGROUND INFORMATION**

The 1995 combined Longbow Apache and Longbow Hellfire IOT&E compared the AH-64D Longbow Apache with the baseline AH-64A Apache aircraft. Both the Longbow Apache and baseline Apache units conducted missions against a battalion-sized enemy ground force augmented with formidable air defenses while a real-time casualty assessment system imposed realistic friendly and enemy losses. The AH-64D force was significantly more lethal and survivable than the AH-64A force,

primarily as a result of major improvements in situational awareness, reduced exposure to enemy air defenses, and increased engagement ranges.

One issue uncovered during IOT&E that required follow-on testing involved a method of employment for the Longbow Hellfire missile. During IOT&E, Longbow Apache crews preferred to override the automatic firing mode selection and fire missiles from a masked position using the Lock-On Before Launch Inhibit (LOBL-I) firing mode. This technique significantly increased the helicopter's survivability during IOT&E, but had not been validated with live missile firings during preceding DT/OT.

DOT&E worked with the Army to develop a plan for a Follow-On Test of the LOBL-I engagement to confirm system performance using this firing technique. The test program included digital simulations, Hardware-in-the-Loop testing of the guidance section, low-speed captive flight test (LSCFT) of the missile seeker, and live missile firings at moving armored vehicles. The simulations, LSCFT, and four of the planned eight missile firings were completed in FY99. The Army successfully completed the remaining four of the eight target engagements with the Longbow Hellfire missile in FY00.

As the ongoing procurement of the Longbow Apache continues, the configuration of the aircraft will change to improve system reliability and survivability. The changes of particular interest to DOT&E include the aircraft's new portable fire extinguisher (located in one of the outer storage bays), the possible integration of the Suite of Integrated Infrared Countermeasures (with a focus on the advanced flare dispenser and the advanced flares), and the integration of the internal auxiliary fuel system (IAFS) (a new crashworthy and ballistically tolerant fuel tank and ammunition magazine located internal to the aircraft). The Army is working to develop a sub-system level ballistic vulnerability test plan for the IAFS to ensure that it will not adversely affect the survivability or vulnerability of the system. DOT&E will continue to monitor development and testing of these configuration changes.

## **TEST & EVALUATION ACTIVITY**

No operational or live fire test events occurred in FY01. However, an incident during live fire training exercises with the Hellfire missile has implications for future testing. In October 2000, 19 Apache (AH-64A) Helicopters were damaged by debris from Hellfire Missiles manufactured with Alliant Tech/Hercules rocket motors. The debris poses an unacceptable safety risk to the tail rotor system. Therefore, the Army has suspended use of the Longbow Hellfire missile inventory and half of the Laser Hellfire missile inventory except for emergency or wartime use. In the near term, live fire training will continue with missiles with Thiokol rocket motors. For the long term, rocket motor design is underway and qualification testing will be complete by the end of FY02. DOT&E will closely monitor this testing to ensure adequacy of the new design before retrofitting begins. A total of 4,784 Longbow Hellfire missiles and 5,169 Laser Hellfire missiles are to be retrofitted.

## **TEST & EVALUATION ASSESSMENT**

Preliminary results from the simulation and test firing of LOBL-I missiles indicate the issues raised during IOT&E have been resolved. Ultimately, the Hellfire missiles hit their intended targets in all eight of the planned test scenarios and the missile firings were consistent with the simulation results. The simulations suggest that the Longbow Hellfire missile can successfully engage moving targets using the LOBL-I firing mode, provided that the time between target detection and missile launch is not



excessive. Unfortunately due to resource constraints, the Army has not been able to complete their analysis of the simulations and FY00 missile firings. DOT&E expects the Army's report in 2QFY02 addressing the success and resulting tactics, techniques and procedures recommendations.

The LFT&E IPT reviewed all of the changes to the Apache helicopter since Full-up, System Level LFT&E in 1995, and has determined that they do not effectively change the vulnerability of the aircraft. The only outstanding LFT&E requirement is the completion of the engine fire detection and suppression system test and the ballistic vulnerability sub-system test of the IAFS.

The Army is committed to conducting the engine fire detection and suppression system test required by the Apache Longbow Test and Evaluation Master Plan. This test was deferred so that it could be conducted with the Army Aviation Halon replacement.

A suitable replacement (i.e., drop-in replacement) is currently not identified. As a result, the PMO has agreed to conduct this test with Halon, or the Halon Replacement agent if reasonably integrated on the airframe in time for test completion in FY03. The Army is working to complete the testing by that timeframe.

This Page Is Intentionally Left Blank

## ALL SOURCE ANALYSIS SYSTEM (ASAS)



The All Source Analysis System (ASAS) is a network of computer workstations that processes and exchanges sensor data, fuses multi-source data into a single intelligence picture, and supports management of intelligence sensors. It is tactically deployable, supports intelligence and electronic warfare operations at battalion through echelons above corps, and provides interoperability with joint intelligence and sensor systems. Intelligence provided by ASAS allows commanders to identify key points for dominant maneuver and find high priority targets for precision targeting.

### **BACKGROUND INFORMATION**

The original ASAS requirements were approved in 1986. Subsequently, the requirements were structured so that ASAS could be developed, acquired, and fielded in discrete increments or blocks. ASAS Block I successfully completed its Operational Test (OT) in 1993 and is fielded to selected theater, corps, and division units throughout the Army. The current Block II development is structured so that the interim capability is attained through a series of stand-alone products that can be tested and fielded when they are ready. The ASAS Remote Workstation (RWS) began fielding after completing its OT in March 1999. An upgrade to the Communications Control Set obtained a conditional material release in June 1999 following a series of developmental tests. The Analysis Control Team Enclave (ACT-E), a shelter for the team at brigade, successfully completed testing and started fielding in September 2000. The future ASAS Block III is the objective capability.

### **TEST & EVALUATION ACTIVITY**

Planning continues for the remaining ASAS Block II products. The focus for CY02 is testing of the ASAS Remote Workstation implementing the Army Battle Command System (ABCS) Version 6 software. Planning also continues for the FY03 Analysis and Control Element operational test that will serve as an IOT&E for the ASAS Block II and support a full-rate production decision. The Army is exploring combining the Block II IOT&E and Distributed Common Ground Station testing.

The ASAS Light, a downsized, laptop version of the ASAS RWS at battalion, obtained a conditional material release and began fielding in FY01 supported by the Army's Limited User Test (LUT) assessment conducted in FY00.

## **TEST & EVALUATION ASSESSMENT**

The ASAS Light LUT conducted in FY00 showed that it provided the required functionality and contributed to intelligence preparation of the battlefield and planning in the battalion. However, contributions to the firefight were limited due to poor integration into the unit's operations, integration of digital technology into tactical command posts, and connectivity using existing combat net radio networks. Corrections to these shortcomings will be assessed again during the ASAS RWS operational test events planned for CY02.

There were no tests conducted in FY01 on the ASAS components. However, a significant issue for the upcoming assessment of the ASAS RWS in CY02 is the synchronization of ABCS Version 6 software testing and acquisition decisions. The ABCS Version 6 software is an integrated suite of applications comprised of independent acquisition programs (ASAS, Maneuver Control System, Advanced Field Artillery System, Forward Area Air Defense, Combat Service Support Command and Control, Force XXI Battle Command Brigade and Below). The ability to test, acquire, and field any component of the ABCS independent of the others is problematic; an appropriate strategy by the Army remains unclear.

Evaluation of the ABCS components as individual programs is becoming more difficult as the Army continues to integrate the software and foundation products that comprise these systems, as well as integrate the information into the Common Tactical Picture. An assessment of operational effectiveness and suitability is no longer limited to what the system provides within a single functional area (intelligence for ASAS), but now expands to what does the integration of that information with other functional areas provide to the commander's ability to prosecute the mission. Testing must be executed with all the ABCS components present to assess operational effectiveness and suitability. The Department should begin to look for Capstone acquisition, development, testing, and fielding strategies to more effectively and efficiently support, fund, and synchronize the ABCS programs.

## **ARMY MULTIFUNCTIONAL INFORMATION DISTRIBUTION SYSTEM-LOW VOLUME TERMINAL 2 (MIDS-LVT 2)**



The Army Multifunctional Information Distribution System-Low Volume Terminal 2 (MIDS-LVT 2) provides Link 16 digital data communications to Air and Theater Missile Defense Command and Control (C2) host systems. Link 16 provides a common relevant operational picture of theater air activity via a robust, jam-resistant network for Joint and Multinational Force data sharing.

The Army MIDS System includes the MIDS-LVT 2 terminal, the Joint Tactical Information Distribution System (JTIDS)/MIDS-LVT 2 Terminal Controller (TC), and the antenna. The TC consists of specialized software hosted on a personal computer and provides initialization and status monitoring functions.

Planned MIDS-LVT 2 host platforms include the Theater High Altitude Area Defense (THAAD) System, the PATRIOT Information and Coordination Center (ICC) and Battery Command Post (BCP).

### **BACKGROUND INFORMATION**

The Army procured the JTIDS Class 2M terminal and fielded it in Forward Area Air Defense (FAAD) C2 systems and PATRIOT ICCs. The Army concluded acquisition of the JTIDS Class 2M terminal and intends to satisfy the remaining host platforms' Link 16 requirements with MIDS-LVT 2. MIDS-LVT 2 shares some common components with MIDS-LVT 1 but has less functionality. For example, MIDS-LVT 2 does not have Link 16 digital voice or Tactical Air Navigation.

The Army conducted a MIDS-LVT 2 Limited User Test (LUT) during FY99. This test revealed a number of critical technical and operational deficiencies with the EMD MIDS-LVT 2 terminal, TC, Link 16 network initialization, operator training, message handling, displays, and Built-In Test.

During 3QFY00, the Army initiated LRIP. These LRIP terminals will support host platform integration, engineering, and IOT&E scheduled for 3QFY02. A MIDS-LVT 2 full-rate production decision is planned for 4QFY02.

## **TEST & EVALUATION ACTIVITY**

In 2001, the Army conducted a 30-day reliability DT of EMD terminals, a three-day confirmatory DT event, and a MIDS-LVT 2 Functional Verification Test (FVT). The confirmatory test examined corrective actions to LUT deficiencies. The FVT was conducted using hardware-in-the-loop laboratory and host platform assets, along with test and scenario simulation tools. The objective of the FVT was to demonstrate the capability of THAAD, PATRIOT, and FAAD systems to interface with MIDS-LVT 2.

MIDS-LVT 2 BCP integration, as well MIDS-LVT 2 integration into THAAD, is unique because the TC function is integrated into the host platforms' computers and displays. This configuration will eliminate the TC, a source of numerous deficiencies, from the system.

## **TEST & EVALUATION ASSESSMENT**

Although a robust schedule of DT is planned for FY02, there are no operational test (OT) events prior to Army MIDS IOT&E. The absence of a combined DT/OT or dedicated OA event presents risk for a successful IOT&E. The IOT&E will evaluate MIDS LRIP terminals integrated into the PATRIOT ICC and BCP, a new host platform for Link 16. The BCP will initially be fielded with JTIDS; however, this integration will not have been evaluated in an OT.

Lessons from previous Army Link 16 tests indicate reliability challenges for systems operated and maintained by soldiers in field conditions. Because of these potential trouble areas, DOT&E has recommended that the Army develop a pre-IOT&E OT event to determine the risk to successful IOT&E.

In a reliability test, MIDS-LVT 2 demonstrated a reliability point estimate of 432 hours Mean Time Between Failure (MTBF). MIDS-LVT 2 failed to operate consistently when coming out of cold temperature cycles and there were hardware failures requiring replacement. These results indicate that MIDS-LVT 2 did not meet the 1,000-hour threshold requirement and there is risk that MIDS-LVT 2 will fail the operational reliability requirement of 393 hours MTBF.

While the DT events indicated that many of the LUT deficiencies had been corrected, 13 new deficiencies, ranging from physical safety to message handling were discovered. The most serious include incorrect processing of the Link 16 theater missile defense space track message by MIDS-LVT 2. The processing of the space track message results in track velocity and positional errors, and may result in critical delays in engagement of incoming theater ballistic missiles.

More emphasis should be placed on training. Operation in a Link 16 network is complex and requires sustainment training for the users to maintain skills. The LUT indicated shortfalls in network monitoring and troubleshooting. Evaluations of other Service MIDS have also identified training deficiencies. In general, Link 16 operators are not afforded adequate practice with the actual hardware and software they will operate in the tests or in the field.

Link 16 joint interoperability is ensured by adherence to the common Link 16 waveform, standard message sets, and Link 16 network designs. During FY00 tests, it was apparent that incorrect host platform implementation of Link 16 messages resulted in loss of mission functionality in other Link 16 network participants. DOT&E will continue to stress early and complete Link 16 interoperability certification, for the host platform, before entry into IOT&E. This certification will be followed by live operational test events, with most events leveraged on Joint Field Training Exercises, and include evaluation of Link 16 network and message interoperability.

## **ARMY TACTICAL MISSILE SYSTEM (ARMY TACMS) BLOCK II / BRILLIANT ANTI-ARMOR (BAT)**

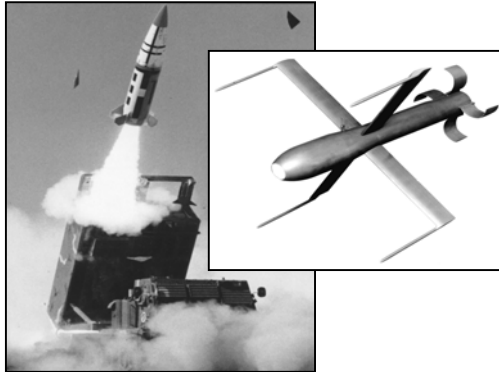

The Brilliant Anti Armor (BAT) is a self-guided submunition that uses on-board sensors to seek, identify, and engage enemy combat vehicles. Thirteen BATs are dispensed from the Army Tactical Missile System (TACMS) Block II missile. The Army has been developing two BAT variants. The basic BAT variant is designed to engage moving armored vehicles using acoustic and infrared sensors. The acoustic sensor acquires and guides the submunition to the moving vehicles. Once in the vicinity of a threat vehicle, the infrared sensor guides the BAT to its aimpoint, where it uses a tandem-shaped warhead to destroy the vehicle. This precision engagement capability is designed to provide joint U.S. and combined forces a capability to interdict enemy formations at depth, contributing to dominant maneuver.

The pre-planned product improvement (P3I) BAT variant is designed to attack moving and stationary armor as well as transporter-erector-launchers (TEL) and multiple rocket launchers (MRL). As with the Basic BAT, P3I BAT will use acoustic sensors to initially acquire moving vehicles. Once acquired by the acoustic sensor, the P3I BAT uses its millimeter wave and imaging infrared sensor to track the target to impact. When the system engages stationary targets (armored vehicles and TELs and MRLs), the P3I BAT will use its millimeter wave and imaging infrared sensors to detect, acquire, and track a target to impact.

### **BACKGROUND INFORMATION**

Both Army TACMS Block II and Basic BAT were approved to enter low-rate production in February 1999. The P3I BAT commenced development in July 1999. A Defense Acquisition Board (DAB) decision to change production from Basic BAT to P3I BAT will be made in December 2003. Due to poor performance, the Army cancelled IOT&E of the Basic BAT after completing two of the five planned missions. Due to this recent cancellation, OSD approval of a revised P3I BAT acquisition strategy is pending.

### **TEST & EVALUATION ACTIVITY**

Basic BAT technical and operational testing for the past year has focused on missile firings of the Army TACMS Block II/BAT. There were three missile flights (39 BATs) this year. The operational

tests were conducted in accordance with the DOT&E approved TEMP and OT test plans, and DOT&E observed all flights.

P3I BAT conducted the final captive flight tests at Grayling, MI, to collect target signatures and develop submunition algorithms. In May 2001, the contractor conducted a recoverable BAT (RBAT) engineering test. RBATs have similar hardware and algorithm to the P3I BAT. However, when an RBAT locks onto a target, it briefly tracks it and deploys an additional parachute so that it can be recovered. Hence, multiple tests can be conducted with the same hardware. The engineering test uncovered technical problems with the RBAT recovery system and the millimeter wave and infrared sensors, which the contractor is addressing. The next RBAT test is scheduled for early 2002.

Basic BAT LFT&E activities continued in FY01. The most significant accomplishment was the completion in March 2001 of the seven Basic BAT rail shots against a T-72 tank. P3I BAT LFT&E activities also continued in FY01.

DOT&E continues to work with the Army to develop a robust test and evaluation strategy (both OT&E and LFT&E) for Army TACMS Block II/ P3I BAT, which will be included in an updated TEMP.

## **TEST & EVALUATION ASSESSMENT**

Performance, weather robustness, and system targeting are areas of concern. There were three missions fired as part of the operational test, with limited success. In the first mission, there were no hits. The aimpoint of the missile was adjusted to simulate the error in targeting during combat. The target array consisted of moving threat vehicles, with Defense Intelligence Agency approved countermeasures. Winds contributed to poor performance by creating significant background noise, making difficult the detection of the target array by the acoustic sensors.

The next mission was a technical test, with the same countermeasures. A small operational targeting error was chosen to optimize effectiveness. Two armored personnel carriers (BMPs), one with a camouflage net countermeasure, and one with the full countermeasure) and one truck were hit. The truck hit does not count in scoring for BAT.

The third mission was fired against a dispersed array of three moving columns. The two flank columns were comprised of stationary targets at high idle. The center column was moving. No targets had countermeasures. Four targets were hit (one of them twice) in a flank column. Analysis indicates that the BATs had high acoustic background noise, miscalculated altitudes, and other problems. Most of these problems were likely caused by turbulent air conditions. The project office is investigating whether corrective actions are required.

BAT submunition reliability is below the ORD threshold. DOT&E scored 84 percent (31/37) of the production representative BATs reliable. The Milestone III requirement is 91 percent. A BAT is scored reliable if it functions as designed. This is a measure of hardware and software reliability, not mission effectiveness. A reliable BAT can miss a target.

The contractor had problems delivering Army TACMS Block II missiles with all BATs functional. This year, two of the five missiles delivered to the range had one BAT test badly. When fielded, the Army plans to conduct periodic testing of the missile stockpile. If only one BAT tests bad, then the missile will be kept in the stockpile. The contractor was allowed to replace the BATs in both missiles because they were DT events.



Missile firings to date indicate that the missile will meet its accuracy requirement. Also, 100 percent (37/37) of the production-representative BATs were successfully dispensed.

The LFT&E strategy for the weapon system was developed to take advantage of expected hits on armored vehicles during the planned flight tests of Basic BAT submunitions with live warheads. There have been 30 BAT drops/dispenses with live warheads that have been scored to date; seven of these have detonated on targets (including tanks and light armored vehicles). These test results, along with the detailed lethality results from the seven shots against a T-72 tank in dedicated LFT, should provide sufficient data to determine whether the Basic BAT submunition can meet its lethality requirements, given a hit against moving armored vehicles.

Accuracy and command and control tactics have been adequately demonstrated thus far in the program. As part of Block II/BAT's total system evaluation, a command and control operational test was completed in May 2000. This test examined the ability of the Army's command and control system to track and target large armored columns. The operational test showed that the Army could produce targeting errors that are within Block II/BAT's stated operating parameters. Due to the cancellation of operational testing, Block II/BAT's ability to overcome these operational errors will not be demonstrated. The Block II/P3I BAT IOT&E must now demonstrate this ability.

The ability to find and locate Block II/BAT targets is an area of concern. The Joint Surveillance Target Attack Radar System (JSTARS) is the only targeting source for an Army TACMS Block II/BAT target set, comprised of armored columns moving deep in the battlefield. The Army conducted a technical demonstration of JSTARS' ability to acquire Army TACMS Block II/BAT targets. The demonstration showed that, if JSTARS is available, it is capable of producing accurate and timely data in flat terrain with little radar clutter and no extraneous targets. However, JSTARS was not available to provide targeting information for half of the 3 days of testing due to reliability problems. It is questionable whether JSTARS will be available consistently to provide targeting information.

This Page Is Intentionally Left Blank

## **BATTLEFIELD COMBAT IDENTIFICATION SYSTEM (BCIS)**



The Battlefield Combat Identification System (BCIS) is a point-to-point, question and answer system intended to reduce fratricide in the forward battle area. BCIS is an added tool that is intended to increase the gunner's situational awareness and survivability of friendly forces in the battlespace.

The potential for fratricide will continue to be a problem with the advent of new weapon technologies enabling target engagements beyond visual identification range. BCIS is intended to allow the platform gunner or commander to identify friendly BCIS equipped platforms on the battlefield.

Initial versions of the system will go on Abrams Tanks and Bradley Fighting Vehicles. Subsequent versions will equip all vehicles—shooters and non-shooters—in this area. Future versions of the system are under development for dismounted soldiers and for air-to-ground and ground-to-air applications.

BCIS employs a millimeter wave beam to interrogate a potential target prior to firing. The BCIS interrogator is bore-sighted with the weapons sights, and an interrogation is conducted at the gunner's station. When an interrogation is received at the target vehicle, a BCIS transponder automatically responds with a friendly identification message. BCIS correlates the responding signal with the intended target's position using azimuth and range calculations from the system's laser range finder. BCIS provides audio tones and visual signals to the gunner to identify potential targets as Friend, Friend-at-Range, or Unknown.

### **BACKGROUND INFORMATION**

Army requirements for a combat identification system are documented in the Joint Mission Need Statement for Combat Identification, validated by JROC in March 1992. The Milestone I/II decision on July 25, 1993 approved the BCIS to enter into the engineering and manufacturing phase. Because of funding constraints, the system was returned to the technical base in 1995 and participated in several demonstrations and small tests.

A Limited User Test for BCIS was conducted in fall 1995 at Fort Hunter Liggett, CA. The results revealed that the number of fratricides with BCIS was substantially less than with the baseline

unit without BCIS. However, BCIS did not meet the system requirement of 90 percent correct identifications.

In 1997, BCIS was selected as one of the systems to be examined as part of the Joint Combat Identification Advanced Concept Technology Demonstration (ACTD). Systems showing promise during the ACTD were recommended for further development. In the ACTD final report of June 1999, BCIS was the only system recommended for entry into LRIP.

In June 1999, the Army approved a three-phased approach to field approximately 1,200 systems to the 4<sup>th</sup> Infantry Division at Fort Hood, TX. Phases I & II were initially funded for a total of 124 units. On February 20, 2001, the Army Acquisition Executive approved Phase III for production of the remaining LRIP units.

The current development strategy is to conduct two IOT&Es (IOT&E-1 and IOT&E-2 in FY01 and FY03, respectively), leading to an Milestone III in FY03. IOT&E-I was a Table VIII gunnery exercise against pop-up targets on a gunnery firing range. IOT&E-2 is to be a force-on-force exercise employing company-sized units. Following IOT&E-2, the system is intended to enter full-rate production to produce approximately 16,000 units to equip all active Army armored units.

### **TEST AND EVALUATION ACTIVITY**

The BCIS program manager conducted several tests to gain confidence that the system was ready to proceed to IOT&E-1. In the System Confidence Demonstration held in fall 2000, the BCIS-equipped M1A1 tanks and Bradley's met the system requirement of 90 percent correct identification. However, they performed no better than similar units not equipped with BCIS, as both baseline and BCIS equipped units had very low fratricide rates.

In the Virtual Integration Exercise conducted in fall 2000, BCIS was effective in reducing fratricide in night battles. However in day battles, more fratricides occurred than did at night. This phenomenon is believed to be the result of troops using BCIS at night when visibility is poor, but trusting their own vision in the day more than they trust BCIS responses.

BCIS participated in IOT&E-1 at Fort Hood in September 2001. Approximately 4,000 target silhouettes were engaged on a gunnery range. BCIS demonstrated the potential to improve target identification and reduce fratricide. However, units equipped with BCIS engaged significantly fewer friendly silhouette targets than non-BCIS units. While only a few hardware failures were reported, the low level of utilization (fewer than 500 total operating hours) resulted in a demonstrated mean time between failures significantly lower than the 1,200-hour requirement.

### **TEST AND EVALUATION ASSESSMENT**

In operational testing, BCIS has yet to demonstrate conclusively that it will reduce fratricide. Under operational conditions, crew behavior has resulted in limited demonstrated operational effectiveness to date. In some of the early operationally oriented testing, crews with BCIS have performed no better than crews without it. In other testing, crews performed well with BCIS at night, but poorer with BCIS during the day.

During recent IOT&E, units equipped with BCIS engaged significantly fewer friendly silhouette targets than non-BCIS units. However, there were severe limitations with this gunnery exercise that preclude projecting these observations to operational environments. First, there was only one BCIS equipped vehicle on the range at a time. This prevented exploring C3I and situational awareness issues that contribute to fratricide. The LRIP system tested did not provide for interoperability or compatibility with situational awareness systems such as the Force XXI Battle Command, Brigade and Below, or other systems designated within the overall Combat Identification Architecture. Interoperability with these other systems requires Block II improvements to BCIS, which will be completed in the out years.

Secondly, the IOT&E-1 gunnery exercise did not provide confusing or stressful situations for the crews, which they would experience in force-on-force battles when an opponent is engaging the friendly force. Crews commented that IOT&E was not very stressful. An exercise, in which an opponent is attempting to engage the friendly force and involves multiple friendly players on the battlefield at once, is required to adequately address BCIS' contribution to fratricide reduction.

In technical testing to date, the BCIS system has high reliability in laboratory testing and contractor testing, as well as robustness in the presence of jamming. IOT&E-1 produced only a limited suitability assessment. The BCIS equipped vehicles were each on the firing range for only a total of 2-3 hours. This is clearly not adequate to produce a suitability assessment that normally requires a system to complete its prescribed operational mission profile.

A full operational assessment of BCIS to overcome these limitations is planned for IOT&E-2 in FY03. This is expected to be a company-level, force-on-force exercise. The test will explore issues of Command, Control, Communications, Computers, Intelligence, Surveillance, and Reconnaissance created by having multiple vehicles in the battle simultaneously, and situations of stress and confusion created by employing a live opposing force. Additionally, vehicles will be subjected to a more realistic operational profile for the suitability assessment.

This Page Is Intentionally Left Blank

## **BRADLEY FIGHTING VEHICLE SYSTEM-A3 (BFVS-A3)**



The M2A3 and M3A3 Bradley Fighting Vehicle System (BFVS) are improved versions of the M2A2 and M3A2 BFVS. The BFVS-A3 includes enhancements intended to improve lethality, mobility, survivability, and sustainability. Additionally, these enhancements provide increased situational awareness and digital command and control capabilities.

The mission of the BFVS is to provide mobile protected transport of an infantry squad to critical points on the battlefield and perform cavalry scout missions. The BFVS will also provide overwatching fires to support dismounted infantry and suppress or defeat enemy tanks and other fighting vehicles. BFVS-A3 enhancements include:

- Force XXI Battle Command, Brigade and Below (FBCB2) Integrated Combat Command and Control (IC3) to share digital battle command information and situational awareness with all components of the combined arms team.
- The improved Bradley acquisition system and commander's independent viewer, both 2<sup>nd</sup> generation Forward Looking Infrared (FLIRs), to enhance target acquisition and target engagement.
- A position navigation system with a Global Positioning System receiver and a backup inertial navigation system to enhance situational awareness.
- Integrated maintenance diagnostics and Built-In-Test/Built-In-Test Equipment.

### **BACKGROUND INFORMATION**

In March 1994, the Army began the EMD phase. Previous operational testing conducted prior to FY01 included a Limited User Test (LUT) I in December 1997, an Operational Experiment in September 1998, a Detection, Acquisition, Recognition, Identification (DARI) test in October 1998, and a LUT II in August-September 1999.

The evaluation of the M2A3 vulnerability was based on the full-up, system-level live fire test (FUSL LFT), early M2A3 ballistic shock testing, electronic fault insertion events (controlled damage tests), directed energy weapon (laser) testing, and other sub-system or component T&E, as well as

previous M2A2 Live Fire T&E. The culminating LFT&E event was the FUSL LFT, conducted during the period December 1998-September 1999.

### **TEST & EVALUATION ACTIVITY**

BFVS-A3 IOT&E was conducted in October-November 2000 IAW a DOT&E approved plan. DOT&E monitored test events and conducted an independent assessment of the test and provided an Operational and Live Fire Test and Evaluation Report to the Secretary of Defense and Congress in April 2001. Planning for possible post-Milestone III vulnerability testing is currently ongoing. Such testing could include exploring fixes to unexpected vulnerabilities revealed in the LFT&E, or shock vulnerabilities of FBCB2 components.

### **TEST & EVALUATION ASSESSMENT**

M2A3 is operationally effective, suitable, and survivable. This assessment is based on the results of IOT&E, LUT-2, and the DARI. Overall, the M2A3 showed an improved level of operational effectiveness in comparison to the M2A2 Operation Desert Storm (ODS), the most advanced currently fielded version of the Bradley Fighting Vehicle System. This improvement in operational effectiveness is attributable to the M2A3's superior capability compared to the M2A2 ODS to detect, identify, and hit targets and the M2A3's improved night fighting capability. However, FBCB2 digital command and control, as integrated into the M2A3, demonstrated during IOT&E that it was neither effective nor suitable and it did not contribute to the operational effectiveness of the M2A3/M1A2 SEP equipped force. Despite this fact, M2A3 was able to demonstrate an overall improved level of operational effectiveness in comparison to the M2A2 ODS, predominately because of the capabilities of the M2A3's 2<sup>nd</sup> Generation FLIR and improved fire control system.

An FOT&E should focus on the operational effectiveness and suitability of the system's FBCB2 digital command and control capabilities. FOT&E will be conducted in conjunction with the FBCB2 IOT&E or FBCB2 LUT-III. Further details can be found in the Combined Operational Test & Evaluation and Live Fire Test & Evaluation Report on the M2A3 Bradley Fighting Vehicle System (BFVS) dated April 6,



## **CH-47F IMPROVED CARGO HELICOPTER (ICH)**



The CH-47F Improved Cargo Helicopter (ICH) is a remanufactured version of the combat proven CH-47D Chinook with the new T55-GA-714A engines. This Service Life Extension Program is intended to sustain the aging CH-47D airframes and extend the aircraft's life expectancy another 20 years. The CH-47D is a twin-turbine tandem rotor helicopter designed for combat and combat support heavy-lift cargo missions. ICH improvements include: (1) fuselage stiffening (proven through testing to reduce vibrations by up to 60 percent in the cockpit area and is expected to lead to improved reliability and reduced operating and support costs); and (2) integrated cockpit and digital architecture for Force XXI compatibility. The ICH program will rebuild 300 systems.

### **BACKGROUND INFORMATION**

OSD approved entry into EMD in 3QFY98. The current TEMP was approved on November 6, 1998. Another TEMP update is currently being staffed and should be submitted for OSD approval in early FY02.

Preliminary and Critical Design Reviews are complete. Because of cost increases and schedule delays, the program manager has recently restructured the program by delaying the LRIP and production decisions one year. IOT&E has been delayed by three months and is now scheduled for 4QFY02. It will provide input to the LRIP decision as well as Milestone III, now scheduled for 1QFY03 and 1QFY05, respectively.

DOT&E approved an alternative LFT&E plan after concurring with the Army's request for a waiver from full-up, system-level testing in December 1997. The waiver certification to Congress was provided by USD (A&T) in March 1998. A LFT&E Strategy was approved by the U.S. Army in December 1998 and by DOT&E in January 1999. A damaged CH-47D production aircraft was repaired and is being used as the LFT full-up, system-level ground test vehicle (GTV). The LFT&E started in 2QFY99.

### **TEST & EVALUATION ACTIVITY**

Initial testing of ICH software (version 4 of 5 planned versions) began in May 2001 in the Boeing System Integration Laboratory (SIL) in Philadelphia. While no priority 1 or 2 Software Trouble

Reports (STRs) resulted, 166 lower priority STRs were recorded. Operational pilots, as well as other government representatives, participated in SIL testing. Version 4 software continues to be tested in the aircraft by a combined team of government and contractor personnel. A weekly Software Review Board (SRB) examines the software Problem Reports and makes a determination as to their disposition. The SRB is composed of operational pilots, representatives from the U.S. Army Aviation Technical Test Center, the Program Management Office, and contractors. Version 5 of the software began SIL testing in October 2001.

Developmental flight testing began with an on-time first flight of the first EMD aircraft in June 2001. As of the end of FY01, shakeout flight testing, light gross weight strain and vibration flights, and medium gross weight vibration flights are complete. Medium gross weight strain flights are in progress. After the initial shakeout flights by Boeing Flight Test Pilots, Army Test Pilots have flown tests as per the Army approved test plans. Integrated contractor and government tests this fall and winter will include software, vibration, performance, and electronic environmental effects (E3) testing. The second EMD aircraft's first flight occurred in November 2001. It completed flight tests and was positioned as the primary aircraft to conduct E3 testing in November 2001. It appears that the EMD schedule is sufficient to complete all required developmental flight testing prior to operational testing scheduled for July 2002.

The LFT&E program has prepared event design plans for testing and for modeling and simulation and detailed test plans that describe the testing for the Cockpit Skin Panels, Cockpit Components, Fuel Sub-system, Propulsion System, and Engine Nacelle Fire Suppression System. Planning for the Fuselage Tunnel Flight Controls System will start in FY02. The initial M&S for the baseline CH-47D and the CH-47F ICH is in progress and will be updated at the conclusion of LFT.

The program initiated ballistic testing of the Cockpit Skin Panels in 3QFY99 and completed 183 shots. Testing of the T55 engine and fuel sub-system began in 2QFY00. Cockpit components and fire suppression system began testing in 1QFY02.

Testing of the T55 engine and the fuel sub-system included both controlled damage dynamic simulations (with engines and rotors running) on the CH-47D GTV, and ballistic tests on actual production or surrogate components. During the tests, test events were conducted on various fuel-plumbing components and fuel tanks by simulating operational fuel flow conditions. For the propulsion system, controlled damage tests were completed on the GTV, and ballistic tests on various static (non-rotating) components of older but very similar T-55 engines. Ballistic testing of dynamic (rotating) engines will start in FY02.

In addition, as part of the DOT&E Joint Live Fire (JLF) program, 10 ballistic tests for the CH-47D rotor blades have been performed. Since these blades are the same as those to be used on the F-model, the data derived from the JLF program is directly applicable to the LFT&E of the CH-47F.

## **TEST & EVALUATION ASSESSMENT**

The CH-47 is a proven and dependable platform. With 130 flight hours of developmental testing, 90 flight hours of operational testing and a continuing R&M data collection effort, post Initial Operational Test, of 280 flight hour duration prior to milestone (MS) III, the proposed integrated test for this Service Life Extension Program should provide sufficient data to support a preliminary assessment of the operational effectiveness and suitability of the CH-47F. However, there are areas of concern.

The Army acknowledges that there is increased statistical risk stemming from the low number of flight hours planned for IOT&E. However, in view of the fact that this program is actually a remanufacturing of an already proven aircraft, and not a newly developed system, we anticipate that the risk of demonstrating R&M requirements before MS III is low. An additional 300 hours, planned to be flown during the training and fielding of the first unit equipped, brings the total test hours flown to 800 to complete the evaluation. This follow-on R&M data collection of 300 hours will not be completed in time to support the MS III decision, but is critical to demonstrating the anticipated reliability and maintainability improvements.

Software testing in the SIL may lack sufficient rigor to discover or properly score software errors. To date, test procedures in the SIL have focused on individual cockpit systems in a laboratory mock-up without the stresses of realistic operations. Communication nets were physically connected; there were no environmental extremes, no dust, no rain, no competing electromagnetic emissions, and no aircraft vibrations. In a benign environment, significant software anomalies that can affect operational performance may go unnoticed. For this reason, maturity of version 4 software will be confirmed during aircraft developmental and operational flight testing.

The CH-47F LFT&E program is a fairly robust program. Ample test data from the Army's LFT of the CH-47F and the DOT&E Joint Live Fire program of the basic CH-47D are expected to provide a good evaluation of the CH-47F. The only LFT&E concern at this time is that, at the completion of LFT, GTV may not be viable for the dynamic testing of the main rotor blades.

This Page Is Intentionally Left Blank

## CHEMICAL DEMILITARIZATION PROGRAM



The Chemical Demilitarization Program is an Army managed program responsible for the destruction of the U.S. stockpile of lethal chemical agents and munitions. This program is required to comply with the Chemical Weapons Convention (CWC), which is a major arms control and nonproliferation treaty that entered-into-force on April 29, 1997.

The Chemical Stockpile Disposal Project is responsible for destruction of the U.S. stockpile of unitary chemical weapons. Nine chemical agent disposal facilities are or will be collocated with nine chemical depots. Five disposal facilities are employing the baseline chemical weapons disassembly and incineration process. The Alternative Technology and Approaches Project is responsible for conducting pilot testing of alternative (to incineration) destruction technologies. The Army has selected chemical neutralization of agent followed by post-treatment of the neutralized products for the bulk storage disposal facilities being constructed at Aberdeen Proving Ground, MD, and at the Newport Chemical Depot, IN. At the direction of Congress, the Assembled Chemical Weapons Assessment Program was established in 1996 to evaluate alternative technologies for the Pueblo and Blue Grass disposal facilities. Selection of the final destruction technologies are awaiting the Records of Decision from the Environmental Impact Statement process for those sites. Technology decisions are planned for January 2002 and July 2002, respectively.

- Incineration disposal facilities:
  1. Johnston Atoll Chemical Agent Disposal System: disposal complete, in closure.
  2. Tooele Chemical Agent Disposal Facility, Deseret Chemical Depot (UT): operational.
  3. Anniston Chemical Agent Disposal Facility (AL): construction complete, in test.
  4. Umatilla Chemical Agent Disposal Facility (OR): construction complete, in test.
  5. Pine Bluff Chemical Agent Disposal Facility (AR): under construction.
- Neutralization disposal facilities:
  6. Aberdeen Chemical Agent Disposal Facility (MD): under construction.
  7. Newport Chemical Agent Disposal Facility (IN): under construction.
- Disposal technologies still to be determined:
  8. Pueblo Chemical Agent Disposal Facility (CO).
  9. Blue Grass Chemical Agent Disposal Facility (KY).

The Non-Stockpile Chemical Materiel Project (NSCMP) is responsible for the destruction of non-stockpile chemical warfare materiel, including the components of binary chemical weapons, miscellaneous chemical warfare materiel, recovered chemical weapons, former production facilities, and buried chemical warfare materiel. The NSCMP developed and tested several mobile systems: (1) the Explosive Destruction System (EDS); (2) the Rapid Response System (RRS); (3) the Mobile Munitions Assessment System (MMAS); and (4) the Portable CAIS (Chemical Agent Identification Set) Assessment System (PCAS). Two additional variants of EDS are in development. Two non-stockpile disposal fixed facilities are planned: (1) the Munitions Assessment and Processing System (under construction) at Aberdeen Proving Ground, MD; and (2) the Pine Bluff Non-Stockpile Facility at Pine Bluff Arsenal, AR.

## **BACKGROUND INFORMATION**

As a result of CWC entry-into-force, destruction of 100 percent of the stockpile of unitary chemical weapons is required by April 29, 2007, unless the signatories to the CWC approve a five-year extension. As of August 19, 2001, the Johnston Atoll and Tooele facilities had successfully destroyed approximately 23 percent of the total U.S. chemical weapons stockpile (originally 31,496 agent tons). The Army has met the first two milestones of the CWC (1 percent and 20 percent destruction, respectively).

The Johnston Atoll disposal facility completed chemical agent operations in November 2000, and is currently in the closure process. The Tooele disposal facility is currently the only operational facility. The Anniston and Umatilla disposal facilities are planned to begin agent operations in mid-CY02.

The disposal facilities are government owned and contractor operated. Each site's prime contractor conducts all developmental and operational testing under oversight of the Program Office and the U.S. Army Materiel Systems Analysis Activity (AMSAA). The Chemical Demilitarization Program was placed under OSD oversight in December 1994. Since then, DOT&E has provided oversight of the stockpile, non-stockpile, and alternate technologies projects within the Chemical Demilitarization Program.

## **TEST & EVALUATION ACTIVITY**

The Anniston and Umatilla disposal facilities completed construction in June and August 2001, respectively. During construction, testing consisted of contractor-conducted component and sub-system checkout. DOT&E conducted walk-throughs of each facility and participated in on-site meetings with the Program Office, AMSAA, and the prime contractor to determine readiness to begin system developmental testing, which integrates the sub-systems for an end-to-end test with surrogate chemical agent. DOT&E supported recommendations to begin developmental testing activities at each site, which are currently in progress. DOT&E will continue to monitor the developmental test activity and independently analyze selected portions of the test data, leading to a determination of readiness to begin operational testing with active agent in CY02. The Pine Bluff, Aberdeen, and Newport disposal facilities are still under construction. Test activities in FY01 at those sites consisted of limited component and sub-system checkout. DOT&E participated with the Program Office and AMSAA through the Test Integrated Process Team to monitor progress and continue test planning for those facilities.

DOT&E reviewed and approved the TEMPs for the Umatilla, Aberdeen, and Newport facilities, and provided comments on the draft Pine Bluff TEMP, which is in development. DOT&E previously approved the Anniston TEMP in 2000.

DOT&E provided selective on-site monitoring of multiple non-stockpile test activities throughout FY01. DOT&E observed operational testing for the RRS and the PCAS, and independently assessed the test results. DOT&E actively participated in the Operational Readiness In-Process Reviews for these systems and supported the Program Manager's decision to declare both systems operational in FY01, along with the MMAS, which completed operational testing in FY00. The RRS was subsequently used to successfully dispose of the CAIS inventory contained in overpacks at Deseret Chemical Depot.

After completing successful developmental testing at Porton Downs, UK, which DOT&E observed, the prototype EDS was returned to Aberdeen Proving Ground to begin operational testing with nerve agent, mustard, and phosgene. Operational testing was temporarily suspended twice, in December 2000 and June 2001, respectively, in order to relocate the prototype EDS to the Rocky Mountain Arsenal in Denver, CO, where it was used successfully to destroy a total of ten recovered M139 GB nerve agent bomblets. DOT&E supported an Army decision to use the EDS prototype since developmental testing at Porton Downs had been conducted with live chemical agent, and independent analysis of the test data revealed that using the EDS prototype for emergency disposal operations could be done at acceptable and moderate risk. DOT&E observed this disposal activity and analyzed the data, which supplemented the operational test effort. EDS operational testing with mustard and phosgene resumed in September and was completed on October 2, 2001. DOT&E also participated in the test planning for future variants of EDS.

DOT&E reviewed and provided comments to the Program Office for a revision to the Non-Stockpile Overarching Test Concept Plan, which is a TEMP-like document covering test planning for all non-stockpile programs. DOT&E also reviewed individual test plans for each of the non-stockpile systems.

### **TEST & EVALUATION ASSESSMENT**

U.S. Army testing of stockpile and non-stockpile systems in the Chemical Demilitarization Program has been adequate to ensure the safe and efficient disposal of the inventory of chemical warfare materiel. Operational testing of EDS-1, RRS, MMAS, and PCAS has demonstrated that these systems are operationally effective and suitable.

The U.S. Army Materiel Systems Analysis Activity is providing effective independent oversight of the testing of both stockpile and non-stockpile programs.

This Page Is Intentionally Left Blank



## COMANCHE (RAH-66)



The RAH-66 Comanche is a twin-engine, two-pilot stealthy armed reconnaissance/attack helicopter which features low observable composite technologies with retractable landing gear and weapons pylon to achieve a low Radar Cross-Section (RCS) and a unique heat management system to suppress its infrared signature. A five-bladed main rotor and a shrouded tail rotor minimize the acoustic signature. A fly-by-wire flight control system and fully integrated digital avionics assist in piloting the aircraft. The Mission Equipment Package (MEP) integrates a radar, a forward-looking infrared sensor, and an image-intensified television sensor for night flying and target acquisition. The Comanche will be armed with the Hellfire missile, an air-to-air missile, 2.75-inch aerial rockets, and a turreted 20mm gun. The Comanche will replace the AH-1 and OH-58 helicopters in attack and cavalry units and some AH-64 Apaches in heavy attack units.

### **BACKGROUND INFORMATION**

The development of the Comanche helicopter began in 1983 as the Light Helicopter Experimental (LHX). In the early 1980s, the LHX was envisioned to be a family of lightweight helicopters that could come in a scout, utility, or attack version. In 1988, the Army decided on a single combined armed reconnaissance and attack version.

The Milestone (MS) I Acquisition Decision Memorandum (1988) and TEMP envisioned an operational evaluation of an integrated system before MS II. However, program development was restructured and delayed several times, primarily as a result of several funding reductions until Comanche funding was partially restored in FY99. Even though developmental activities were delayed, the target date for MS III was not slipped, thereby compressing the schedule to force concurrent developmental testing, training, and operational testing in the two years prior to MS III.

First flight of the Comanche prototype occurred in January 1996. The current schedule has the first of 13 EMD aircraft to be delivered in April 2004. A fully integrated aircraft is not scheduled to be available until FY05. An updated TEMP was approved by OSD in February 2000. Both MS II and the program's entrance into EMD occurred in April 2000. MS III and Initial Operational Capability are scheduled for December 2006.

The Comanche program was designated a LFT&E system in November 1989. The LFT&E strategy was approved in fall 1995 and was recently revised as part of the updated TEMP in February 2000.

### **TEST & EVALUATION ACTIVITY**

Testing to date has focused largely on sub-systems, flight testing of various configurations of the two prototype aircraft with no MEP, RCS testing of a full-scale model, component-level contractor testing, and two crew-level simulation events.

LFT&E activities since the MS II included the completion of the initial vulnerability assessment, and a series of risk reduction ballistic and structural tests on evolving design configurations for the main rotor blade, lightweight crew armor, and several FANTAIL (the newly developed enclosed anti-torque system) components against various caliber threats. The driver for the redesign of these components is to reduce weight and cost. The ballistic effort also involves a validation/verification type effort for the finite element analysis model for evaluating the dynamic structural response of the various FANTAIL structural components when impacted by high explosive incendiary projectiles.

Other LFT&E activities involved the 20mm ammunition and engine nacelle fire suppression system. The first effort involved the selection of a supplier for the XM1031 improved 20mm ammunition and the test planning to determine the penetration characteristics of the projectile. In a related effort, the first gun barrel is in gun contractor testing. The fire suppression effort involves finding an alternative agent to halon; testing of the down-selected candidate agents is scheduled to begin in FY02.

### **TEST & EVALUATION ASSESSMENT**

As stated in last year's report, DOT&E's position remains that it is unlikely that the Service can deliver the expected system performance within the current budget and schedule.

**Weight Growth.** The program has reported that it will not achieve the MS II weight goal of 9,300 pounds and has set a new production weight goal of 9,400 pounds. To compensate for the weight growth, the PM has decided to increase the core temperature of the engines to produce an additional 70 shaft-horsepower for each engine. Testing to determine if the increased operating temperatures will reduce engine life is ongoing. The increased engine power and weight goal gives the PM about a 2 percent margin of weight growth during the remainder of EMD. Since most aircraft programs experience weight growth in excess of 2 percent during EMD, there is some risk that certain range or vertical rate of climb performance requirements may not be met by MS III.

**Flight Testing.** Flight testing of the two prototype aircraft has resulted in steady progress, but each design change has introduced new problems. Flight testing prior to MS II revealed a noticeable tail buffet as the aircraft's speed reached 80 to 100 knots. A reshaped pylon, first flight tested in 1999, reduced tail buffeting but compromised directional stability. To restore directional stability, endplates were added to a slightly shorter tail. Flight testing of the redesigned tail has confirmed that directional stability has been restored to acceptable levels with and without the radar dome installed. Full scale testing has also confirmed that the 5-foot<sup>2</sup> endplates do not significantly impact RCS. However, the endplates have created new challenges for antenna placement and possibly performance.

**Comanche Radar.** A redesign of the Comanche radar (CR) antenna in the past year has increased schedule risk, but may have reduced the risk to performance. At MS II, the CR design hinged on an electronically steered array (ESA) antenna that was thought to be crucial to meeting performance requirements. The prototype ESA antenna, however, exhibited excessive losses during MS II testing and has since been abandoned in favor of an Azimuth and Elevation Mono-Pulse mechanically scanned antenna, building upon the success of the Longbow Fire Control Radar development. Additionally, designers believe that the Azimuth and Elevation Mono-Pulse mechanically scanned antenna will eliminate the need for roll-stabilizing the antenna azimuth mount, reduce weight, increase reliability, reduce O&S costs, and support synchronous scanning and fusion with the electro-optical sensor suite.

Unfortunately, the schedule for the development of a flight-ready engineering model for the CR has been shortened by the antenna redesign. It is critical that a working model of this antenna be available as soon as possible to permit the airborne collection of clutter data and development of the CR detection algorithms. Confirmation of the efficacy of the proposed antenna concept is scheduled for October 2002 and hinges on the collection of radar performance data against moving and stationary targets. The schedule for integration of the CR onto the aircraft is equally compressed. The earliest date for installation of the CR on Comanche aircraft #2 is October 2003. A short 22-month window, to address product shortfalls if necessary, follows the installation of the first prototype antenna before IOT&E.

**Radar Cross-Section.** From a preliminary review of RCS measurements of a full-scale model, the Comanche appears to be in a position to meet RCS goals in most areas. It is particularly encouraging that there was margin between measured RCS averages and ORD requirements at many of the frequencies. RCS will only grow from these measurements, as sensors are added and as additional, inevitable aircraft modifications are made to solve problems unrelated to signature.

**Maintainability of Low Observable (LO) Materials.** Sustained operational success for the Comanche will depend heavily on the reliability and maintainability of LO aircraft components. The program office discovered that curing times for LO materials exceed the required maintenance thresholds. Procedures for maintenance of LO materials are being developed to reduce curing times in order to achieve sustainability requirements.

**Antennas.** Antenna placement, design, and performance are one of the highest program risk areas. Fewer than half the planned avionics antennas have been installed on the full-scale model and many remain to be designed and integrated. The focus to date seems to have been on maximizing antenna gain while minimizing radar signature. While gain is certainly a critical parameter that must be addressed, pattern coverage may prove to be the more intractable problem. Attempts to meet the RCS budget may compromise antenna performance to the point that it adversely affects operational effectiveness. Consequently, testing of antenna patterns and gain measurements should be made as soon as practical so that problems can be identified and addressed early.

**MEP Integration.** Overall, the Comanche has a high-risk test and evaluation strategy for integrating the MEP components on the aircraft. Integration and testing of the complete MEP on the aircraft will not occur until the end of the EMD phase. The resulting schedule compression allows little reserve in the timetable, thereby increasing the impact of unforeseen events/delays and leaving no time to resolve problems discovered in testing.

**Comanche Reliability.** Although the program office/contractor has a comprehensive system to identify and correct failures, corrective actions generally will not be implemented except at several discrete points in time. Because of the compressed developmental schedule, it will be difficult to demonstrate improvements in aircraft reliability by means of testing. Moreover, the program office has recently proposed later deliveries of EMD aircraft and reductions in the number of EMD flight hours. Consequently, it is even less likely that Comanche will demonstrate the required levels of reliability before MS III.

**Crew Station Simulations.** In the past year, two simulation events have refined Comanche tactics, techniques, and procedures and confirmed that design of the Comanche cockpit will facilitate mission accomplishment. There has been steady progress in the maturity of software supporting the cockpit simulators. Scenario, threat, and task realism have improved significantly. While the simulators still lack fidelity in several key areas (engagements are not resolved realistically and the tactical internet is not portrayed) the program is postured to successfully conduct the operational test event, Force Development, Test and Experimentation I in FY02.

The LFT&E program, scheduled to be completed before MS III, includes component qualification and sub-system level ballistic testing for 27 critical components, as well as full-up, system level dynamic testing on a production-representative configuration aircraft. However, because of the compressed nature of the EMD phase (aircraft # 11 designated for LFT&E is scheduled to be delivered in May 2005), it will be extremely difficult to correct any weaknesses discovered during LFT&E. There is a schedule risk to accomplish the stated goals of the ORD.

Because of cost growth and schedule delays since EMD, the Army has recognized that a new Comanche development strategy is needed. The Army intends to develop a revised strategy by 2QFY02. It is envisioned that the revised development strategy will be an evolutionary approach to deliver the ultimate capability to the user via block developments, with increasing increments of capability.

Comanche is a revolutionary helicopter design. It is imperative that the revised development strategy, now being considered by the Army, eliminates the concurrency between the development of the aircraft and testing. This is critical to providing the much needed time to identify problem areas, which are bound to arise in testing and to develop and apply fixes to the system prior to initial operating capability.

## **CRUSADER HOWITZER AND RESUPPLY VEHICLE**



The Crusader system is the Army's next-generation, 155mm, Self-Propelled Howitzer (SPH) and its companion re-supply vehicle, either tracked (RSV-T) or wheeled (RSV-W). Crusader will be the indirect fire support system for armored and mechanized forces of the U.S. Army's Counterattack Corps.

The Crusader SPH will employ Advanced Solid Propellant Armament using a modular propellant charge system, auto-settable multi-option fuze, automated ammunition handling, Global Positioning System (GPS)-based position location and azimuth reference system, with improved mobility, reliability, and maintainability. The SPH is designed to deliver unassisted munitions at ranges to 30 kilometers and assisted munitions to 40 kilometers, provide a maximum rate of fire of 10 to 12 rounds per minute for 3 to 5 minutes, and provide a sustained rate of fire of 3 to 6 rounds per minute. It is required to have the agility and mobility to keep up with the supported maneuver force of M1 Abrams tanks and M2 Bradley fighting vehicles. It must be able to complete a survivability move of 750 meters within 90 seconds of identifying a potential threat. There will be an equal mix of RSV-Ts and RSV-Ws with automated ammunition and fuel re-supply functions and GPS-based navigation systems. The SPH and RSV-T will each have a crew of three to replace the four and five crewmen, respectively, currently on the Paladin and the M992A1 Field Artillery Ammunition Support Vehicle. The RSV-W will have a two-man crew.

### **BACKGROUND INFORMATION**

The Crusader SPH and RSV program, formerly the Advanced Field Artillery System and Future Ammunition Re-supply Vehicle, began in 1992. Crusader Operational Requirements Documents were approved in June 1993. In November 1994, the program completed a successful Defense Acquisition Board Milestone I review and entered the Program Definition and Risk Reduction phase. In 1997, a decrement in program funding caused a revision to the Acquisition Program Baseline and a slip of the Milestone B review. The Milestone B decision is now scheduled for April 2003.

In 1QFY00, the program again restructured to address software development/integration problems, a funding reduction, and a change in the Army's priorities. Crusader re-entered the preliminary design phase to make it lighter (38 to 42 tons per vehicle), enabling both C-5s and C-17s to transport two SPHs without weight waivers. The program restructure added an RSV-W with an automated re-supply module mounted on a palletized load system carrier. Crusader has also joined the Abrams program in seeking a common engine. The Milestone B Review slipped to 3QFY03, with IOT&E and first unit equipped in 2008. In August 2000, DOT&E approved a Crusader TEMP. The approval memorandum requires a revised TEMP for Milestone B to update the LFT&E strategy, vehicle designs, and the power train development.

## **TEST & EVALUATION ACTIVITY**

Throughout 2001, the Self-Propelled Howitzer-1 Emulator (SPH1E) has been undergoing propellant handling and firing tests at Yuma Proving Ground, AZ. SPH1E includes the chassis, armament, and ammunition handling equipment hardware of a heavy Crusader prototype with emulation electronics and software. SPH1E achieved a 40-kilometer range and fired a ten-round mission at the maximum rate of fire.

United Defense, the prime contractor, has built test stands of heavy system armament and ammunition handling hardware to assist the development of software and assessment of hardware reliability. The test stands have already exceeded 25,000 test cycles. United Defense will soon integrate the test stands, crew stations, electronics, and tactical software into a Crusader Integrated Test Station (CITS). Build 3 of Release 3 of Crusader software has been completed and is ready for integration into CITS. CITS will be used to exercise fire missions (inert charges and rounds), re-supply, upload/download, and inventory management functions for both the SPH and RSV.

The Crusader program continued Vulnerability Reduction Measures (VRM) tests during FY01. Those activities included a Survivability Test Section experiment that simulated the effects of a propellant compartmentation ignition. The experiment provided engineering data to the designers of the SPH propellant bustle developing blow-off panels and compartment designs to protect the crew from fires and low-level explosions in the propellant stowage area. The VRM program is a key element of the LFT&E strategy and will serve as a significant data source for the vulnerability evaluation. The LFT&E Integrated Product Team has actively worked to develop a mature LFT&E strategy for incorporation in the TEMP at its next revision.

## **TEST & EVALUATION ASSESSMENT**

Test firings with the SPH1E have shown that the Crusader has the potential to meet its range and rate of fire requirements. However, technical problems have delayed SPH1E testing intended to demonstrate that Crusader can consistently achieve those requirements.

The TEMP includes an effective operational testing program that includes an early user experiment to support the Milestone B decision, a Limited User Test (LUT) to support a Milestone C decision, Force Development Test and Experimentation (FDT&E) to support development of tactics, techniques and procedures, and IOT&E to support the full-rate production decision. The LUT (FY05) and FDT&E (FY07) will allow soldiers to exercise Crusader prototypes under operational conditions, while the IOT&E (FY08) will put a battery of LRIP Crusaders through 96 hours of simulated combat.

The LFT&E plan is not yet completed for the redesigned system to replace the LFT&E assumptions in the current TEMP. Sufficient test assets must be programmed to assure adequate vulnerability characterization and crew survivability assessment. The plan must also identify simulation models that can be leveraged to maximize our understanding of Crusader vulnerability and fill-in test gaps. Assets must be allocated for verification, validation, and accreditation of those models.

Key areas of risk in development of the Crusader have been software development, tube cooling, tube life, and system reliability. Weight reduction initiatives have added parallel Abrams-Crusader Common Engine and drive train development, design margin of safety, and material properties of titanium, aluminum, and composite material components to the watch list. These initiatives increase the program's technical, cost, and schedule risk.

## **FORCE XXI BATTLE COMMAND, BRIGADE AND BELOW (FBCB2)**



Two important components of the Army's Battle Command System and the Battlefield Digitization effort are the Force XXI Battle Command, Brigade and Below (FBCB2) program and its supporting Tactical Internet. FBCB2 is a digital, battle command information system intended to provide commanders, leaders, and soldiers—from brigade to individual soldier, and across all the Battlefield Functional Areas—improved command and control and enhanced situational awareness information. FBCB2 primarily consists of software, but will also include a ruggedized computer for those users and platforms without an existing computer system. Systems with existing computers capable of hosting FBCB2 software will receive the Embedded Battle Command software—a sub-set of FBCB2—and additional hardware as necessary. Embedded systems for the near term include the M2A3 Bradley Fighting Vehicle, the M1A2 System Enhancement Program Tank, and the Army Tactical Command and Control Systems (ATCCS).

FBCB2's primary functions are to send and receive automatic position location reports derived from its interface with the Global Positioning System and to send and receive command and control message traffic via digital over-the-air radio transmissions. The Tactical Internet is the network of radios and routers that provide linkages to connect the myriad FBCB2 platforms (both vertically and horizontally) across the combined arms force. The Tactical Internet consists of the Enhanced Position Location Reporting System, the Single-Channel Ground and Airborne Radio System, and the Internet Controller router.

FBCB2 and the Tactical Internet perform as a network within brigade-sized and smaller units. At the brigade and battalion Tactical Operations Centers (TOCs), the Tactical Internet interfaces with ATCCS, an Ethernet-based local area network of computers representing the functional areas of intelligence, maneuver, air defense, combat service support, and fire support. This interface permits information collected and disseminated via ATCCS systems to be rapidly passed through the Tactical Internet to FBCB2 computers. Likewise, the position reports of individual and unit locations are passed upwards through the FBCB2 and Tactical Internet into the ATCCS system for dissemination throughout the force. Network initialization and management requirements are performed by the Tactical Internet Management System that resides at the brigade TOC.

### **BACKGROUND INFORMATION**

The Army initiated the Force XXI Battlefield Digitization program in 1994, with the intent to proliferate and integrate digital communications and information management technologies across the

combined arms spectrum. The Army's efforts have been demonstrated in a series of Advanced Warfighting Experiments (AWEs). The Task Force XXI AWE equipped a brigade from the 4th Infantry Division with FBCB2 (Appliqué) hardware and software on all of its 1,600-plus vehicles. Due to immaturity of the FBCB2 and Tactical Internet, the degree of digital connectivity achieved during the Task Force XXI AWE was not sufficient to achieve expected increases in lethality, survivability, and op tempo and was not suitable for tactical operations.

A Limited User Test (LUT)-1 was conducted at Ft. Hood in FY98 with a Battalion Task Force of 232 platforms equipped with FBCB2. The FBCB2 software lacked several critical capabilities called for in the ORD and experienced many heat-related failures. Nonetheless, FBCB2 system performance during LUT-1 represented a significant improvement over that observed during the Task Force XXI AWE. The friendly situational awareness information provided by FBCB2 and the new Tactical Internet architecture was generally accurate and timely, and the improved system stability permitted soldiers to employ FBCB2 information during the execution of their missions. A Reliability Demonstration Test (RDT) was conducted from June-July 1999 to demonstrate correction of heat-related hardware failures experienced during LUT-1. A large increase in the hardware reliability was observed, but a comparable demonstration during an OT is required to determine that the improved performance can be reproduced in the operational environment. It should also be noted that the RDT results did not factor in failures of non-FBCB2 equipment critical for FBCB2 to be effective.

In June 1999, the Army proposed a restructured FBCB2 Program with heavy emphasis on system-of-system digitization, and also on the role of the Army Battle Command System (ABCS). Under the revised architecture, FBCB2 hardware will not be present in Tactical Operations Centers. Situation awareness information will be processed by Embedded Battle Command software, and command and control functions (messages, orders, overlays, etc.) will be performed by ABCS software, both hosted on ATCCS workstations. Therefore, any testing that includes units above the company level must include ATCCS systems and requisite interoperability between FBCB2 and ABCS software. This requires FBCB2 spiral development to coincide with the spiral developments of other Battlefield Digitization programs, as determined by the requirements of the next capability package.

A combined LUT-2/Force Development Test and Experiment was scheduled for FY00 to examine performance and interoperability of FBCB2 and ABCS systems, as well as critical tactics, techniques, and procedures. As a result of immature ABCS software, the Army downgraded the LUT-2 to a Customer Test (CT) when it became clear that the LUT-2 entrance criteria could not be achieved. Although not technically an operational test, the CT was essentially the same test as LUT-2. ABCS functionality proved ineffective at developing and disseminating operational orders and overlays during CT, hindering the attainment of the Common Tactical Picture and prosecution of the maneuver battle.

## **TEST & EVALUATION ACTIVITY**

The Army conducted Field Test-3 in January 2001 at the Electronic Proving Ground, and this test was followed by a brigade-level LUT-2 in April 2001 at the National Training Center, in conjunction with the Army's Division Capstone Exercise. Although new functionality was demonstrated, network performance measures for FBCB2 messages were significantly reduced from prior tests, and the interoperability between FBCB2 and ABCS was ineffective. Based on these results, the Army decided to pursue a revised acquisition strategy where the links between FBCB2 and ABCS are severed for the threshold requirement. The FBCB2 ORD has been revised with new blocks, and is to be reviewed by the Joint Requirements Oversight Committee in late 1QFY02. Changes to the TEMP and Test Plans are also underway.



In September 2001, production-representative FBCB2 hardware and software were examined in Field Test-4 to determine their readiness for the FBCB2 IOT&E scheduled for December 2001. The IOTE entrance criteria were not met, and this event was downgraded to a LUT.

## **TEST AND EVALUATION ASSESSMENT**

Survey data from operational tests suggests that the employment of FBCB2 assists commanders in the control of maneuver and in the synchronization of combat power. Other observations indicate that situation awareness provided by FBCB2 permits commanders to focus more of their time on actually commanding, as less time is required to track positions and movement of their forces. These results highlight the potential of FBCB2; however, these anecdotes reflect the satisfaction of soldiers in FBCB2 when it works, and belie the inconsistent performance that has been observed to date. A number of critical enhancements are needed in order to achieve a reliable and operationally effective and suitable capability.

Specific concerns, or required enhancements, include the following:

- A network management capability that can perform required unit task reorganizations, monitor the network's health, and respond to identified problems has yet to be demonstrated.
- Interoperability with ABCS software is required in order to provide brigade-and-below capability. FBCB2-ABCS interoperability has not achieved the maturity required to perform basic command and control tasks.
- Network stability and system reliability are much lower than would be operationally suitable, and extensive contractor support has been required to achieve even these performance levels. System support plans have yet to be finalized, but drafts are at odds with Army policy that limits the number of contractors on the battlefield.
- Many operations/tasks require cumbersome workarounds that are time-consuming and invite mistakes. The soldier operators have often responded to this situation by not employing required capabilities, with resulting mission degradation.
- There have been high levels of fratricide in all digital events to date.
- Scalability, or the ability of the network communications to perform well with a large but operationally realistic number of nodes, remains a concern. Many unexpected problems surfaced during April 2001 LUT-2 testing with two brigades, and the proposed fixes have yet to be demonstrated in a large network.
- Operational testing conducted to date has been restricted to near-ideal conditions of EW/IW, weather, visibility, and terrain. Significant degradation in performance is expected as any of these conditions become more stressful. Furthermore, tactics, techniques, and procedures to support graceful degradation are immature. The Army proposes to defer OT in these environments until after Milestone III. Adequate testing in the above environments is required in order to determine how much degradation the systems can tolerate before becoming ineffective and the ability of soldier operators to recognize problems and execute the proper response.

This Page Is Intentionally Left Blank

# FORWARD AREA AIR DEFENSE COMMAND, CONTROL, COMMUNICATIONS, AND INTELLIGENCE (FAAD C3I) SYSTEM

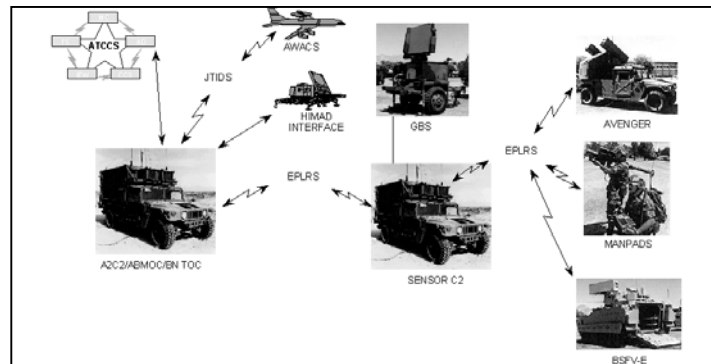

The Forward Area Air Defense Command, Control, Communications, and Intelligence (FAAD C3I) system is a network of components that connect command posts, weapons, and sensors of the Army's short-range air defense units. The Ground-Based Sensor (GBS), also called Sentinel, provides air surveillance, target acquisition, and target tracking information to the weapons in the FAAD Battalion. FAAD C3I is part of the Army Battle Command System. FAAD C3I consists of computer hardware, software and communications that provide command, control, targeting, and other information to air defenders on the battlefield, and provides a shared common air picture with the Air Force, Navy and the Patriot Missile System. FAAD C3I software performs air track and battle management processing functions and uses Single-Channel Ground and Airborne Radio System (SINCGARS), the Joint Tactical Information Distribution System (JTIDS), and the Enhanced Position Location Reporting System (EPLRS) for communications. The Sentinel TPQ-36A radar is a three-dimensional radar system using a phased-array antenna and an Identification Friend or Foe device. The GBS/Sentinel system is mounted on a High Mobility Multi-Purpose Wheeled Vehicle with a towed trailer.

## **BACKGROUND INFORMATION**

The FAAD C3I and GBS IOT&E, conducted in 1994, clearly showed FAAD C3I and GBS demonstrated improved effectiveness over the baseline when no friendly aircraft were flying. However, when friendly aircraft were added to the operational scenario, fratricide in both the baseline and FAAD C3I units was unacceptably high. This made FAAD C3I useful only when friendly aircraft were not present or as a self-defense system. Further analysis by the Army found that many of the fratricide problems involved leadership, training and soldier performance issues as opposed to technical performance. The FAAD C3I and GBS systems were judged to be operationally suitable, except for shortfalls in the generator, GBS software reliability, and mobility.

A new version of FAAD C3I software, version 4.R, re-hosted the FAAD C3I software on the Army's next-generation Common Hardware and Software-2 hardware. The reliability problems noted in IOT&E were fixed and successfully tested during the 1997 Performance Verification Test. This test revealed a design flaw in the high mobility trailer used to transport the GBS system. The Army identified an interim solution and a materiel release was issued in November 1998.

The latest FAAD C3I system is version 5.2. The most significant change is the re-hosting of FAAD C3I software on Force XXI Battle Command, Brigade and Below (FBCB2) hardware. Specifically, the FBCB2 V4 computer displays either the FAAD C3I air defense picture or the FBCB2 ground picture. This requires FAAD C3I to transmit data over the same tactical internet network of EPLRS radios used by the FBCB2 V4 computer. The FBCB2 V4 computer also replaces the FAAD handheld terminal unit.

## **TEST & EVALUATION ACTIVITY**

There was no formal operational testing of the FAAD C3I system during FY01. The Army conducted a System Certification Test during 3-4QFY01 in preparation for the Limited User Test (LUT) of FAAD C3I version 5.2 to be held in conjunction with the Patriot PAC-3 IOT&E, March 2002.

The Army Operational Test and Evaluation Command (ATEC) published an Interim System Assessment for the FAAD C3I System Block III software version 5.2 in October 2000. This assessment was based on FAAD participation in two FBCB2 test events – Field Test 2 (December 1999-March 2000) and the Customer Test (April 2000). These events constituted Phase I of the FAAD C3I version 5.2 System Assessment.

In FY01, the FAAD C3I system participated in the Army's Joint Contingency Force Advanced Warfighting Experiment, Division Capstone Exercise at Fort Irwin, California, and to a limited degree in the FBCB2 Field Test 4 at Fort Huachuca, Arizona. The Division Capstone Exercise, Phase I, was designed to certify the warfighting readiness of the Army's digital force, the 4<sup>th</sup> Infantry Division, at the brigade level. The event took place during a training rotation at the National Training Center. Data from all these events was limited to recording of digital message traffic and observations by Subject Matter Experts. The Army Test and Evaluation Command (ATEC) will use data from these events as part of their continuous evaluation of the FAAD system.

## **TEST & EVALUATION ASSESSMENT**

The FAAD C3I and GBS systems have been shown to significantly enhance the accomplishment of low altitude, short-range air defense missions when compared to previous capability. The ability of STINGER-equipped units to engage hostile aircraft at longer ranges, particularly before threat aircraft ordnance release, offers greatly improved protection of friendly ground units. However at longer ranges, positive identification of unknown aircraft is more difficult, and fratricide, first observed during the 1994 IOT&E, continues to be a serious problem for the combined ADA force (Patriot, Marine Corps SHORAD weapons/crews and FAAD C3I/Sentinel). The inability of electronic identification devices to correctly identify all friendly aircraft requires soldiers to visually identify all unknown aircraft as either friend or foe. For example, during the 2000 All Service Combat Identification Evaluation Test, there were several instances of fratricide by the combined short-range air defense units operating with FAAD C3I.

The FAAD C3I LUT in 2002 re-examines fratricide issues and also addresses several new issues that relate to the use of the FBCB2 V4 computer. The Tactics, Techniques, and Procedures for operating the FAAD C3I system on the FBCB2 computer need to be developed. There have been operational shortfalls in the air defense mission due to frequent failures and reboots of the FBCB2 Applique+ Version 3 computer. The reboot time has taken up to six minutes at ambient temperatures, and longer at

higher temperatures. The current version of the FBCB2 computer, version 4, appears to have resolved the failure/reboot issues as seen in recent events.

Another developing issue is the capability of the tactical internet to support the movement of information within an Army division in a timely manner. In past events, the size of the tactical internet appears to interfere with getting air track information from the FAAD sensors to the FAAD shooters. During the Division Capstone Exercise 1 exercise in 2001, the overall message completion rate was approximately 50 percent. During the FBCB2 Field Test 3 in FY00, where only a slice of the network was present, there was no significant degradation in message completion rates. The FY02 FAAD C3I LUT has a communications network of only 20 EPLRS radios not making it impossible to resolve this issue. The FAAD evaluation community is aware of the communications network issue and is looking at alternative sources of data such as the FBCB2 Field Test 4 and the FBCB2 IOT&E to help address this issue.

The FAAD C3I and GBS LUT in FY02 examines the effectiveness and suitability of version 5.2 software, and will address fratricide by employing both friendly and hostile aircraft. In the Army's new integrated, networked command and control environment, it is critical that the impact of network loading be tested and evaluated as early as possible and always in operational testing. The development of a realistic command, control, and communications driver is critical for providing an adequate and realistic operational environment for testing.

This Page Is Intentionally Left Blank

## **INTERIM ARMORED VEHICLE (IAV)**



The Interim Armored Vehicle (IAV) program is a family of medium armored vehicles intended to equip the Army's Interim Brigade Combat Team (IBCT). It is based on the Light Armored Vehicle (LAV) III and will consist of two basic variants, the Infantry Carrier Vehicle (ICV) and the Mobile Gun System (MGS). The ICV is, in turn, the baseline vehicle for eight additional configurations, which are based on the same platform as the ICV. These configurations are the mortar carrier, the anti-tank guided missile vehicle, the reconnaissance vehicle, the fire support vehicle, the engineer squad vehicle, the commander's vehicle, the medical evacuation vehicle, and the Nuclear Biological Chemical (NBC) reconnaissance vehicle.

The Key Performance Parameters (KPP) defined by the Army for all vehicles in the IAV family are: (1) hosting and effectively integrating existing and planned Army Command Control Communication Computer Intelligence Surveillance Reconnaissance C4ISR systems; and (2) transportable in a C-130 aircraft. The ICV and engineer squad vehicle have an additional KPP of being capable of carrying an infantry squad with its individual equipment. The MGS has an additional KPP of being capable of defeating a standard infantry bunker and creating an opening in a reinforced concrete wall with its main armament.

### **BACKGROUND INFORMATION**

The Army initiated the IAV program in FY00 to provide a family of vehicles with the capabilities necessary to support the Army's IBCT. The IBCT is intended to satisfy a requirement for a combined arms team with enhanced strategic deployability. The IBCT is envisioned to be more strategically deployable than existing Army heavy forces, while having greater tactical mobility than existing light forces. While the IBCT is intended to be employable across the full spectrum of combat, the Army envisions its most likely operating environment to be small-scale contingencies in complex and urban terrain against low end to mid-range threat forces.

In November 2000, the LAV III was selected by the Army as the IAV platform. Most of the IAV configurations are assessed by the Army to be production-ready, because the base LAV III vehicle is currently in production for other countries. Developmental work is expected only for the MGS, NBC reconnaissance vehicle, and Fire Support Vehicle (FSV). All other configurations will integrate existing equipment to provide the relevant mission packages. Installation of FBCB2 digital C2 will be accomplished by the Army at user sites after the contractor delivers the vehicles.

## **TEST & EVALUATION ACTIVITY**

IAV T&E activities to date have focused on TEMP development to include development of an Operational Test and Live Fire Test and Evaluation strategy. The Director approved the initial IAV TEMP in November 2000 incorporating the details of the selected contractor's proposal and the LAV III specific configurations. An updated TEMP is expected in the near future.

The TEMP contains provisions for a battalion-size IOT&E that will be conducted with all IAV variants and configurations not requiring significant developmental work.

The requirement for the Comparison Evaluation was waived in the National Defense Authorization Act for FY02 but requires the Secretary of Defense to certify five specific criteria are met.

IOT&E will be conducted with two live IAV companies and one IAV company in simulation, provided the simulation is validated. Additionally, battalion and brigade level combat support and combat service support elements such as reconnaissance, engineer and anti-tank units will participate. This task force will operate under the command and control of a battalion tactical operations center with complete Army Tactical Command Control System (ATCCS) digital C4ISR systems.

It is currently anticipated that all IAV variants and configurations will be available for IOT&E with the exception of the MGS, NBC reconnaissance vehicle, and the FSV. Additionally, the mortar carrier will be available with a dismounted mortar only, as a soft-recoil mortar is necessary for mounted mortar firing. The Army does not currently possess such a mortar. Additional OT events have been planned for those configurations not available for the first IAV IOT&E.

The initial IAV Live Fire Test and Evaluation strategy calls for testing three MGSs, three ICVs, and one each of the ICV-based configurations. The scope of the full-up, system-level tests call for up to 120-test events spread among up to ten test vehicles.

Live Fire Testing begins 2QFY02 and the IAV IOT&E is currently scheduled to begin in 2-3QFY03.

## **TEST & EVALUATION ASSESSMENT**

The IAV T&E program will be inherently challenging due to the need to test and evaluate ten different variants and configurations, each of which performs a different combat function. The Army has proposed a robust test program that includes all but three of the variants in the first IAV IOT. This will allow evaluation of system and unit effectiveness and suitability. The scope of testing for other variants depends on the extent to which common issues can be resolved in the first IOT. Additionally, each platform's performance will be, in large measure, dependent upon the successful integration of a variety of mission packages. Of particular interest will be the integration and performance of FBCB2 digital command and control. The organizational and operational concepts for the IAV-equipped IBCT are, to a significant degree, based upon the information superiority presumed to be provided by FBCB2 as well as the other ATCCS systems. Additionally the successful integration of Government Furnished Equipment mission packages such as the M707 Striker into the Fire Support Vehicle and the Long Range Acquisition System into the Reconnaissance Vehicle will be essential to the IAV program.

The development of the MGS will likely be the greatest program challenge. The integration of the 105 mm main gun on the LAV III chassis is, to date, largely unproven. Since the MGS will not be



ready for fielding with the first brigades, the Army is pursuing a modification to the Tube launched Optically tracked Wire guided missile to give it enhanced capability against bunkers.

The Army's assumption that the majority of the selected IAV configurations and variants are production ready is based upon the LAV III chassis only and does not consider the total system integration of mission packages for each configuration, to include FBCB2. Much of the planned T&E effort will necessarily focus on system integration issues.

This Page Is Intentionally Left Blank

## JAVELIN ANTITANK MISSILE



The Javelin is a man-portable, fire-and-forget, medium anti-tank missile, employed by dismounted troops, to defeat current and future threat armored combat vehicles out to 2,500 meters. Javelin attacks most targets from the top to defeat explosive reactive armor; it also has the capability, in the direct fire mode, to attack targets under cover. The program provides a medium anti-tank capability for dismounted (including light) forces, while the Tube-launched Optically-controlled Wireless-guided Fire and Forget and Line-of-Sight systems will provide heavy anti-tank capabilities for all light forces.

The tactical Javelin consists of a missile in a disposable launch tube and a re-usable Command Launch Unit (CLU) with a trigger mechanism and day/night-sighting device for surveillance and tracking, and built-in test capabilities. Training equipment includes classroom-level devices and a Field Tactical Trainer that supports both fixed-location range training, and participation in realistic force-on-force exercises.

### **BACKGROUND INFORMATION**

The IOT&E, completed in December 1993, concluded that Javelin was operationally effective, but required further assessment for operational suitability. DOT&E's B-LRIP and LFT&E lethality reports concluded that the Javelin Enhanced Producibility Program system design was operationally effective, operationally suitable, and lethal. The Milestone III Full-Rate Production (FRP) decision was made in May 1997.

To enhance producibility and to reduce cost, post-FRP design changes were incorporated into the missile as well as the CLU. Unanticipated missile reliability problems from these changes were uncovered and delayed the missile's transition from LRIP to FRP, postponing System Maturity by one year beyond the initially scheduled date of May 2000.

Testing and analysis of developmental test data, including 38 missile firings in April-December 2000 verifying the final design, demonstrated that all System Maturity requirements had been attained. Several changes to the warhead design had been proposed. The Javelin Enhanced Tandem Integration (JETI) modification is scheduled to be cut into production in the third FRP year. No additional dedicated LFT&E was conducted for JETI, since only the manner in which the existing precursor and main charge warheads are mounted within the missile has changed (i.e., the warheads themselves are unchanged).

## **TEST AND EVALUATION ACTIVITY**

Javelin testing in FY01 consisted of the PM's continuing technical and lot acceptance testing of missiles and other system components. Flight testing against Active Protection Systems (enhancements to threat armor vehicles designed to detect and destroy incoming missiles) is underway. The final phase of JETI testing, which included three firings of tactical missiles by military gunners against operational tank targets, was conducted in FY01 as part of the third production year qualification test program. The final shot was fired against a threat tank that contained a tactical load of live propellant charges. After the missile impacted the turret, the warhead's shaped charge perforated the armor and detonated the onboard propellant, resulting in total destruction of the tank target.

## **TEST AND EVALUATION ASSESSMENT**

The initial design of the Javelin system was adequately tested in accordance with the OSD-approved TEMP and determined to be operationally effective, operationally suitable, and lethal. The currently designed Javelin missile, CLU, and training devices meet or exceed their System Maturity requirements. Recent testing, including missile flights against threat Active Protection Systems assessing JETI performance and missile qualification testing, have been highly successful.

## **LESSONS LEARNED**

No further dedicated testing is required to demonstrate System Maturity. Nonetheless, continued observation and analysis of Javelin missile and warhead performance reliability is warranted, especially as additional producibility changes continue to be implemented.

The final phase of the JETI test program demonstrated that missiles fired by military gunners could yield valid test results that support an assessment of missile lethality.

# JOINT COMPUTER-AIDED ACQUISITION AND LOGISTICS SUPPORT (JCALS) SYSTEM



The Joint Computer-aided Acquisition and Logistics Support (JCALS) system is a multi-Service, geographically distributed client-server system designed to process all data and information required to manage, control, and produce each Service's technical manuals at designated technical manual processing sites. The program is developing an infrastructure to logistically support weapons systems throughout their life cycles. At its heart is the Global Data Management System (GDMS), the middleware connecting JCALS users with legacy data repositories. The GDMS provides transparent access to data anywhere in the system regardless of where it is stored, how it is formatted, or how it is accessed. A System Operational Support Center (SOSC) provides overall system management and administration, and assists the system's several hundred functional users.

## **BACKGROUND INFORMATION**

JCALs is being developed in increments called Software Packages (SWPs). The first increment, SWP 1/2, has been fielded. The second increment, SWP 3.1, is completing DT&E. A third increment, SWP 3.3, is still in development. These SWPs contain the following general capabilities:

- SWP 1/2. A basic automated capability for accessing and exchanging technical information on weapons systems among the Services and DoD agencies. Air Force sites were provided with a modification that introduced a basic Joint Technical Manual (JTM) capability.
- SWP 3.1. Replaces Army and Navy technical manual legacy systems with enhanced JTM functionality, adds a publishing capability for the Marine Corps, affords wider connectivity (more interfaces), and provides a web-based capability.
- SWP 3.3. Provides the core functionality necessary for all the Services to routinely perform their JTM business practices without workarounds.

In 1998, ATEC, the independent OTA, conducted an IOT&E of JCALS hardware and SWP 1/2, in compliance with the TEMP approved by DOT&E in May 1997. The focus of the test was to examine technical manual activities and SOSC capabilities. DOT&E's evaluation revealed a variety of problems, and the PMO began to take corrective actions. Based on the follow-on assessments by ATEC, DOT&E concluded that JCALS was operationally effective and suitable for the Army, Navy, and Marine Corps, and it was deployed to those Services. The PMO then developed a "modified SWP 1/2" for the Air Force

that underwent rigorous regression testing in the laboratory and follow-on evaluation in the operational environments through 1999. DOT&E subsequently found the “modified SWP 1/2” operationally effective and suitable for the Air Force and it was deployed to Air Force sites.

### **TEST & EVALUATION ACTIVITY**

The TEMP was updated in April 2001. Overall requirements are based on a user-approved Joint Minimum Essential Requirements List, rather than an Operational Requirements Document. As T&E has progressed, the JCALS PM has continued to refine the JCALS acquisition strategy and the definitions of the SWPs. DT&E of SWP 3.1 was completed in late December 2001. In the final phase of software qualification testing, the software was installed and tested with operational users at 13 beta sites in CONUS that encompass all of the Services. OT&E at these sites was scheduled to begin in January 2002. OT&E for SWP 3.3 is currently planned for 4QFY02.

### **TEST & EVALUATION ASSESSMENT**

JCALs has provided better technical manual utility as the Service end users and system administrators gained experience with it. The Joint Technical Manual application is said to have done particularly well at Warner-Robins AFB, GA, where a strong effort was made to adapt business practices to the new system. However, software development complexity, integration issues, aggressive timelines, and issues identified during DT&E have continued to impact the acquisition. The 2QFY02 OT&E results and subsequent DOT&E assessment should indicate whether an enhanced JCALS has successfully overcome enough of these problems to warrant further fielding at this time.

## **JOINT LAND ATTACK CRUISE MISSILE DEFENSE (LACMD) ELEVATED NETTED SENSOR SYSTEM (JLENS)**

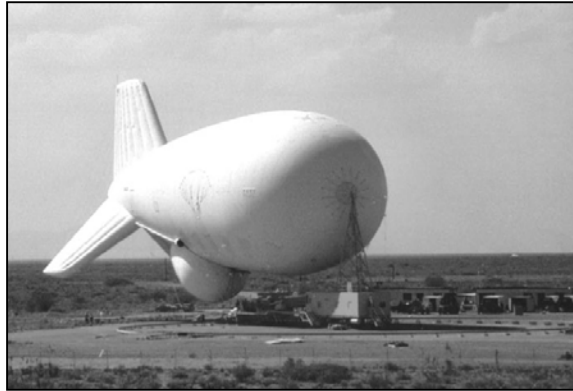

The Joint Land Attack Cruise Missile Defense Elevated Netted Sensor System (JLENS) will enhance surveillance capability and provide air defenders with improved ability to observe, assess, and support engagements over the entire air battlespace, enabling precision engagement through information superiority to the dominant maneuver force as they engage the enemy. The full-dimensional protection pillar of Joint Vision 2020 addresses the need to protect U.S. forces from this very technology that the U.S. is attempting to exploit. JLENS provides a critical link against the number-one priority of the full-dimensional protection pillar: countering air and missile threats.

### **BACKGROUND INFORMATION**

The JLENS is an airborne radar platform designed to provide surveillance and targeting quality radar data on Land Attack Cruise Missiles and other airbreathing targets. The system also acquires and tracks surface moving targets and supports detection and trajectory prediction of tactical ballistic missiles. A JLENS system consists of two aerostats, one containing a Surveillance Radar (SuR) and one containing a Precision Target Illumination Radar (PTIR). The aerostats are non-developmental 71-meter, unmanned, tethered, non-rigid aerodynamic structures filled with helium and air. Each aerostat is tethered to a mobile mooring station and attached to a processing station through a fiber optic powered tether. The SuR provides the initial target detection, cueing the PTIR, which generates an engagement quality track. The JLENS system is integrated into the Joint Tactical Architecture via Link 16, CEC, SINGARS, and EPLRS. The system provides key contributions to generation of a Single Integrated Air Picture, through the fusion of high accuracy long-range tracking and target classification information with that of other sensors in the JTAMD architecture. Both radar systems will include Identification Friend or Foe interrogators.

Shooters, such as Patriot, Navy Standard Missile, the Marine Corps Complementary Low Altitude Weapons System and the Army HUMRAAM – can use the JLENS PTIR data to engage low-flying terrain masked cruise missiles before their own ground-based sensors can detect them. JLENS supports air-directed surface-to-air-missile and air-directed air-to-air missile engagements through both the engage on remote and forward pass mechanisms.

The JLENS program is executed in two blocks. Block 1 develops the PTIR fire control radar, which has a sector search capability. Block 2 develops the full azimuth 360 degree SuR and

demonstrates its ability to hand off targets to the PTIR for engagement execution. A complete JLENS system consists of one Block 1 PTIR and one Block 2 SuR. The purchase of 18 JLENS systems consists of the purchase of 18 PTIR, 18 SuR, 36 Mobile Mooring Systems, and 36 processing systems.

### **TEST & EVALUATION ACTIVITY**

The Army has drafted a JLENS TEMP; however, the TEMP cannot be finalized or submitted until the Army completes the JLENS ORD. The operational testing of JLENS will be structured to ensure that it can support Army, Navy, and Air Force air defense systems, including Medium Extended Air Defense System, Patriot, fighter- and ground-launched AMRAAM, and Standard Missile.

The JLENS program office supported a demonstration of the viability and utility of an elevated sensor and the engage on remote (EOR) mechanism. This demonstration leveraged a Patriot/AEGIS EOR Advanced Concept Technology Demonstration. The demonstration consisted of an Aegis cruiser in the Gulf of Mexico and a Patriot located at Eglin AFB. In the demonstrations, JLENS simulated detections of a simulated cruise missile that was below the radar horizon for the weapons platforms. A prototype JLENS processing station passed the simulated detections via CEC to both the AEGIS cruiser and the Patriot, which then simulated engaging the target cruise missile.

### **TEST & EVALUATION ASSESSMENT**

None.



## JOINT SIMULATION SYSTEM (JSIMS)

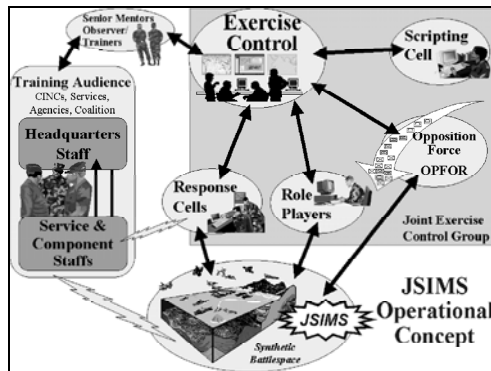

The Joint Simulation System (JSIMS) is a single, distributed, and seamlessly integrated simulation environment that permits integration of real-world and simulated assets of the U.S. Military Services and their allies on a virtual battlefield. The JSIMS virtual battlefield is simulated by a High Level Architecture compliant federation of component models. The component models include the National Air and Space Model (NASM), Warfighters' Simulation (WARSIM), WARSIM Intelligence Model (WIM), JSIMS Maritime, the Defense Intelligence Agency's Object-oriented Model of Intelligence Operations (DOMINO), Joint Signals Intelligence Simulation (JSIGSIM), and National Simulation (NATSIM). JSIMS is to provide a real-time simulation capability that can be configured for use in exercises of differing duration, scenarios, and complexities. It is to interface with real-world C4I systems, providing a training environment that should be transparent to the training audience. JSIMS is to include scenarios that reflect the transition of military forces into less conventional roles such as multinational peacekeeping and humanitarian assistance. At Initial Operational Capability (IOC), JSIMS will be an accredited simulation environment to support joint training for unified combatant command staffs, joint task force (JTF) commanders and staffs, and JTF component commanders and staffs. At Full Operational Capability, JSIMS is to evolve to support professional military and senior officer education, mission planning, mission rehearsal, and doctrine development.

### BACKGROUND INFORMATION

In December 1999, the Under Secretary of Defense for Acquisition, Technology and Logistics (USD (AT&L)) re-designated JSIMS as an Acquisition Category ID program with USD (AT&L) as the Milestone Decision Authority. The JSIMS Program Manager was moved to the Army from the Air Force and reports directly to the Army Acquisition Executive. The JSIMS Program Manager is responsible for overall materiel development. The United States Joint Forces Command Joint Warfighting Center (JWFC) is the user representative. The Air Force Operational Test and Evaluation Center (AFOTEC) resigned in October 2001 as the lead Operational Test Agency (OTA). The Navy's Commander, Operational Test & Evaluation Force (COMOPTEVFOR) agreed to be the lead OTA in 2QFY02. Nine Service and Defense Agencies make up the Development Agents and are responsible for the development of component models and workstation software. The JSIMS Alliance Executive Office (AEO) directs the integration of the individual Development Agents' products.

Development activity is proceeding through a series of five integration events, which will conclude in a full system test in FY02. The Multi-Service Operational Test and Evaluation (MOT&E), a

geographically distributed training exercise using Unified Endeavor 03-1, will support a full-rate production decision in FY03.

### **TEST & EVALUATION ACTIVITY**

During FY01, the AEO completed the first two of five integration events leading up to the completion of JSIMS Version Release 1.0. These events are designed along a crawl, walk, run approach, starting with ensuring the most basic functions of federating simulations can be accomplished. Later integration events beginning in FY02 will look at cross-federate functions (for example flying planes in NASM and hitting ground targets in WARSIM).

DOT&E approved the AFOTEC JSIMS Operational Test Concept in April 2001. The operational test strategy includes an Early Operational Assessment (EOA) of JSIMS during the JWFC System Functional Assessment (2QFY02) and a combined DT/OT in conjunction with the JWFC System Validation Event in CY02 to determine readiness for the MOT&E later in FY03. The Test and Evaluation Integrated Product Team developed the Test and Evaluation Master Plan (TEMP) and was poised to send the TEMP to OSD for approval in 1QFY02. Due to the resignation of AFOTEC as the lead OTA, the TEMP was pulled back from further coordination.

### **TEST & EVALUATION ASSESSMENT**

The initial AFOTEC Operational Test Concept was based largely on a questionnaire-based, qualitative assessment. DOT&E recommended the addition of objective measures of effectiveness and placing additional emphasis on areas such as C4I system-to-simulation interoperability, information assurance, task accomplishment, and logistics supportability. The integration of multiple training simulations and tools developed by multiple Services and Agencies provides a unique test and evaluation challenge. It is imperative that all Service OTAs are part of the planning team and tasked to provide input on how to assess and evaluate their part of the training.

The resignation of AFOTEC as the lead OTA in October 2001 has created a significant delay in approval of the TEMP as well as planning for the MOT&E and the events leading up to the MOT&E. The Early Operational Assessment did not occur due to lack of a lead OTA. Any revisions to the approved strategy by COMOPTEVFOR will require approval by DOT&E and the TEMP re-coordinated among the services, which may impact existing program schedules.

Combining multiple independent development efforts into incremental integration and test events has proven to be a viable means for evaluating exit and entrance criteria and minimizing associated costs. The integration events have required more time than originally planned by the AEO. Progress is being made, but delays have consumed available time in the schedule. Because these integration events are necessary to achieving a successful MOT&E and full-rate production decision, any further movement of these events in the schedule may impact the milestone date or cause a reduction in functionality delivered at IOC. This integration, validation, and testing is a challenge, but will result in a viable joint training tool for operational test and evaluation.

## JOINT TACTICAL RADIO SYSTEM (JTRS)

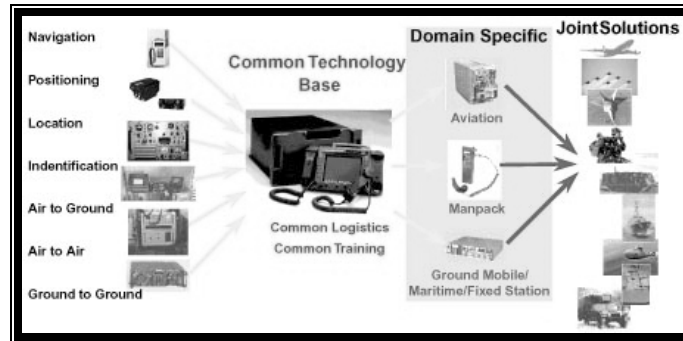

The Joint Tactical Radio System (JTRS) is a family of high-capacity, programmable, multi-band/multi-mode tactical radios to provide both line-of-sight and beyond-line-of-sight communication capabilities to the warfighter. The JTRS uses software defined radio technology to achieve flexibility and interoperability and provide the ability to easily upgrade. The Capstone JTRS program maintains the Software Communications Architecture (SCA) and waveform software using prototype laboratory radios of the Modular Software Radio Consortium. The JTRS radios themselves will be developed and acquired in Service-led acquisition efforts called clusters. The first cluster is an Army-led effort for ground vehicular, Army rotary wing, and Air Force Tactical Air Control Party vehicular radios. Remaining clusters are yet to be fully defined.

### **BACKGROUND INFORMATION**

The Quadrennial Defense Review in 1997 identified the need and benefits of combining various Service radio acquisition programs incorporating programmable software technology. The USD (AT&L) in April 1998 requested that each Service Acquisition Executive aggressively pursue the necessary steps to achieve the goal of minimizing new programs and migrating existing development programs for software-based radio communication systems to a single acquisition program. The JTRS Joint Program Office (JPO) was established to coordinate the program. The importance of the JTRS effort was emphasized in an August 1998 ASD (C3I) memorandum directing that all Service efforts to independently develop and acquire any radio system be held in abeyance. The Joint Requirements Council approved an updated JTRS Operational Requirements Document on March 1, 2001.

The JTRS JPO defined an open SCA for the Services to acquire software-based radios. The SCA is to ensure acquisition efficiency across the Department, foster the use of commercial-off-the-shelf products, and promote interoperability. The JTRS JPO, in conjunction with Service radio acquisition program offices, will acquire waveform software that can be ported to the SCA-compliant JTRS radios during their development. Depending on individual Service requirements, the Service program office will procure SCA-compliant radios in clusters. An acquisition cluster is a group of radios meeting similar requirements in a given timeframe.

Software waveforms developed for Cluster 1 include Single Channel Ground/Airborne Radio System (SINCGARS), Enhanced SINCGARS Improved Product (ESIP), HAVE QUICK II, Ultra High Frequency Demand Assigned Multiple Access (UHF DAMA), High Frequency Single Sideband with Application Link Enabling (HF SSB with ALE), Enhanced Position Location Reporting System

(EPLRS), Link-16, Very High Frequency AM (VHF AM), and Wideband Networking Waveform (WNW). All but the WNW replace legacy waveforms.

### **TEST & EVALUATION ACTIVITY**

The primary test and evaluation activity during FY01 was the definition of test strategies for both the Capstone JTRS and the Army-led JTRS Cluster 1 efforts via the Integrated Product Team (IPT) process. Development of Test and Evaluation Master Plans (TEMPs) and Critical Operational Issues and Criteria were substantial efforts. The TEMP's support a Milestone B acquisition review in FY02.

### **TEST & EVALUATION ASSESSMENT**

A test strategy to support the Army's Cluster 1 acquisition strategy evolved over the past year. The JTRS Cluster 1 is proposing an ambitious acquisition schedule. The proximity of the Milestone C Low Rate Initial Production decision and the IOT&E is of concern. At this early stage in the development, the risk is moderate to high regarding the ability of the Cluster 1 contractors to develop the waveforms and produce sufficient quantities of JTRS Cluster 1 radios to support the complete IOT&E process, including training and development of tactics, techniques, and procedures.

Early involvement through the IPT process has defined Critical Operational Issues and Criteria that are operationally meaningful and measurable for assessing the JTRS contribution to operations. This early cooperation improves the quality of both the system development and test program and provides meaningful assessments for future decisions.

## **LINE-OF-SIGHT ANTI-TANK MISSILE (LOSAT)**



The Line-Of-Sight Anti-Tank Missile (LOSAT) is an anti-tank weapon system designed to provide lethal fire to defeat any known or projected armor systems at ranges greater than 4,000 meters. It uses kinetic energy as its kill mechanism and is the first of the Army's Kinetic Energy Missile programs. LOSAT, which will be mounted on a U.S. Army High Mobility Multi-Purpose Wheeled Vehicle (HMMWV) chassis, is being developed as a supplemental anti-armor capability for fielding in five light divisions currently equipped with Tube-launch Optically-controlled Wire-guided (TOW) and Javelin anti-tank systems. The basic organizational unit for LOSAT will be a five-man squad equipped with two HMMWVs and a high-mobility Missile Resupply Trailer. One HMMWV, called the Fire Unit (FU), will be the LOSAT missile launch vehicle that can carry four ready-to-fire missiles. The fire control system in the FU is based on the Improved Bradley Acquisition System, which features an acquisition system using a second-generation Forward-Looking Infrared sensor and a daylight TV. The other vehicle, the Resupply HMMWV, will tow the missile resupply trailer, which will carry eight additional missiles. The system is to be deployable by strategic (e.g., C-5, C-17) and tactical airlift (C-130), and external air transport via UH-60 and CH-47 helicopters.

### **BACKGROUND INFORMATION**

The LOSAT program was designated as an Advanced Technology Demonstration (ATD) in 1992 and upgraded to an Advanced Concept Technology Demonstration (ACTD) in 1997. The program was restructured in 1999 to enter an Engineering and Manufacturing Development-like phase, referred to by the Program Manager as ACTD Plus, to prepare for an LRIP decision in early FY04. This LRIP decision in FY04 will be followed by IOT&E in FY05. Results of this testing will support a full-rate production decision in early FY06. In 2000, the restructured LOSAT program was designated an ACAT II program. OSD has designated LOSAT for DT&E, OT&E, and LFT&E oversight. Furthermore, LOSAT's LFT&E program will require assessments for both the vulnerability of the system (Fire Unit, Resupply Vehicle, and Resupply Trailer) and the lethality of the missile.

### **TEST & EVALUATION ACTIVITY**

During the year, the principal test activities were two Risk Reduction Flights successfully launched from White Sands Missile Range, NM, in May and July 2001. In each test, a contractor gunner remotely launched the missile from a stationary LOSAT FU. The tested hardware included recent design

innovations, including new HMMWV FU configurations and several modifications to the missile. As planned, the missile's Aft Looking Receiver and FU's laser link were not functional and, as such, there was no capability for the FU to provide position updates to the missile during the flight.

Additionally, test activities during the year included the planning of the test program, and a revised TEMP. The current draft TEMP encompasses: (1) Dismounted Battlespace Battle Lab Demonstrations to be conducted in the FY04 timeframe to examine deployability and survivability; (2) the Limited Users' Test to be conducted in FY04 should provide information to support the LRIP decision; (3) the IOT&E, comprised of live firings and force-on-force exercises, to be conducted in FY05; and (4) a combined vulnerability and lethality LFT&E strategy.

### **TEST & EVALUATION ASSESSMENT**

All prior testing, including the two Risk Reduction flights in FY01, has been of a technical nature. Results to date indicate that the LOSAT is capable of defeating any current or projected tank it hits. Furthermore, launch effects from shock, g-load, flash, toxic gases, pressure, and sound (in and outside the vehicle) have been demonstrated to fall within the Army's acceptable ranges for human factors.

The kinetic energy missile is lethal given that it hits its intended targets. Missile firings against high-fidelity targets will confirm this against moving targets, and other configurations more difficult to hit. The survivability of the system itself is more problematic. The Army has chosen to trade-off ballistic protection of the LOSAT vehicles and trailer for enhanced deployability as part of a light early entry force. As such, to ensure that the LOSAT system remains sling-loadable from a UH-60 helicopter, the system's armor protection levels were constrained. The LFT&E program will assess the degree to which the LOSAT system, including the missile, both HMMWV vehicles, and the loaded trailer, is vulnerable to the expected threats. Extensive efforts have been taken during FY01 to develop a Live Fire Strategy for inclusion in the revised TEMP. This strategy describes critical vulnerability and lethality issues, and the scope of testing needed to address them, including the need for more than one FU for full up, system-level LFT&E to support the planned full-rate production decision in early FY06.

## M829E3 120-MM APFSDS-T CARTRIDGE



The M829E3 Armor-Piercing Fin-Stabilized Discarding Sabot-Tracer (APFSDS-T) cartridge is one of the 120mm main gun rounds designed for the Abrams tank. It is a Kinetic Energy (KE) round that fires a depleted uranium rod designed to penetrate and destroy enemy heavy armored vehicles. The focus of M829E3 development is on propulsion improvements. The design is driven by the need to counter KE-effective Explosive Reactive Armor (ERA) and the desire to destroy targets at longer range than is possible with the current M829A2.

The improved tank round will support the dominant maneuver force aspect of Joint Vision 2020 by enhancing the lethality of the Abrams main battle tank.

Due to the funding threshold, the M829E3 program does not require operational test oversight from this office. However, the Army nominated this program for LFT&E oversight based on projected program cost.

### **BACKGROUND INFORMATION**

LFT&E for this program includes both lethality and vulnerability evaluation. System lethality will be assessed with respect to expected threat tanks. The vulnerability of the Abrams tank will be assessed to ensure there is no increase in system vulnerability when carrying the M829E3 as compared to the current ammunition (M829A2). The LFT&E strategy was approved in 1QFY00 and includes both lethality and vulnerability test requirements. Event design plans for lethality and vulnerability testing were approved in 3QFY01.

The lethality evaluation for the M829E3 will leverage data from previous Joint Live Fire testing of large caliber KE munitions against threat tanks, EMD testing of production representative hardware against range targets, and a two-phase Production Qualification Test (PQT) series. Phase I PQT involves firing of M829E3 ammunition (approximately 60 rounds) against range targets, with and without ERA, representative of threat tanks. Phase II involves firing (approximately 30 rounds) against shotline simulant targets, specifically designed and constructed to represent specific combat-representative shotlines through threat tanks. Phase I PQT is scheduled to begin in August 2001.

The vulnerability evaluation will leverage data from previous and ongoing developmental test activities, including propellant characterization testing and simulated compartment tests, and a minimum

of three full-scale compartment (BH&T) tests. The full-scale compartment tests will use M829E3 stowage in two different turret load plan configurations and a single hull stowage load plan. Depending on the outcome of these full-scale tests, as many as two further full-scale tests may be conducted with threats used in previous Abrams ammunition stowage vulnerability testing.

### **TEST & EVALUATION ACTIVITY**

EMD test activity during FY01 included firing a significant number of production representative rounds against range targets representative of the expected target set. The results of these tests are classified.

### **TEST & EVALUATION ASSESSMENT**

The data from EMD testing of production representative hardware will be used, where appropriate, to supplement testing conducted in PQT. The LFT&E IPT reviewed these data and developed the Phase I PQT test matrix in order to best explore the performance envelope of the M829E3 against the full range of engagement conditions and expected targets.

Shotline simulant testing in Phase II PQT will serve to demonstrate the performance against targets representative of threat vehicles, and will directly support validation of M&S tools that will be used to estimate performance against the expected threat.

### **LESSONS LEARNED**

The provision for use of shotline simulant targets in Phase II PQT represents an intelligent approach to realistic lethality testing given the difficulties inherent in acquiring representative threat targets and testing with ERA and depleted uranium ammunition.



## MANEUVER CONTROL SYSTEM (MCS)



The Maneuver Control System (MCS) is the central command and control system for Army maneuver elements in battalion through corps echelons. MCS consists of a network of computer workstations that integrate information from subordinate maneuver units with those from other Army Battle Command System battlefield functional areas to create a joint common data base referred to as the Common Tactical Picture. Tactical information products, such as situation maps and reports, allow the display and manipulation of this information. MCS also provides a means to create, coordinate, and disseminate operational plans and orders. MCS's role in communicating battle plans, orders, and enemy and friendly situation reports makes it a key component of the Army's ongoing effort to digitize the battlefield. MCS capabilities are being developed in blocks. The MCS Block III initiated, and the current Block IV increases, the integration between the various Army Battle Command Systems (ABCS): All Source Analysis System, Forward Area Air Defense System, Advanced Field Artillery Tactical Data System, Combat Service Support Command System, and Force XXI Battle Command Brigade and Below (FBCB2).

### **BACKGROUND INFORMATION**

In 1980, the Army fielded the first MCS system with limited command, control, and communications capabilities to VII Corps in Europe. In 1987, the Army performed post-deployment tests on MCS software Version 9 which led the Army Materiel System Analysis Activity to conclude that MCS did not exhibit adequate readiness for field use and that further fielding should not occur until the problems were resolved. The Army fielded Version 10 in October 1988. These early versions of MCS are no longer in the force structure.

In 1996, the Army postponed the Block III IOT&E and initiated development of MCS Block IV. This effort involves substantially different software, including the required Defense Information Infrastructure Common Operating Environment. An operational assessment in 1997 supported limited procurement of Block III for the training base. The Army conducted the MCS Block III IOT&E in June 1998. DOT&E concluded that MCS Block III was neither operationally effective nor operationally suitable. The Army subsequently restructured the MCS program, did not field the Block III, and designated the Block IV as the version planned for testing in an IOT&E to support the full-rate production decision.

The Army has restructured the battlefield digitization architecture since the Block III IOT&E. FBCB2 is no longer a separate system in the Tactical Operations Centers (TOC), but resides as a software module on the MCS and TOC server to support processing of incoming situational awareness information. MCS also provides the common software modules, such as the Joint Common Data Base and Common Message Parser that support creation of the Common Tactical Picture by allowing the ABCS systems to share data and messages.

### **TEST & EVALUATION ACTIVITY**

The MCS Block IV IOT&E planned to collect data in a series of five events starting in December 2000 and concluding with a combined IOT&E with the FBCB2 in December 2001. Software development and performance difficulties forced postponement of formal MCS IOT&E evaluation. An Independent Developmental Test completed in June 2001 and subsequent Production Prove-out Test in July 2001 confirmed that the development was not proceeding as planned. As a result, the Army cancelled evaluation of the MCS in the Division Capstone Exercise 2 and postponed the MCS IOT&E for a year. Postponement of the IOT&E led to a review of the MCS operational requirements and revision of the test strategy.

### **TEST & EVALUATION ASSESSMENT**

The MCS Block IV effort is complex and requires developing, integrating, and configuration management of diverse software components including commercial and government furnished foundation products and software from the other ABCS programs. The developmental testing and operational assessments completed in 2001 demonstrated the development and integration of software was not providing the required capabilities to meet the scheduled IOT&E in December. The Army correctly postponed the MCS IOT&E until software was more mature and integration had proven successful. The new test and evaluation strategy projects an MCS Block IV IOT&E no earlier than November 2002. The Army is taking this time to review the operational requirements, revise the acquisition strategy, and define a test strategy through the Integrated Product Team process.

Future testing of MCS requires the ABCS system-of-systems environment, including FBCB2 and division-level TOC dispersion and displacements, to demonstrate the ability of MCS to maintain the common tactical picture for the maneuver force on a dynamic battlefield. The importance of movement for TOCs cannot be overstated, particularly with the growing emphasis that the threat is placing on disruption and destruction of our command and control capabilities, and the reliance on mobility to enhance survivability in the Army's transformation to lighter forces.

The ability to evaluate ABCS components as individual programs is becoming more difficult as the Army continues to integrate the software and foundation products that comprise these systems, as well as the information into the Common Tactical Picture. An assessment of operational effectiveness and suitability is no longer limited to what the system provides within a single functional area, but now expands to what the integration of that information with other functional areas contributes to the commander's ability to prosecute the mission using MCS. Testing must include all the ABCS components to assess operational effectiveness and suitability. The Department should consider Capstone acquisition, development, testing, and fielding strategies to more effectively and efficiently support, fund, and synchronize the ABCS programs.

## **MULTIPLE LAUNCH ROCKET SYSTEM (MLRS) M270A1 LAUNCHER**



The Multiple Launch Rocket System (MLRS) provides an all-weather, indirect, area fire weapon system to strike high-payoff threat targets at all depths of the tactical battlefield. MLRS consists of a self-loading launcher with an onboard fire control system. The MLRS launcher is the standard U.S. Army platform for firing surface-to-surface artillery rockets and missiles. It is mounted on a mobile, tracked vehicle that carries 12 rockets in two, six-rocket Launch Pod Containers or two Army Tactical Missile System (Army TACMS) missiles, which can be fired individually or sequentially. Rockets have a range beyond 30 kilometers, and the Army TACMS Block IA missile can reach beyond 300 kilometers.

The M270A1 program includes two major upgrades to the current M270 launcher. First is the Improved Fire Control System (IFCS), which replaces obsolete, maintenance-intensive hardware and software. It provides growth potential for future munitions and the potential for reduced launcher operation and support costs. IFCS includes a Global Positioning System (GPS)-aided navigation system. Second, the Improved Launcher Mechanical System (ILMS) improves reaction times and decreases the time to aim, fire, move and reload the launcher. A faster launcher drive system that moves simultaneously in azimuth and elevation reduces the traverse time from the stowed position to worst case aimpoint by approximately 80 percent, and decreases the mechanical system contribution to reload time by about 40 percent. Additionally, the M270A1 program includes the re-manufacture of selected components and the application of selected Engineering Change Proposals to the basic M270 launcher to bring all launchers to the same configuration.

### **BACKGROUND INFORMATION**

MLRS initial operational capability occurred in 1983. To combat growing obsolescence, the Army initiated the IFCS program in 4QFY92. In 4QFY95, the Army began the ILMS program to address a requirement for faster prosecution of highly mobile, short-dwell targets. In FY96, the Army combined the IFCS and ILMS test programs under the M270A1 to undergo system-level testing. In May 1998 LRIP of IFCS and ILMS hardware modification kits was approved. In 4QFY98, the 486-based executive processor was replaced with a PowerPC processor, and the proprietary software operating system was replaced with the commercial VxWorks software operating system.

In July 1999, IOT&E slipped 22 months to allow the program time to fix problems identified in developmental testing and the Maintainability Demonstration, and to include the planned replacement of the executive processors and operating system. In March 2000, DOT&E approved a revised M270A1 TEMP. Milestone III is scheduled for March 15, 2002.

In 1997 and 1998, the Army conducted an MLRS survivability program (SP) to complete survivability estimates, determine the effects of improvements on survivability of the fielded launcher, develop tactics to enhance MLRS launcher and crew survivability, and develop changes needed for the M270A1. The SP assessed survivability against ballistic threats and identified material and tactics changes needed to decrease vulnerabilities. Blast and shock tests were completed in 1997, payload sensitivity and component experiments in 1998 and a vulnerability analysis in 1999.

### **TEST & EVALUATION ACTIVITY**

In January through April 2001, crewmen and maintenance personnel performed a series of tasks in the M270A1 Maintainability and Logistics Demonstrations. Flight-tests in 2QFY01 of an ATACMS Block I missile, practice rockets, and M26 basic rockets; the Extended System Integration Test (ESIT) of an M270A1 platoon in April; and the Logistics and Maintainability Demonstrations in February through April showed that the launcher was ready for IOT&E.

The IOT&E was conducted from August to October 2001 in accordance with a DOT&E approved TEMP and test plan. DOT&E observed both the ground and flight phases. The IOT&E ground phase consisted of three 96-hour field exercises for one M270A1 launcher platoon, side-by-side with an M270 platoon and included the live firing of reduced-range practice rockets. The flight phase consisted of 35 M26 rockets, 6 extended-range rockets, and one ATACMS Block IA missile.

In October 2001, the materiel developer conducted a three-day exercise of time-ordered events to verify that minor changes made following the IOT&E software release did not create unexpected consequences. Additional flight tests will be conducted at White Sands Missile Range, NM, to ensure that software changes do not affect the launcher's ability to fire live munitions.

### **TEST & EVALUATION ASSESSMENT**

IFCS software and safety problems continued in early 2001. The safety problems involved an uncommanded LLM movement and undamped oscillations around the commanded azimuth. Software, hardware, and procedural changes were made to mitigate these problems.

During the Logistics Demonstration, soldiers successfully conducted 198 of 201 selected tasks. During the Maintainability Demonstration, maintenance personnel detected and isolated more than the required 95 percent of 115 electrical and mechanical faults tested.

A number of system vulnerabilities were found in the survivability program. Some can be corrected with minor engineering changes to such components as the fuel filter bracket and radiator cover to reduce the vulnerability of the system to cheap automotive kills. Others, however, are more significant, and their correction will entail additional armor protection to lessen the likelihood of payload initiation. The PMO funded the Army Research Laboratory (ARL) to investigate ways to improve the armor protection of the MLRS Launcher Loader Module, to inhibit a payload reaction from enemy fire. ARL is conducting a model-based analysis of three viable engineering solutions to improve payload protection. The analyses are not yet complete.

Analysis of the IOT&E data is ongoing. The emerging results show that the M270A1 launchers performed more effectively and reliably than the M270 launchers during the IOT&E. DOT&E will submit a B-LRIP Report to Congress prior to the Army's full-rate production decision.

# PROPHET



Prophet is a suite of division-level Signals Intelligence/Electronic Warfare (SIGINT/EW) sensor and jamming subsystems. It consists of two acquisition programs: (1) Prophet, formerly known as Prophet Ground; and (2) Division Tactical Unmanned Aerial Vehicle (TUAV)-Signals Intelligence Program (DTSP), formerly known as Prophet Air.

The Prophet ground system's primary mission will be to provide force protection information to maneuver brigades and armored cavalry units in near-real time. The force protection is based on Prophet's ability to provide timely reports on opposing force voice activity. Prophet Block I will consist of an Electronic Warfare Support system mounted on a Heavy HMMWV. The receiver/processor can be removed from the vehicle to operate as a dismounted man-pack system in support of forced entry airborne or air assault operations. The mounted system can operate both from a stationary position and on-the-move. Prophet Control, a team of military intelligence analysts equipped with an All Source Analysis System-Light (ASAS-Light), will provide technical control to the systems and analyze the reports generated by the Prophet operator. Prophet Control will interoperate with the ASAS Remote Workstation at a brigade or armored cavalry unit. Prophet Block II will add an Electronic Attack capability. Blocks III-V will add coverage of additional signal types by the Electronic Warfare Support and Electronic Attack systems and new sensors. Development of Block III will likely precede Block II because a new receiver that will be part of Block II is necessary before proceeding with the development of the Electronic Attack capability.

The DTSP will provide the capability to electronically map radio frequency emitters on the battlefield and conduct Electronic Attack against targeted emitters. The DTSP consists of two elements: (1) SIGINT and Electronic Warfare payloads for the TUAV; and (2) workstation software that will remotely control the mission payload and display and analyze the data. The workstation software will be hosted on the Distributed Common Ground Station-Army (DCGS-A). DCGS-A will provide reports to ASAS in the Analysis and Control Element (ACE) at division.

## **BACKGROUND INFORMATION**

The concept for the PROPHET program was initiated in 1998, following unfavorable results from the DT and the Combined DT/OT of the Ground Based Common Sensor-Light (GBCS-L). The Army and DOT&E found that GBCS-L was neither effective nor suitable. As a result, the Army

terminated the Intelligence and Electronic Warfare Common Sensor (IEWCS) program, which included GBSC-L and two other SIGINT/Electronic Warfare systems.

The Army restructured the IEWCS program as the Prophet program. As part of the restructuring, the Army's first step is to field the HMMWV-mounted Prophet as a replacement for the Army's aging tactical ground SIGINT legacy systems: Teammate, Trailblazer, Trafficjam, and the AN/PRD-12. The Army Program Executive Officer (PEO) Intelligence, Electronic Warfare and Sensors is the Milestone Decision Authority (MDA) for both Prophet and DTSP.

### **TEST & EVALUATION ACTIVITY**

Based on the results of a two-phased IOT&E conducted during the 1QFY01, the Army MDA approved production of the Prophet system pending a comparison of the winning contractor's design with the LRIP system configuration that was tested in the IOT&E. This post-contract award comparison is necessary due to a build-to-function vice build-to-model acquisition strategy.

For DTSP, the Army PEO approved proceeding to a Component Advanced Development (CAD) phase and requested that the PM prepare an Evaluation Strategy for submission to OSD. The draft DTSP evaluation strategy is undergoing Army review prior to submission to OSD.

### **TEST & EVALUATION ASSESSMENT**

During IOT&E, Prophet demonstrated the potential to provide accurate and timely force protection information in a low intensity scenario. However, the mid- to high-intensity scenario of the IOT&E strained the ability of the Prophet system, a system that uses no computer-assisted aids and voice reporting, to provide accurate and timely reports. As a result, the winning contractor has proposed to add a man-machine interface, and digital message preparation and reporting in the production system, based on ASAS-Light. Since the Prophet that was tested during IOT&E is no longer representative of the production system, the Army will need to conduct additional OT for the production system.

Test planning has been hampered by the lack of approved an Operational Requirements Document (ORD) and Critical Operational Issues and Criteria (COIC). This problem resulted in the late completion of the operational test plan for Prophet, and continues to affect test planning for future blocks of Prophet and for DTSP.

### **LESSONS LEARNED**

Based on test experience with the Intelligence and Electronic Warfare Common Sensor program, the Prophet operational testing requires a more dynamic and realistic environment than the static developmental testing range configuration that has been used for prior Army SIGINT OTs. DOT&E is coordinating with the Army testers to ensure that operational testing to support each milestone will be conducted in an operational environment as part of field training exercises.

## **RESERVE COMPONENT AUTOMATION SYSTEM (RCAS)**



The Reserve Component Automation System (RCAS) is a scalable, open-systems environment, automated information system that supports commanders with information needed for Reserve Component mobilization and day-to-day administrative operations. It is a sustaining base networked system of workstations, primarily employing commercial-off-the-shelf (COTS) (Microsoft Office® and Windows NT®, JetForms®, etc.) and government-off-the-shelf (GOTS) software applications (Unit Level Logistics System, Standard Property Book System-Redesigned, and Standard Installation/Division Personnel System Version 3, etc.) being developed/deployed in several increments. RCAS will interface with numerous Standard Army Management Information Systems, and certain National Guard and Army Reserve designated standard systems.

### **BACKGROUND INFORMATION**

In 1979, a Mission Element Need Statement was established by the Army for an automated data system to support mobilization of the Reserve Components. The Army Continental Army Management Information System (CAMIS), was begun in the early 1980s, but canceled in 1985. CAMIS was then reprogrammed in 1986 as RCAS under the control of the Chief, National Guard Bureau, with the advice of Congress and the Chief, Army Reserve. The original Mission Need Statement for the RCAS program was approved in September 1988 and the development contract was awarded in 1991 to Boeing Computer Services, Inc. (now Science Applications International Corporation). The first efforts to develop the RCAS had a restriction against the use of hardware and software employed by the active military components, but this was proved non-viable in testing, and in 1995, the program was restructured. The RCAS mission needs were revalidated in April 1996.

Computer hardware was deployed with the first Increment in 1996, and software Increments 1, 2, 3, and 4/5 were operationally tested between 1996 and 2000 in reserve units from the lowest level to the Army National Guard and Army Reserve Headquarters. These increments of RCAS were found effective and suitable, and were approved for fielding.

### **TEST & EVALUATION ACTIVITY**

Increment 6 of the RCAS software was operationally tested in a Limited User Test (LUT) during the period June 27 to July 26, 2001. Test units included the National Guard and Army Reserve

Headquarters, Delaware Army National Guard (DE ARNG) (17 sites) and the 99<sup>th</sup> Army Reserve Regional Support Command, PA and WV (15 sites). The objective of the test was to determine the effectiveness and suitability of RCAS with the addition of Increment 6 software. Primary among the enhancements of Increment 6 software were Force Authorization, Mobilization Planning, Human Resources and Retirement Points Accounting Management Version 2. Regression testing also was conducted of all previous software releases to ensure new software did not adversely affect the system's operation. Continuing evaluations were conducted of an ARNG mobilization activity in Pendleton, OR, August 11-12, 2001; and an ARNG Continuity of Operations Plan (COOP) activity in Oklahoma City, OK, August 21-23, 2001.

### **TEST & EVALUATION ASSESSMENT**

ATEC operationally tested RCAS software Increment 6 in a LUT with follow-on continuing evaluation of mobilization and COOP activities and found it to be operationally effective and suitable. ATEC determined also that RCAS through Increment 6 supports mobilization and COOP activities. DOT&E noted that during Increment 6 OT, several areas (Occupational Health Management, interoperability with external systems, and classified workstation utilization) were acceptable, but limited sample sizes during the LUT did not support desired confidence level in the findings. ATEC agreed to observe these areas with limited sample sizes under continuing evaluation and during Increment 7 testing scheduled for April 2002. DOT&E concurred with ATEC's findings and recommendations and supported the approval of Increment 6 fielding.



## **RQ-7 SHADOW 200 TACTICAL UNMANNED AERIAL VEHICLE (TUAV) SYSTEM**

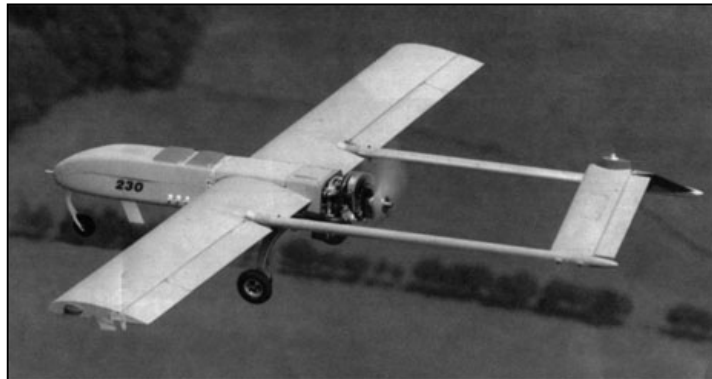

The Tactical Unmanned Aerial Vehicle (TUAV) system is designed as a ground maneuver commander's primary day/night reconnaissance, surveillance, target acquisition, and battle damage assessment system.

The Shadow 200 is a small, lightweight, tactical UAV system. The system is comprised of air vehicles, modular mission payloads, ground control stations, launch and recovery equipment, and communications equipment. It will carry enough supplies and spares for an initial 72 hours of operation. It will be transportable in two high mobility multi-purpose wheeled vehicles (HMMWVs) with shelters, and two additional HMMWVs with trailers as troop carriers.

A single TUAV system includes three Shadow 200 air vehicles with a fourth air vehicle as part of the issued equipment of the maintenance section. The air vehicle is constructed of composite materials, with a wingspan of 12.3 feet, and length of 11.2 feet. Power is provided by a commercial 38-horsepower rotary engine that uses motor gasoline (MOGAS). The payload has a commercially available electro-optic and infrared camera, and communications equipment for command and control and imagery dissemination. Onboard global positioning system instrumentation provides navigation information.

The air vehicle is intended to provide coverage of a brigade area of interest for up to four hours, at 50 kilometers from the launch and recovery site. The maximum range is 125 kilometers (limited by data link capability), and operations are generally conducted from 8,000 to 10,000 feet above ground level during the day and 6,000 to 8,000 feet above ground level at night. The air vehicle uses a pneumatic launcher and is recovered by a tactical automatic landing system without pilot intervention on the runway. The air vehicle is stopped using an arresting hook and cable system.

The TUAV system must provide 12 hours of continuous operations within a 24-hour period. It must be able to surge to 18 hours within a 24-hour period, for up to three consecutive days. The system must be able to keep pace with a brigade's movement, with rapid emplacement/displacement times. An air vehicle may be passed between control stations or launch and recovery stations to facilitate these requirements.

## **BACKGROUND INFORMATION**

In March 1999, the JROC directed the Army and the Navy to pursue separate air vehicle solutions to satisfy their tactical UAV requirements. The JROC subsequently validated the Army's TUAV ORD and three Key Performance Parameters: MOGAS fuel for the air vehicle and generators; day/night passive imagery payload; and C4I interoperability with the Army's Joint Tactical Architecture, Battle Command System, and JSTARS Common Ground Station.

The Army conducted a systems capability demonstration (SCD) in October and November 1999 to establish the baseline for system technical and operational performance and provide input to the TUAV source selection. In December 1999, a low rate initial production (LRIP) contract was awarded to AAI Corporation for four Block I Shadow 200 TUAV systems. In March 2001, a second LRIP contract was awarded to AAI for four more Block I systems. Block I systems do not meet many ORD requirements and the program office has planned for a Block II upgrade, to come closer to meeting TUAV threshold requirements. The JROC-required interoperability with the tactical control system will be integrated as a block upgrade at a later time.

The TEMP was approved prior to Milestone II and the initial contract award. An updated TEMP is currently being drafted for coordination no later than February 2002.

A Milestone III full-rate production decision for the Block I and Block II systems was planned for September 2001. However, due to problems during IOT&E the full-rate production decision is delayed by at least one year. The program will award a third LRIP contract for six more Block I systems. This total LRIP of Block I systems will be 14 of the total 44 required, and the systems would not meet the threshold ORD requirements.

## **TEST & EVALUATION ACTIVITY**

In February 2001, a test event took place at Fort Huachuca, AZ. It was a key risk reduction event to demonstrate a rigorous OP TEMPO similar to that planned for the April 2001 IOT&E. During this OP TEMPO test, the TUAV was to demonstrate the Operational Mode Summary/Mission Profile (OMS/MP). This included five days with on-station times of 12, 18, 18, 18, and 8 hours per day, respectively. The system was operated by a combination of soldiers and contractors. The test was to last for five days and 74 hours of flight. However, a combination of poor weather, an air vehicle crash, and limited air traffic control support extended the length of the test to 21 days.

The Joint Interoperability Test Command (JITC) has periodically assessed the C4I interoperability of the TUAV system with prototype versions of the TUAV ground control station and developmental software. In all, JITC conducted six assessments prior to IOT&E, culminating with the Tactical Operations Center Assessment from February to March 2001, at Fort Hood, TX. The purpose of this test was to assess the interface of the TUAV ground control station with the test unit's (1<sup>st</sup> Brigade of the 4<sup>th</sup> Infantry Division) tactical operations center, through the KPP-required C4I connectivity with Army's Joint Tactical Architecture, Battle Command System, and JSTARS Common Ground Station.

The TUAV system entered IOT&E on April 29, 2001. IOT&E was planned for two phases, each lasting five days. The test scenario portrayed a Kosovo-like peacekeeping environment. The first phase was to measure the capabilities of the system in a more controlled environment to ensure the requisite measures of performance could be collected. Additionally, one subtest was planned to assess the capability of the system to support adjustment of artillery fires. The second phase was more of a free-

play, field training exercise environment in which the Brigade commander could employ the TUAV as required to support his mission. This phase was to provide an opportunity to assess the contribution of the system to the reconnaissance, surveillance, and target acquisition efforts of the brigade. DOT&E approved the TEMP and test plan, and observed the testing.

After two crashes during the first two days of flight, the test was halted pending accident investigations. The test resumed the next week, but was down-scoped to a limited user test (LUT). After two more crashes, the LUT was terminated and all flight operations of the Shadow 200 stopped. Of the more than 150 hours of proposed flight time for the test, 35 hours were executed.

## **TEST & EVALUATION ASSESSMENT**

During the OP TEMPO test, approximately 24 flight hours were completed the first three days. However, the test was interrupted for 11 days. The system flew approximately 66 hours during the last four days with one period of more than 16 hours continuous on-station time. Problems with the air vehicle alternator and fuel bladders were discovered, which ultimately resulted in restrictions on the endurance (less than four hours) and altitudes (less than 10,000 feet) that the air vehicle could fly.

The TUAV system was clearly not ready for IOT&E. Concerns were raised about system reliability throughout the operational test readiness review process, and the certification of system readiness was premature. The program urgently went from contract award to IOT&E in 15 months, having already awarded two LRIP contracts for a total of eight Block I systems.

The OT was not adequately conducted. The brigade did not task the TUAV against instrumented targets as set out by the tester. Additionally, the white cell (simulated division headquarters) did not adequately focus the brigade on the test scenario.

Testing revealed significant system capability problems. The PM imposed landing site constraints on the TUAV platoon regarding width, slope, and amount of debris allowed. Therefore, the landing areas used during the test did not test the ORD requirements or intent of an unprepared, soccer field-sized area, 100 meters by 50 meters. The primary landing area was a hard surface runway. The alternate landing site had to be prepared with corps-level engineering assets. Both landing strips were considerably larger than required. Requirements for optimized landing sites could negatively impact a maneuver commander's employment of this system.

Other deficiencies included target location errors in excess of 200 meters (the threshold requirement is 80 meters), inadequate procedures to support artillery adjustment, and poor reliability (less than three hours mean time between system aborts while the requirement is 20 hours). Additionally, air vehicle susceptibility to detection was high. It was seen and heard within effective ranges of threat systems such as the ZSU-23-4, SA-7, and SA-9. It was also detected by threat radar systems (SA-8 and Giraffe).

The JITC interoperability test report stated that the Block I TUAV ground control station did not demonstrate interoperability with the Army Battle Command System (ABCS), particularly the All Source Analysis Remote Work Station (V 4.3.5) and the Advanced Field Artillery Tactical Data System (98), or the JSTARS Common Ground Station (V 2). By the next IOT&E, the test unit will be using more advanced versions of this ABCS software. This makes achieving interoperability with the TUAV high-risk since the TUAV has yet to interoperate with currently fielded versions of ABCS. Further, JITC cannot certify the TUAV with the advanced versions of ABCS until they are operational and fielded.

The Army established entrance criteria for the next IOT&E that included successful completion of another OPTEMPO test event. To that end, the PM recently conducted a three-phase OPTEMPO demonstration between October and December 2001. The first phase was conducted from October 1-5. While not under operational conditions, the system demonstrated the capability to remain on-station for 12 hours per day for three consecutive days. The second phase took place from November 4-8 to demonstrate system reliability by flying the five-day operational mode summary/mission profile under more operationally realistic conditions. Four air vehicles flew over 112 hours during 28 flights. The mean time between system aborts was 21.3 hours. This is a major improvement over the last IOT&E, lowering risk for the next IOT&E. The third phase, intended as an important data collection and system performance event, was severely curtailed due to inclement weather. Therefore, the results from the November OP TEMPO event were used to support the third LRIP decision.

## **SECURE, MOBILE, ANTIJAM, RELIABLE, TACTICAL TERMINAL (SMART-T)**

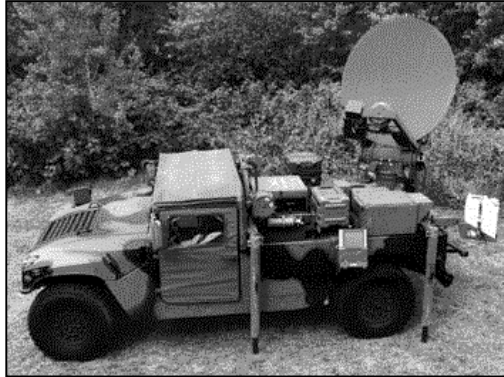

The Secure, Mobile, Anti-jam, Reliable, Tactical Terminal (SMART-T), a MILSTAR satellite communications transmit-and-receive terminal, is a core element of the Joint Service ground terminal segment of the MILSTAR satellite system. The primary SMART-T mission is multi-channel, near-global extended range connectivity for the Army's Mobile Subscriber Equipment, which is the primary tactical communications equipment for corps and division operations. Operating at both the MILSTAR low and medium data rates, it is designed to provide tactical commanders with secure, jam resistant, extended range, two-way, point-to-point and network voice, data, and video communications. In addition to overcoming the limitations of terrain masking and distance, the SMART-T is designed to operate and survive in severe electronic warfare and nuclear, biological, and chemical environments.

### **BACKGROUND INFORMATION**

The SMART-T entered the EMD phase in May 1992, and the low-rate initial production phase in February 1996. The SMART-T acquisition strategy was designed to deliver terminals in advance of the first medium data rate (MDR) MILSTAR satellite being placed in orbit. The Program Office executed the first of three planned SMART-T full-rate production options in January 1999, based on IOT&E results. Further production options beyond the current 89 terminals were to be supported by additional operational tests in 4QFY99 using an on-orbit MDR satellite. However, the April 30, 1999 launch of the MILSTAR Flight 3 satellite failed and the Reliability Growth Testing (RGT) was behind schedule. The second production option will be supported by an FOT&E that was conducted in September 2001 using Flight 4, the first Medium Data Rate (MDR) satellite.

SMART-T IOT&E was conducted June 1-12, 1998, at Fort Gordon, Georgia, using eight production-representative terminals. The test used an on-orbit MILSTAR satellite for Low Data Rate (LDR) communication and the Massachusetts Institute of Technology (MIT)/Lincoln Laboratory MDR/LDR satellite simulator for MDR communications. SMART-Ts were deployed replicating a typical division and corps Army Common User System. There were two major limitations to SMART-T IOT&E:

- As there was no MDR-capable MILSTAR satellite on orbit, the MIT/Lincoln Laboratory satellite simulator was used to emulate MDR communications. The satellite simulator does

not replicate all the physical acquisition and tracking characteristics of an orbiting satellite, nor does it replicate the delay times or footprint associated with an orbiting satellite.

- The Automated Communications Management System (ACMS), an objective communications management tool used for MILSTAR network planning and management control, was not available during the test. An interim planning tool was used to do the network planning for IOT&E. ACMS is still under development but the Army presently is fielding the SMART-T with the Milstar Communications Planning Tool – Integrated (MCPT-i), an interim, less capable tool developed in parallel with ACMS.

The on-board SMART-T diesel generator successfully demonstrated its required reliability of 500 hrs MTBF at 80 percent LCL during RGT in the fall of 1999.

Cold weather setup/teardown testing of a SMART-T was conducted at the Cold Region Test Center (CRTC), Fort Greely, AK, November 8-18, 1999. Thirteen setup and teardown sequences were successfully performed. This test successfully demonstrated that SMART-T can be setup and torn down by a two-man crew wearing cold weather gear, within the 45 minute ORD requirement.

### **TEST & EVALUATION ACTIVITY**

The Program Manager conducted a RGT in FY01 to substantiate the improvements made to SMART-T since IOT&E and to satisfy FOT&E entrance criteria.

SMART-T FOT&E was conducted September 17-25, 2001 at Fort Hood, Texas, using 12 operational terminals. The test used Milstar Flight 4, which is the first MDR on-orbit satellite. SMART-Ts were deployed along with Mobile Subscriber Equipment, the Army Common User System at echelons corps and below. The test was designed to evaluate operational effectiveness and suitability during simulated Army field deployments and maneuvers. FOT&E demonstrated that SMART-T is effective with several minor limitations – message receive rate was 87% versus the required 90% and the current mission planning tool does not provide nuller visibility. FOT&E demonstrated that SMART-T is partially suitable, but great improvements have been made in this area. MTBOMF was estimated at 264 hours (80% confidence level) – still below the 700 hour requirement but well above the 37 hours demonstrated during IOT&E. Other areas for improvement in suitability are Integrated Logistics Support, MANPRINT issues and training. SMART-T has satisfactorily demonstrated that it is survivable.

### **TEST & EVALUATION ASSESSMENT**

DOT&E reported the results of the June 1-12, 1998, IOT&E in our B-LRIP report to Congress in January 1999.

Substantial improvements have been made to the system since IOT&E and the 1999 B-LRIP report to Congress, in particular, with respect to reliability and maintainability. However, operational testing revealed a number of deficiencies that were not identified during developmental testing. The Program Office has identified fixes for most of these deficiencies, and is developing a ‘way-ahead’ plan to implement them. DOT&E supports conditional materiel release pending verification of correction of remaining deficiencies.

## STINGER RMP MISSILE



The Stinger missile is the Army's system for short-range air defense. It provides the ground maneuver commander with force protection against low-altitude airborne targets, such as fixed-wing aircraft, helicopters, unmanned aerial vehicles, and cruise missiles. The Stinger is launched from a number of platforms: Bradley Linebacker, Avenger on High Mobility Multi-Purpose Wheeled Vehicle (HMMWV) and helicopters, as well as the Man-Portable Air Defense configurations.

There are two upgrades to the Stinger-Reprogrammable MicroProcessor (RMP) missile to correct known operational deficiencies of the original Stinger-RMP missile system. The first upgrade, called Stinger-RMP Block I, made software and hardware changes, including a new roll frequency sensor, a small battery, and an improved computer processor and memory. It is currently in the Army and Marine Corps inventory. The second upgrade, Stinger-RMP Block II, added an advanced imaging array infrared (IR) seeker and additional signal processing software. The Stinger-RMP Block II missile was intended to provide improved performance against targets in clutter, more advanced stealthy cruise missiles, unmanned aerial vehicles (UAVs), and suppressed helicopter targets, as well as improved performance during nighttime operations.

### **BACKGROUND INFORMATION**

Operational deficiencies were discovered during testing of the Stinger-RMP missile in the late 1980s. The Secretary of Defense directed the Army to correct the deficiencies and then operationally test the fixes. In 1990, DOT&E approved the operational test plan. The Stinger-RMP missile test program was suspended during Operation Desert Storm, and the missile was rushed into the field. After the Gulf War, the Army proposed a two-phase upgrade program: Stinger-RMP Block I and Stinger-RMP Block II, as described above. Subsequently, the Army conducted tests on the Stinger-RMP Block I without DOT&E approval because the test firings were only conducted within the inner-half of the engagement envelope, not always by the soldiers, not against multiple and maneuvering targets, limited to one firing at night, and after a countdown that predetermined the engagement parameters. Fifteen developmental test firings were conducted between 1993 and 1996 to verify Stinger-RMP Block I hardware and software improvements.

In 1999, the Army prepared the Stinger-RMP Block II program for a Milestone II decision in 1QFY00; DOT&E worked with the Army in developing a test strategy. The activities accomplished

included the approval of an updated Operational Requirement Document, an updated System Threat Assessment Report, and new Critical Operational Issues.

The Army proposes to field more than 13,000 Stinger-RMP Block I missiles. These missiles will remain in inventory until at least 2020. There were also plans to produce approximately 11,000 Stinger-RMP Block II missiles. The Army canceled the Stinger-RMP Block II missile program in early FY00. However, there have been indications that the Army is planning to go ahead with incorporating the focal plane array IR seeker into the Stinger RMP missile.

As a separate but related issue, Congress has urged the Army to evaluate the Air-to-Air advantages and disadvantages that Stinger RMP Block I and the British Starstreak missiles provide for the AH-64 Longbow Apache. This comparative analysis will include live Stinger and Starstreak shots off the Apache helicopter.

### **TEST & EVALUATION ACTIVITY**

All T&E activities on the Stinger-RMP Block II program were suspended when the Army canceled the Block II program. However, there had been an effort initiated to incorporate the focal plane array IR seeker in the Stinger missile.

Planning for the Stinger/Starstreak tests continued this year. Integration and pre-test activities are currently ongoing at multiple locations. Starstreak firings for safe separation, envelope expansion, and captive flight trials for tracking are scheduled for 2-3QFY02. This will be followed by Stinger firings for system readiness and then side-by-side firings to be conducted beginning in 4QFY02.

### **TEST & EVALUATION ASSESSMENT**

DOT&E believes that the currently fielded Stinger-RMP Block I missile was not adequately tested, because the test conditions were not representative of how the missile would be fired in combat. Thus, modifications to resolve known RMP baseline operational deficiencies were not verified and the Block I effectiveness and suitability remains unknown.

As a result of the Stinger-RMP Block II missile system cancellation, the following significant operational shortfalls, which affect the Army's ability to conduct short-range air defense, remain with this system: (1) limited operational capability to defeat the growing threat of UAVs and cruise missiles; (2) limitations remain against helicopters and fixed-wing aircraft that have more sophisticated countermeasures or that may operate in a clutter environment; and (3) diminished effectiveness of the forces equipped with Stinger missiles during night operations.



**SUITE OF INTEGRATED INFRARED COUNTERMEASURES AND  
COMMON MISSILE WARNING SYSTEM (CMWS, AN/AAR-57)  
(SIIRCM/CMWS) INCLUDES: ADVANCED THREAT INFRARED  
COUNTERMEASURES (ATIRCM, AN/ALQ-212)**

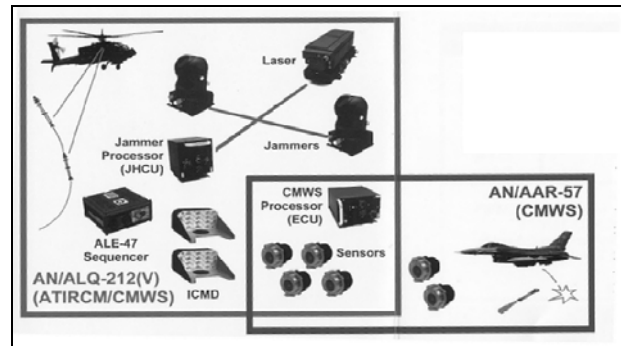

The Suite of Integrated Infrared Countermeasures (SIIRCM)/Common Missile Warning System (CMWS) enhances individual aircraft survivability against an increasing worldwide proliferation of advanced infrared (IR) guided missiles. The SIIRCM concept of IR protection includes new IR flare decoys, the Advanced Infrared Countermeasures Munitions, and passive IR features. These passive IR features include host platform modifications such as engine exhaust/heat suppression and special coatings intended to reduce the platform IR signature. Advanced Threat Infrared Countermeasure (ATIRCM) is a sub-set of the SIIRCM program, and is specifically comprised of an active IR jammer and the passive CMWS.

The ATIRCM/CMWS design is modular to allow multiple configurations on a wide range of aircraft and other vehicles. The Army's lead platforms for EMD are the MH-60K and the EH-60. Two ATIRCM laser jam heads are the normal configuration for some helicopters and one ATIRCM jam head is now planned for tactical helicopters. CMWS is a software re-programmable system intended to provide automatic passive missile detection, threat declaration, positive warning of a post-launch missile that is homing on the host platform, countermeasures effectiveness assessment, false alarm suppression, and cues to other on-board systems such as expendable countermeasures dispensers. For the helicopter applications, the ATIRCM adds active directional countermeasures via an arc lamp and laser. ATIRCM is required to demonstrate integration with the Army's Suite of Integrated Radio Frequency Countermeasures (SIRFC).

**BACKGROUND INFORMATION**

The SIIRCM/CMWS is a Joint Service, Army lead program. In January 1995, the USD (AT&L) approved the merger of the Army ATIRCM program with the Navy/Air Force Advanced Missile Warning System program. The program entered EMD in September 1995. After expanding the EMD Critical Design Review process, experiencing delays in initial EMD hardware/software production, and adjusting detailed T&E planning, the Acquisition Program Baseline schedule was approved in June 1997, moving the MS III from August 2000 to September 2001. The Operational Requirements Document was also changed in FY97 to include a more realistic threshold-to-objective range for ATIRCM effectiveness.

DOT&E approved a TEMP update in November 1998. Additional developmental delays have changed the MS III date to 2QFY03. A Limited Rate of Initial Production (LRIP) decision in April 2002 has been added to the program. An Operational Assessment, to be conducted in early 2002, is designed to provide data to support the LRIP decision. Until this year, CMWS was to be used on both helicopters and fixed wing aircraft. However, funding constraints have led the Air Force to drop out of the program. Therefore, for the immediate future, the only application of ATIRCM/CMWS will be on Army helicopters. The Air Force will assist the Army in conducting fixed-wing (QF-4) tests that are crucial to obtaining data for the modeling and simulation (M&S) program, and to provide data to evaluate CMWS performance on high speed, fixed-wing platforms in the event the Air Force and/or the Navy decide to use CMWS in the future.

During FY01, the program manager decided to make a change in the CMWS hardware configuration. All of the T&E was planned using the EMD version of CMWS. In parallel, the United Kingdom is buying a productionized version of CMWS that is claimed to have better performance, fewer parts, and greater reliability. Although the EMD version of CMWS has performed well, the PM decided that the cost, reliability and performance advantages of a production design upgrade (PDU) version of CMWS were sufficient to warrant a change late in the test program.

## **TEST & EVALUATION ACTIVITY**

Considerable testing and evaluation was accomplished in FY01, i.e., false alarm tests at Eglin AFB in January-February (DT), live fire tests at the Aerial Cable Facility (ACF) at White Sands in April (DT/OT), captive seeker tests at Fort Huachuca in May (DT/OT) and the sled test at Holloman in July. The false alarm tests were conducted with the ATIRCM/CMWS system integrated into an EH-60 helicopter combined DT/OT test period. It was among the most comprehensive tests conducted to date for an IR countermeasures system. The false alarm susceptibility of most all battlefield false alarm sources (e.g., JP-4 fires, 120mm cannons, 30mm guns, arc welders, wingman flares) was determined for the system. More realism was injected into these tests by using the Super Multi Spectral Electro Optic Simulator (SMEOS), which allowed simulated missiles to be fired during the time that the false alarm sources were activated. The false alarm signatures were recorded using calibrated radiometers. These signatures were then used to update the end-to-end model that has been developed for the system. The ATIRCM/CMWS demonstrated a low susceptibility to most of the battlefield false alarm sources.

Twelve shots of four different missile types were fired at the Aerial Cable Range (ACR). The ATIRCM/CMWS successfully countered all shots. Similarly, with the system integrated on the MH-60 helicopter, ATIRCM/CMWS demonstrated effectiveness against all the missile seekers used during the test. Also, IR jammer effectiveness was demonstrated during the sled tests. The EMD model CMWS was the primary missile warning sensor used for all these tests. The CMWS PDU version was incorporated into the ACR tests. Also, the PDU and EMD CMWS versions were checked in side-by-side performance tests at the Wright Patterson Laser Laboratory. In addition, the PDU is being evaluated in the BAE Hardware in the Loop (HITL) facility. The PM conducted an abbreviated false alarm test at Ft Rucker on an MH-60 helicopter.

Hardware-in-the-Loop modeling capabilities are essential to providing an assessment of the operational effectiveness and operational suitability of the ATIRCM/CMWS system. Actual missile firings and drone target requirements have been reduced from nearly 400 to 175 events by developing new T&E concepts that rely heavily on M&S. A major step towards achieving this capability was realized in FY01 with the successful demonstration of the contractor's HITL facility. The system is now

being used in to predict the drone shots planned on the CMWS equipped QF-4 drone, scheduled for the 2QFY02.

## **TEST & EVALUATION ASSESSMENT**

The ATIRCM/CMWS has demonstrated reasonably good effectiveness to date. The tests have shown the need to modify the software for certain operational conditions, and these modifications need to be re-evaluated during subsequent testing, especially with live fire shots at the aerial cable facility. Testing to date has surfaced some suitability problems with the IR jammer. Although effective, several reliability problems were experienced during the open air testing as well as during the reliability development growth test (RDGT) that was started in April 2001 and stopped in August 2001. The jam head will require the re-design of several of its mechanical components. The program office plans to fix these problems during LRIP (scheduled for January 2002), then re-test the system in the 3QFY02 and include additional RDGT tests. A robust DT of jam head changes prior to IOT&E should be done and the IOT&E should include completion of PDU sensor tests. The PDU version of CMWS has demonstrated equal or better performance over the EMD CMWS in the ACR and laboratory tests. To date, the results of the false alarm tests at Ft. Rucker have not been evaluated.

Modeling and simulation are critical elements of the test and evaluation program because the matrix of potential missile-aircraft interactions to be evaluated would require a substantial increase in the number of test firings. The development of the end-to-end model has progressed this past year to the point that it now can be used for test predictions and some scenario evaluations. However, it is yet to be completely verified, validated, and accredited for use in operational evaluation. Without a properly validated and verified HITL, DOT&E does not believe the M&S methodologies developed by the Project Office will be credible.

The operational configuration for tactical helicopters calls for only one ATIRCM jam head on top of the platform behind the rotor (two jam heads are to be used for transports and large helicopters). The single jam head configuration, for tactical rotary-wing aircraft, may not ensure complete 360 degree defensive protection when the single jam head is masked by the aircraft fuselage.

This Page Is Intentionally Left Blank

## SUITE OF INTEGRATED RADIO FREQUENCY COUNTERMEASURES (SIRFC) AN/ALQ-211

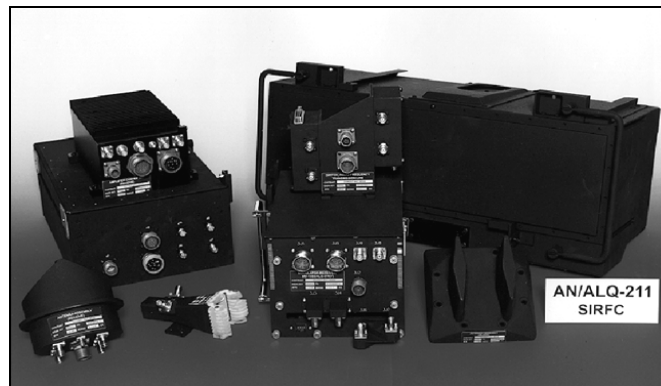

The Suite of Integrated Radio Frequency Countermeasures (SIRFC) is intended to be an integrated aircraft survivability system that provides defensive, offensive, active, and passive countermeasures to ensure optimum protection for the host aircraft. This system will be integrated on the AH-64D, MH-60K, and MH-47E helicopters and the CV-22 and U-2 fixed-wing platforms. The lead aircraft for SIRFC integration and test and evaluation is the AH-64D Longbow Apache. Subsequent host aircraft platforms will undergo FOT&E to assess unique platform integration effectiveness and suitability issues. SIRFC consists of two required sub-systems: the Advanced Threat Radar Jammer (ATRJ) and the Advanced Threat Radar Warning Receiver (ATRWR). The Advanced Airborne Radio Frequency Expendables package and the Escort Stand-Off variant are two system optional components that are currently unfunded. The system provides warning (situational awareness), active jamming (self-protection) and, when necessary, expendable countermeasures to defeat threat radar guided weapon systems. Future integration of SIRFC with the Suite of Integrated Infrared Counter Measures (SIIRCM) on aircraft, which may be equipped with both systems, is a program objective that optimizes multi-spectral threat countermeasures. From this point on, when the name SIRFC is used, it will refer specifically to ATRJ and ATRWR, which are major sub-systems under this program's development.

### **BACKGROUND INFORMATION**

SIRFC achieved Milestone II in 1QFY95, resulting in an EMD contract to produce five test articles supporting T&E through IOT&E. The program underwent an acquisition plan restructure in FY00 to allow for correction of problems discovered in early testing and to better accommodate program milestones and execution of allocated program funding. An LRIP decision is planned for June 2002, with Milestone III scheduled for FY04.

The first EMD test articles were delivered in FY99 and installed on the AH-64D Longbow Apache for integration testing. Upon SIRFC installation on the AH-64D Apache, the test team encountered several integration performance problems with the Operational Flight Program (OFP) software. The most significant of these problems surfaced during 1QFY00 developmental testing at the Benefield Anechoic Facility (BAF) at Edwards AFB, CA. The purpose of BAF testing was to evaluate SIRFC's integrated system performance as installed on the test platform. Aircraft platform testing at BAF included threat identification and prioritization, evaluation of deployment of jamming techniques, performance against both single and multiple emitters (system loading), and measurement of Angle of

Arrival accuracy. During this testing, the SIRFC system revealed significant performance problems handling threat emitters in a dense signal environment. These problems led the Program Manager to stop test efforts on the AH-64D until integrated performance issues could be resolved. An additional year was inserted into the EMD Phase to allow time in the schedule to sufficiently analyze discovered deficiencies, develop and implement corrections, and properly evaluate OFP software performance.

### **TEST & EVALUATION ACTIVITY**

The BAF tests were repeated in January 2001 using the same test plan as in the earlier test. Results were significantly improved with no major deficiencies noted. The BAF tests were followed by contractor flight tests to further mature the system. Government developmental flight tests were conducted in July and August and a Limited User Test (LUT) commenced in September 2001, with completion scheduled for late October. The results of the government DT and the LUT will be evaluated and reported in a system assessment that will support the LRIP decision.

### **TEST & EVALUATION ASSESSMENT**

The SIRFC Program Manager concluded that the previously promulgated test and evaluation schedule did not allow for adequate time to resolve unknown technical problems commonly encountered during the development of electronic warfare programs. Although "box-level" performance in the contractor's test facility was adequate in assessing performance in a controlled laboratory environment, it did not sufficiently evaluate system performance in a dynamic, multiple emitter environment that heavily tasks and stresses OFP software. The integration problems encountered during initial testing at BAF provided the necessary data to support the Program Managers' actions to restructure the EMD phase of the program to include more effective developmental testing. Further integration problems unique to the airborne environment were encountered early in the flight test program. This resulted in continuous modifications being made throughout both contractor and government DT flight tests and the system entered the LUT less mature than desirable. Nevertheless, the LUT was considered a valuable opportunity to gather more information on system operation and to further mature it. Problems discovered during the LUT are being investigated.

## **TOW FIRE AND FORGET (TOW-F&F)**

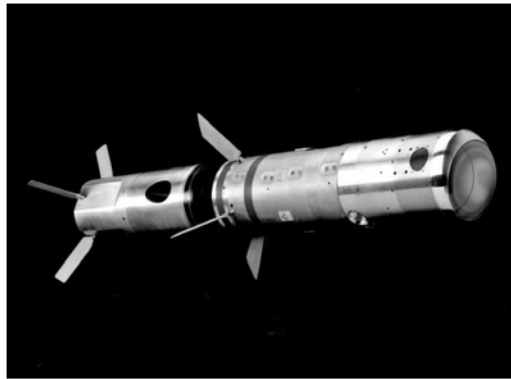

The Tube-launched Optically-controlled Wireless-guided (TOW) Fire and Forget (F&F) anti-tank missile system includes the TOW F&F missile and its associated High Mobility Multi-Purpose Wheeled Vehicle (HMMWV) integration appliqué kit for compatibility with the TOW Improved Target Acquisition System (ITAS). The missile is intended to be a wooden-round, that is, not be maintained by troops in the field. The ITAS provides target tracking and guidance commands to the missiles in the commanded mode. Relative to HMMWVs currently equipped with the baseline TOW missile, the TOW F&F is intended to improve effectiveness and survivability through a fire-and-forget capability that does not require the gunner to guide the missile through its flight. A back-up alternative wireless command-guided mode was required to improve the ability to engage targets in conditions that prevent lock-on in the fire-and-forget mode. The program includes modification of current TOW ITAS training devices to add the characteristics of the TOW F&F.

The Army cancelled the TOW-Fire and Forget Program on November 30, 2001.

### **BACKGROUND INFORMATION**

For the light, early entry forces equipped with the HMMWV-mounted ITAS, the TOW F&F is designated an interim missile system. It is intended to bridge the gap between the aging TOW 2A and TOW 2B missiles currently in the stockpile and the Common Missile, conceptualized to be deployed around 2010. The TOW F&F acquisition strategy capitalizes on reuse of existing TOW 2B components, e.g., rocket motors and warheads, from missiles currently in the stockpile.

### **TEST AND EVALUATION ACTIVITY**

Soldiers examined prototype hardware configurations as part of the early user involvement in FY01. No other formal testing has been initiated.

DT, OT, and LFT&E strategies were incorporated into a TEMP to support Milestone II and subsequent contractor selection. Planned operational testing events include a Limited User Test in FY03 and an IOT&E in FY04. The LFT&E program, spanning FY02 to FY05, includes three phases that will begin with warhead testing and then progress through end-to-end firings against representative tank targets.

OSD approved the TEMP on May 2000 with the provision that it be resubmitted after contact award so that contractor technical choices could be integrated with the test program described in the TEMP. The TOW Fire and Forget LFT&E program, spanning FY02 to FY05, includes three phases that will begin with warhead testing and then progress through end-to-end firings against representative tank targets.

## **TEST AND EVALUATION ASSESSMENT**

A DOT&E's major concern with the TOW-F&F TEMP draft is the relationship between modeling and simulation (M&S) as a risk reduction endeavor and the desire by the PM to reduce costs and minimize missile flight tests through the use of M&S to complement or supplement operational effectiveness and suitability assessments.

DOT&E also is concerned that the upgraded TOW training devices will not adequately match the actual TOW F&F missile launch signature and long range. One of the key lessons learned from the Javelin OT&E experience was that high-fidelity training equipment must be developed, tested, and assessed prior to the IOT&E to support better troop training of anti-armor gunners (this applies to the IOT&E as well as to the normal pre-combat training). High-fidelity equipment is also required to ensure accuracy in scoring force-on-force target kill effectiveness in the IOT&E and for subsequent force-level training opportunities. If the training devices do not faithfully emulate the performance of the real system, then there is the potential for significant negative training by soldiers preparing for combat. Additionally, poor emulation by the training devices could unduly compromise any performance comparisons of TOW F&F to predecessor systems in force-on-force exercises during operational tests.

Finally, DOT&E believes that missile reliability maintenance and testing over its 10-year shelf life warrants additional emphasis, especially since the cost of the TOW F&F missiles will severely limit test articles and essentially eliminate post-fielding firings of live missiles.

The TOW F&F LFT&E program will couple existing lethality test data with the results of planned end-to-end missile firings against threat tank targets in OT. Because the fired missile selects its own hit point, this approach allows for the most realistic hit point selection for lethality evaluation. However, the number of such firings against threat targets is relatively small, so even a few misses could cause a loss of data. Backup firings and the use of a multi-phase test approach will mitigate this risk.



## TRANSPORTATION COORDINATORS' AUTOMATED INFORMATION FOR MOVEMENT SYSTEM II (TC-AIMS II)



The Transportation Coordinators' Automated Information for Movement System II (TC-AIMS II) addresses critical shortfalls in the movement of materiel and personnel in support of DoD operations. It merges the best business practices of the current Service-unique transportation automated information systems into a single system that combines the requirements for the Unit Movement, Installation Transportation Office/Transportation Management Office, and Theater Distribution functional areas, and integrates several legacy systems of the four Services. TC-AIMS II improves joint capabilities for rapid worldwide deployment and reduces "buildup time." It enables rapid crisis response at unit and installation transportation offices. It allows the direct delivery of tailored logistics and sustainment packages at the strategic, operational, and tactical level of operations.

### **BACKGROUND INFORMATION**

TC-AIMS II is intended to be a standard joint system sufficiently flexible to meet Service-unique requirements that will be developed and fielded in functional blocks. The Joint Requirements Oversight Council approved the Operational Requirements Document in March 1999. This document was updated to include specific interoperability requirements.

During joint exercise Foal Eagle 99, a TC-AIMS II prototype was used to manage the deployment equipment list, create military shipping labels, and utilize advanced identification techniques to facilitate in-transit visibility during deployment and redeployment of U.S. Marine and Army units. ATEC, the independent OTA, conducted an OA during the exercise, but results were not encouraging. The software was immature and had not undergone adequate DT.

Software Qualification Testing was conducted during FY00, but as the scheduled OT&E of the Unit Movement functionality (Version 3.01) approached, it became clear that the software still was not mature and that many user requirements had not yet been met. The OT&E was changed to a Customer Test, which ATEC conducted from July 19-August 30, 2000, at four Service test sites: Ft. Hood, TX; Shaw AFB, SC; Gulfport, MS; and Camp LeJeune, NC. Although the results were favorable in some respects, none of the Services were able to complete a transportation planning, coordination, and execution scenario from end to end. It was apparent that significant development was still needed.

## **TEST & EVALUATION ACTIVITY**

The TEMP was approved by DOT&E on November 7, 2001. The OT for Version 3.01 was conducted during November and December 2001 at four test sites, one from each Service: Shaw AFB, SC (Air Force); Amphibious Base, Little Creek, VA (Navy); Quantico, VA (Marine Corps); and the Heidelberg, Germany area (Army). The testing in Germany encompassed users from both U.S. Army Europe (USAREUR) and U.S. Army Forces Command. MCOTEA is conducting the Marine Corps portion of the IOT&E. ATEC, the lead OTA, conducted the testing at the other Service sites and will provide the overall evaluation.

## **TEST & EVALUATION ASSESSMENT**

Although the OT has been completed at the test sites, the evaluation of the test data will not be available until March 2002. However, it is clear that the lack of a joint transportation process has caused development problems. Despite substantial progress in defining joint requirements, the Services still have processes that are different enough to preclude effective “one size fits all” software.

In addition, the numerous external system interfaces have presented substantial technical and operational challenges. While TC-AIMS II was designed in accordance with the original interface agreements, many of the interface requirements changed considerably along the way. Some of the legacy interfacing systems do not comply with data standards, were supposed to have been replaced with new systems, or shouldn't have been planned to interface in the first place.

## UH-60M BLACK HAWK



The UH-60 BLACK HAWK is a single rotor medium-lift helicopter that provides utility and assault lift capability in support of the full spectrum of combat and peacetime missions. The BLACK HAWK is the primary helicopter for air assault, general support, and aeromedical evacuation. The BLACK HAWK can also be configured to perform command and control, electronic warfare, and special operations missions.

### **BACKGROUND INFORMATION**

The Army began fielding the UH-60A in 1978. A 1989 power train upgrade resulted in a model designation change from UH-60A to UH-60L. Since 1989, the Army has procured about 539 of the newer UH-60L models, but has not modernized the previously fielded UH-60A aircraft. Procurement of 60 more UH-60L BLACK HAWKs is funded through FY05. Commencing in 2002, the Army plans to recapitalize 193 UH-60A aircraft until these aircraft can be inducted into the UH-60M program in 2006.

The Operational Requirements Document approved in March 2001 establishes a blocked approach to development and modernization. The near-term Block 1 aircraft, the UH-60M, is intended to extend airframe service life while providing a digital cockpit, improved performance, and improved reliability and maintainability (relative to the UH-60A) for the Black Hawk fleet. The Block 2 requirements establish the UH-60X Black Hawk with significantly increased performance and survivability requirements. The Army plans to leverage new engine technology that will provide increased lift capability, while improving fuel efficiency. Survivability of the UH-60X is intended to be enhanced by two systems in development now: the Suite of Integrated Radio Frequency Countermeasures and the Suite of Integrated Infrared Countermeasures; and by improving the ballistic damage tolerance of the fuel subsystem, flight controls, and the main and tail rotor systems.

In May 2000, OSD approved the TEMP for Block 1 (UH-60M) testing of the BLACK HAWK modernization program. In August 2000, USD (A&T) waived the requirement for full-up, system level LFT&E based on an alternate plan approved by DOT&E. Lastly, the TEMP was updated and approved by OSD in 1QFY02.

## **TEST & EVALUATION ACTIVITY**

The Army successfully developed, integrated, and operationally tested a modified UH-60L medical evacuation Black Hawk, the UH-60Q, with a semi-digital cockpit that will be the baseline for the UH-60M configuration. While finding that pilot situational awareness was enhanced significantly, the Army encountered electromagnetic interference problems with the UH-60Q cockpit during developmental testing. Follow-on electromagnetic environmental effects (E3) testing of the UH-60Q should show that subsequent integration and modifications have addressed these E3 problems specific to the MEDEVAC aircraft.

Working in concert with industry, the Army has conducted flight testing of the wide chord blade (WCB) and the advanced flight control computer (AFCC). Both technologies will be installed on the UH-60M. The WCB offers increased lift, range, and speed as well as reduced procurement and maintenance costs compared to the current Black Hawk blades. The dual AFCC, coupled with a new digital Flight Director, will retain current functionality while enhancing aircraft handling qualities, reducing pilot workload, and improving flight safety margins while conducting low speed tactical missions under limited visibility conditions.

The alternative LFT&E plan will be conducted in two phases (static and dynamic). The first phase will consist of ballistic vulnerability tests performed on individual components, while the second phase will address system-level vulnerability. In addition, the LFT&E program will take advantage of ongoing Navy (MH-60R and MH-60S programs) LFT&E activities and will cost-share some of the required testing.

Currently, the program has procured several damaged Army and Navy H-60 family aircraft, and a fully operational, but not flight worthy, prototype YCH-60 that will serve as the ground test vehicle. The availability of these actual components should provide the majority of the hardware required for the conduct of the LFT&E program. First phase ballistic testing was initiated during 3QFY01 and will continue through FY04, while second phase dynamic ballistic testing will begin in 1QFY02 and continue through 4QFY04.

## **TEST & EVALUATION ASSESSMENT**

The primary technical risk for the UH-60M is the digital cockpit. Thus far in developmental testing, the operational benefits of the digital cockpit have not been convincingly demonstrated. In post-flight surveys, pilots believe that digital cockpits improve their own awareness of aircraft status and the tactical situation, but the benefits to the aviation commander and supported units are unknown. The Army has not yet demonstrated effective digital communications. The UH-60M test program will provide ample opportunity to evaluate the effectiveness of the digital cockpit.

The Army tested the WCB on the UH-60A/L last year. Handling qualities were unchanged from those with standard blades with two exceptions.

**Migration of Cyclic Control.** The UH-60A/L with WCBs installed exhibited a left lateral stick migration during turns. The migration was more pronounced in right hand turns at higher loading and steep angles of bank, maneuvers near the edge of the performance envelope. Unless corrected, this deficiency could result in loss of controlled flight when attempting to recover from steep right-hand rolls

in a dive at low altitude. Currently, the program office is conducting a 12-month risk reduction effort that will address this deficiency prior to the UH-60M system Preliminary Design Review (PDR).

**Vibration.** Lateral vibration levels were slightly higher with the WCB installed on UH-60L aircraft than with the standard blades. Testing demonstrated that roll absorbers must be installed for WCB vibration levels to be acceptable. While existing UH-60L roll absorbers corrected for most vibrations, the lateral component of vibration due to WCBs was not fully corrected. To rectify this situation, the UH-60M program will implement an Active Vibration Control (AVC) system in place of the fielded UH-60A/L passive vibration control system. The AVC will provide a lighter weight system and correct the vibration levels to an acceptable level.

The current aircraft design weight barely allows the UH-60M to achieve its external lift requirement. Specific plans for refurbishment of the airframe are yet to be decided. Selection and design of digital cockpit components will be finalized by system PDR. Solutions to the vibration and cyclic control problems induced by the WCB may result in increased airframe structure, and thus increased overall weight. These issues, coupled with the historic weight growth of aircraft programs in development, may degrade aircraft performance to the point that satisfactory demonstration of the external lift requirement may be at risk.

The LFT&E plan takes into account vulnerability reduction features that have been incorporated into the Black Hawk since its initial fielding in 1978. This plan also will use combat damage experience, subsystem qualification efforts, computer modeling and simulation, as well as sister Services' testing on similar aircraft through the H-60 (Army/Navy) Combined LFT&E Integrated Product Team. The initial component testing on the Main Rotor Flight Controls has been completed. The Main Rotor Flight Controls included the main rotor pitch control links and the swash plate, under static flight loads. Actual results are classified but the initial indications are favorable (improved survivability) for the two improved components tested to date.

This Page Is Intentionally Left Blank

# WARFIGHTER INFORMATION NETWORK – TACTICAL (WIN-T)

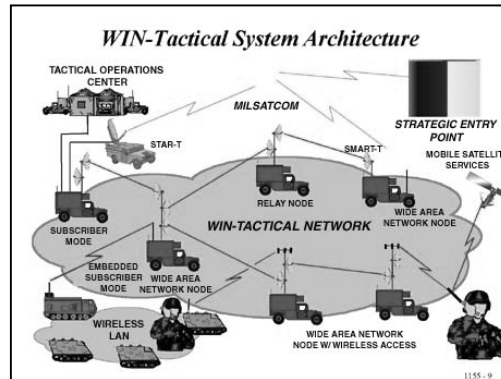

The Warfighter Information Network–Tactical (WIN-T) is the Army's tactical Intranet from theater and the sustaining base to the maneuver brigades as a threshold requirement and maneuver battalions as the objective requirement. WIN-T is the communications network of the future and will replace Tri-Services Tactical Communications (TRI-TAC) and Mobile Subscriber Equipment (MSE). The major WIN-T elements are network infrastructure, network management, information assurance, and user interfaces that provide voice, data, and video services. The four major WIN-T elements, when integrated with the Army's Tactical Internet, form the Army's Tactical Intranet. WIN-T enhances network management capabilities currently provided by the Integrated System Control (ISYSCON).

WIN-T provides wired and wireless communications for voice, data, and video by relying on commercial products and technologies as available. WIN-T supports multiple security levels from Unclassified to Top Secret/SCI. It operates in the tactical environment and is mobile, secure, and survivable. It integrates terrestrial, airborne, and satellite-based transport capabilities into a network infrastructure to provide connectivity across the extended battlespace. WIN-T objective capabilities are integrated into maneuver platforms and deployed with the Warfighter. WIN-T network management, and Wide Area Network (WAN) coverage capabilities, is deployed by Army signal units.

## **BACKGROUND INFORMATION**

The WIN architecture was approved in January 1996, and the first draft Operational Requirements Document (ORD) approved by the Signal Center in April 1998. In early 1999, the program office began OSD briefs, and IPT meetings commenced in May 1999. The current schedule has dual contractors developing the systems architecture beginning 3QFY02 and demonstrating their designs in an Early User Test and Experimentation (EUT&E) event in 2QFY04. A single contractor team will be selected in 1QFY05 to enter a two-year low rate production phase that will be followed by the Initial Operational Test and Evaluation (IOT&E) in 1QFY07. The full-rate production decision is scheduled for 2QFY08.

## **TEST & EVALUATION ACTIVITY**

Due to changes in the POM, many T&E activities have been delayed. The ORD is approved, the Critical Operational Issues and Criteria (COICs) are in draft form, operational test and evaluation

strategies for the System Integration and Demonstration phase are intended to be formalized soon, and the Test and Evaluation Master Plan (TEMP) is expected to begin coordination for final signatures before the end of CY01.

### **TEST & EVALUATION ASSESSMENT**

The IOT&E is planned for 1QFY07 and is expected to test a signal battalion set of equipment in a division-sized or larger operational test. Production Verification Testing is planned to precede IOT&E by one year and will be conducted on a sub-set of the same production representative hardware used in IOT&E.

No technical or operational testing has occurred. Operational test strategies are currently being developed to ensure that the IOT&E will be adequate to determine if WIN-T communications assets can support deployed units from brigade to corps. The intervening year between technical testing and operational testing is well advised to correct any identified problems prior to training of the operational test unit. However, the current schedule does not provide sufficient time between the scheduled Force Development Test and Evaluation (FDT&E) and the IOT&E to retrain units if significant adjustments to tactics, techniques, and procedures are required, or to correct any hardware or software deficiencies. Operational test strategies for testing beyond the full-rate production decision are being developed.

WIN-T is a system where early involvement is being implemented. Participation in Test and Evaluation working group meetings since the program's inception has helped define COICs that are operationally meaningful and measurable for assessing the WIN-T contribution to operations. This early cooperation improves the quality of both the system development and test program and provides meaningful assessments for future decisions.



## WIDE-AREA MUNITION (WAM) ADVANCED HORNET

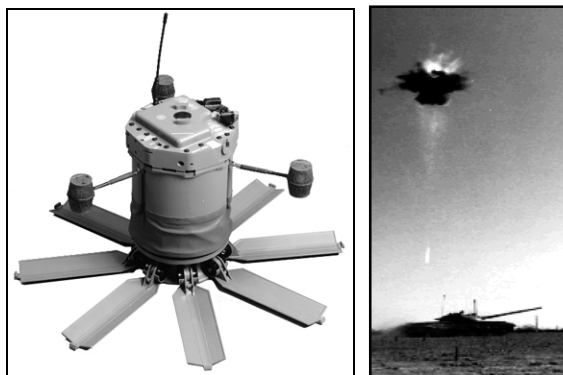

The Wide Area Munition (WAM) is a smart, autonomous top-attack anti-tank munition designed to defeat armored combat vehicles from a standoff distance. It utilizes acoustic and seismic sensors in its ground platform to detect, track, and classify potential targets, and then launches an infrared detecting submunition (sublet) over the top of the selected tracked target. Once a sublet detects a target, it fires an explosively formed penetrator (EFP) to defeat it. Threat target vehicles include tanks, engineer breaching vehicles, and lightly armored tracked vehicles. The variant currently in low-rate production is the Hand Emplaced WAM (HE-WAM), also referred to as the Hornet. It is designed to be carried and emplaced by one person, have a 360 degree, standoff lethal radius of 100 meters and be fully autonomous from final arming to target engagement.

A product improvement of the HE-WAM, called Advanced Hornet, will include two types of improvements. First, communications changes will be made, adding two-way communications with status confirmation, a redeploy-before-arm capability, a safe passage mode, and other features designed to allow networking of emplaced munitions. Second, the current HE-WAM sublet will be replaced by an adaptation of one developed for the Air Force Sensor Fuzed Weapon (SFW) P3I program. HE-WAM is substantially different than the SFW P3I warhead. In particular, the HE-WAM has a single EFP made from tantalum. The SFW P3I warhead uses a multiple-fragment EFP of copper. It uses an active laser rangefinder, in addition to a passive infrared sensor. This warhead will expand the WAM target set to include heavy wheeled vehicles.

### **BACKGROUND INFORMATION**

The WAM Required Operational Capability (ROC) approved in March 1990 envisioned a "Family of WAM" concept of three variants: (1) hand-emplaced; (2) Volcano Scatterable Mine System-delivered; and (3) deep attack Army Tactical Missile System delivered. However, only the hand-emplaced variant has been developed. In September 1996, the Army approved HE-WAM for LRIP and Advanced Hornet entered the EMD Phase of its development. Although HE-WAM was expected to go into full-rate production (FRP) at the end of 1998, the Army opted not to proceed into FRP. DOT&E submitted a Live Fire Evaluation report of HE-WAM to Congress in July 1999. The combination of test activities was adequate to support an assessment of the lethality of HE-WAM against its expected targets and draw some inferences regarding the weapons' effectiveness. In March 2001, the Army gave HE-WAM a Conditional Materiel Release for only 377 units. Work continued on development of the Advanced Hornet system with an anticipated full-rate production decision scheduled for 2004.

In FY00, the DoD IG initiated an investigation of the history, progress, and status of the WAM Program. A draft report circulated for review and comment was critical of the management of the program and recommended an OSD-level program review. As a result, Advanced Hornet was placed under OT oversight by DOT&E in May 2001.

An ORD update incorporated newly required interoperability and more specific command and control, reliability, and operational effectiveness capabilities. The ORD was forwarded for approval in September 2001. Specific target dates for MS C and FRP decisions have not yet been established.

### **TEST & EVALUATION ACTIVITY**

No operational testing of Advanced Hornet was accomplished through the end of 2001. DOT&E has been working with the Army to develop an Advanced Hornet T&E strategy and the operationally realistic test events required to support that strategy. DT will continue into 2002 while specific dates for operational testing are being developed.

There was no LFT&E-related testing in FY01. The Live Fire Integrated Product Team (IPT), however, did conclude that another lethality Live Fire program is required for Advanced Hornet due to the warhead change. The Live Fire IPT, with DOT&E participation, has begun work on an LFT&E strategy. A key data source for LFT&E is expected to be a robust set of end-to-end firings against representative threat targets under varying tactical engagement conditions. Because the Advanced Hornet must have the capability to attack heavy wheeled vehicles, those targets will be included in the test program. The Live Fire IPT will determine whether any of the lethality data from the LFT&E program of the SFW P3I, which is also under LFT&E oversight, are applicable to the Advanced Hornet.

### **TEST & EVALUATION ASSESSMENT**

Although HE-WAM entered LRIP in September 1996 it will never enter full-rate production and no additional operational testing is planned. Advanced Hornet remained in EMD throughout 2001, but no operational assessments of Advanced Hornet communications and warhead improvements were made.

Live Fire Testing of the current HE-WAM against actual threat vehicles demonstrated its lethality when critical areas were struck. The damage inflicted by tower shots generally led to substantial degradation in target mobility (and sometimes catastrophic loss). In contrast, end-to-end firings of tactical HE-WAMs against moving T-72 tanks tended to hit areas at the rear and edges of the targets, where there were fewer critical components. Hence, the warhead was less effective. HE-WAM was not effective out to its required range, and was only marginally effective at half the required range. If the full potential of the warhead is to be realized, improvements are needed in sublet accuracy relative to the critical areas of the targets.

**PART IV**  
**NAVY PROGRAMS**



## **ADVANCED AMPHIBIOUS ASSAULT VEHICLE (AAAV)**



The Advanced Amphibious Assault Vehicle is an amphibious armored personnel carrier that will replace the current Marine Corps assault amphibian - the AAV7A1. Two variants are under development: the personnel variant (AAAV(P)), which will be armed with a 30-mm cannon and a 7.62-mm machinegun, is intended to transport 17 combat-equipped Marines and a 3-man crew, and a command and control variant (AAAV(C)), which will transport a commander and staff. An operationally-configured AAAV will weigh about 37 tons and travel in excess of 20 knots in 3-foot significant wave height water conditions, and at 43 miles per hour over land.

The AAAV is designed primarily to provide an over-the-horizon amphibious assault capability for Marine Air-Ground Task Force elements embarked aboard amphibious ships. Once ashore, the AAAV(P) will be an armored personnel carrier, providing transportation, protection, and direct fire support. The AAAV(C) will serve as a tactical echelon command post.

### **BACKGROUND INFORMATION**

The AAAV program entered the Program Definition-Risk Reduction (PDRR) phase after Milestone I in 1995. In December 2000, the AAAV entered the System Development and Demonstration phase. The current TEMP had been approved by OSD in November 2000. Delays in completing DT and OT have led to a program baseline breach, which is expected to delay the LRIP decision and IOC by approximately one year. A baseline breach necessitates a TEMP update, which DOT&E is supporting through the program's T&E Integrated Product Team; it should be forwarded to OSD for approval in December 2001.

### **TEST & EVALUATION ACTIVITY**

T&E activities during 2001 consisted primarily of DT of the three PDRR AAAV(P) prototypes, including land mobility, water mobility, and firepower testing; these events will continue into FY02.

In addition, MCOTEA performed an EOA using a wood mockup to represent the AAAV(C)'s interior and a representation of the C4I suite comprising mostly COTS surrogates. Communications were simulated using wire connections rather than over-the-air radio transmissions. Marines from II Marine Expeditionary Force acted as elements of a battalion and a regimental staff to assess human factors engineering issues.

The LFT&E Ballistic Hull and Turret (BH&T) test series was begun in December 2000 and completed in July 2001. The fidelity of the BH&T allowed for shock input measurements for various critical components, and limited estimates of vehicle loss of functionality following certain test events.

MCOTEA and the U.S. Army Evaluation Center (AEC) began work on a formal Memorandum of Agreement clearly defining the participation of each in AAV LFT&E. Ballistic Vulnerability (BV) test planning was begun under the guidance of MCOTEA and AEC in July 2001. The recent program acquisition baseline breach will require re-examination of the LFT&E Strategy in the TEMP.

## **TEST & EVALUATION ASSESSMENT**

The procurement of three PDRR AAV(P) prototypes allowed land, water, and firepower testing to proceed in parallel and more efficiently. DT focused on land mobility (for example, braking, acceleration, and negotiating slopes), water mobility (such as speed at different weight conditions), and gunnery. Testing appears incomplete relating to operating in the ocean, transiting surf zones, and operating sequentially in water and on land. However, monitoring DT and its results has been difficult, primarily because information about ongoing DT is not available to DOT&E or MCOTEA in a timely manner. DOT&E has requested that the PM provide access and notification of ongoing DT, which will aid in the future oversight of the OT assessments and testing.

DT has exposed numerous engineering problems, the early discovery of which should lead to an improved design for the ten prototypes that will be constructed during the SDD phase. However, these unexpected engineering challenges and poor prototype reliability have caused DT to fall 9 to 13 months behind schedule, raised questions about design maturity, and impacted the OT test program by delaying the EOA. Continuing to defer the AAV(P) EOA makes it less likely that early OT results will contribute to the SDD prototype design. In addition, the schedule for future DT appears to be unrealistically optimistic in terms of allowing enough time to test, fix, and retest. Despite the fact that more time was needed than was planned for DT of the PDRR prototypes, the current schedule allows only a limited time for SDD prototype DT before the start of the FY04 SDD EOA. Consequently, DOT&E is concerned that the SDD prototypes might not be sufficiently tested before the SDD OA begins. Similarly, there is little time scheduled for DT of the LRIP vehicles that will support the IOT&E.

Data from the DT and OT that have been completed have raised several concerns:

- The AAV's demonstrated reliability has fallen short of reliability growth predictions. In response, the Program Office implemented an aggressive program to determine root causes for these failures and identify corrective actions.
- The KPP to transport 17 combat-equipped Marines has not yet been demonstrated in the water because of the absence of safety certifications.
- To meet strength, weight, and cost constraints, the program office is using the aluminum alloy Al 2519 even though corrosion test results confirm that Al 2519 is less suitable for the marine environment than the aluminum alloy used in existing vehicles.
- The results of the AAV(C) EOA in FY01 were mixed. There did not appear to be significant human factors environment problems. However, attempting to obtain operational insights by exposing the test participants to a simulated C4I suite in a wood mockup was less than ideal. The lack of a fully functional C4I system did not allow an assessment of essential

communications links, and hence situational awareness, however, the test C4I suite configuration was sufficient to determine that integrating the C4I software applications requires more attention.

- Safety and performance-related restrictions reduce what can be attempted in OT. Interior noise levels currently limit the amount of time embarked Marines can remain in the vehicle. Carbon monoxide accumulates in the vehicle during 30-mm cannon firing. The temperature inside the vehicle rises to unsafe levels in high ambient temperatures, restricting troop transport and requiring that some electronic components be cooled with cooling packs to prevent overheating.

In summary, many operationally relevant questions remain unanswered. The AAV(P) has not demonstrated that it can accomplish its primary mission, that is, transport combat-equipped Marines from an amphibious ship located 20 to 25 nautical miles offshore to objectives located inland without degrading their physical condition. Finally, the performance of an integrated AAV(C), the more complicated variant, has still not been demonstrated to DOT&E.

LFT&E of the AAV includes vulnerability evaluation of the vehicle to the broad range of threat weapons described in the AAV System Threat Assessment Report. The test foundation of LFT&E rests upon a BH&T test series in FY01, a BV test series in FY02-03, and a Full-up System Level (FUSL) test series in FY04-05. Other LFT&E testing that will include ballistic testing of representative armor coupons, and subsystem controlled damage testing. Conduct of the BH&T test series contributed substantially to understanding the vehicle armor and structural response to ballistic attack. Several specific unexpected vulnerabilities were identified and design changes will have to be incorporated based on the results of BH&T.

LFT&E of the AAV also includes a lethality evaluation of the 30-mm high-explosive ammunition against the range of expected targets. The Direct Reporting Program Manager, AAA (DRPM) has conducted extensive firing of existing and developmental 30-mm high-explosive ammunition.

Initial planning for the BV test has revealed a shortcoming in the LFT&E Strategy. DRPM-AAA was basing the LFT&E Strategy upon conduct of system-level ballistic testing against a functional and near-production-representative PDRR prototype vehicle early in SDD. The program office had felt that the PDRR prototypes represented a nearly mature design and that this, combined with their availability for early testing, more than offset the elimination of one of the two originally planned FUSL test assets. The PDRR prototypes have proven to be far less mature than anticipated. The future production configuration will incorporate substantial changes in structure, component physical layout and subsystem functional architecture. Adding a second FUSL test asset will allow more efficient use of range time, provide an immediate source of major critical repair parts when necessary, and reduce the scope of repairs to cumulative damage by dividing test events between the two vehicles.

This Page Is Intentionally Left Blank



## **ADVANCED COMBAT DIRECTION SYSTEM (ACDS) BLOCK I**



The AN/SYQ-20 Advanced Combat Direction System (ACDS) Block 1 consists of computer program software and associated hardware for non-Aegis combatant ships (aircraft carriers and selected amphibious warfare ships). ACDS Block 1 provides extended range display, expanded track capacity, Joint Tactical Information Distribution System interoperability, modifiable doctrine, display of mapping information, automatic gridlock, and doctrine-controlled multi-source identification. AN/SYQ-20 hardware includes computers, a display system with consoles, data terminal sets, automatic data processor, and automated status boards.

### **BACKGROUND INFORMATION**

ACDS Block 1 represents the second phase of implementation of the Combat Direction System improvement plan of 1981, with ACDS Block 0 representing the initial phase. OPEVAL was conducted in February 1998 at the Atlantic Fleet and Puerto Rican operating areas. ACDS Block 1 was assessed as neither operationally effective nor operationally suitable. Further OT&E, conducted in FY99, indicated improvement, but ACDS Block 1 was still deficient in several areas. Subsequently, it was determined that ACDS Block 1 will be installed in no more than five ships (USS *John F. Kennedy*, USS *Dwight D. Eisenhower*, USS *Wasp*, USS *Nimitz*, and USS *Iwo Jima*).

### **TEST & EVALUATION ACTIVITY**

During FY01, ACDS Block 1 T&E was conducted as part of the risk reduction T&E for the Cooperative Engagement Capability (CEC) OPEVAL. DT&E was conducted during December 2000. OT&E (OT-IIIE) was conducted in conjunction with the CEC OPEVAL during April and May 2001. Testing was conducted in accordance with a DOT&E-approved TEMP and test plan at the Atlantic Fleet Weapons Training Facility (AFWTF) Puerto Rico and then in the Virginia Capes (VACAPES) Operating Area. The Director observed testing in the VACAPES area. His staff and representatives observed testing at both locations. ACDS Block 1 combat systems were installed in USS *Wasp* and USS *John F. Kennedy*, as well as the land-based test site at Dam Neck, VA, for the VACAPES phase.

## **TEST & EVALUATION ASSESSMENT**

OT-IIE used the test resources that were assembled for the CEC OPEVAL. Since the primary warfare area for CEC is air warfare, the resources were not intended to support other areas of ACDS Block 1 functionality and limited examination of areas such as undersea warfare and surface warfare.

Results indicate that ACDS Block 1 is still neither operationally effective nor operationally suitable. The following critical operational issues were resolved as unsatisfactory: own-ship mission management, composite warfare command management, doctrine management, survivability, reliability, maintainability, logistic supportability, interoperability, human factors, and documentation. It was observed that operation with CEC in conjunction with other ships, although producing enhanced situational awareness and ability to engage targets at greater range, also increased operator workload. The ACDS tactical picture was considered unmanageable as a result of extraneous tracks broadcast over the CEC network. ACDS Block 1 software mean time between faults was below threshold. Moreover, warm start capability did not work, thereby precluding rapid restoration of the tactical picture after software faults. Interoperability between ACDS Block 1 and CEC was unsatisfactory. Critical operational issues that were resolved as satisfactory include performance and casualty modes, availability, compatibility, training, safety, and security. Resolution of the training COI as satisfactory must be accompanied by the observation that ship crews were provided training beyond normal Navy pipeline training, enabling crews to maintain and operate ACDS Block 1.

## ADVANCED DEPLOYABLE SYSTEM (ADS)

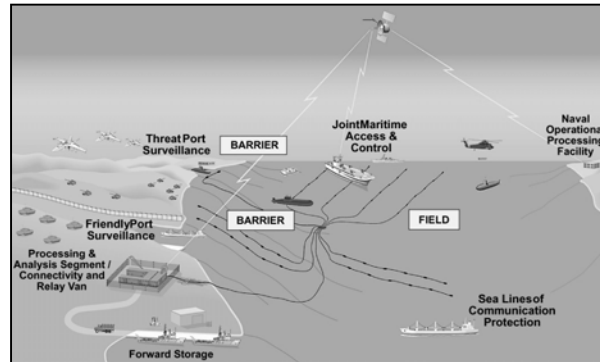

The Advanced Deployable System (ADS) is a littoral water deployable undersea surveillance system designed to provide the Joint Force Commander with a timely and reliable picture of undersea activity. ADS consists of an Underwater Segment, a Processing and Analysis Segment, and a Mission Support Segment.

### **BACKGROUND INFORMATION**

Initial system-level testing of ADS was conducted in March 1998, in an Integrated Article Test designated OT-IA. The arrays were deployed from a towed installation vehicle. Using the Integrated Article Test results, modeling and simulation reviews, and other development tests dating back to 1996, COMOPTEVFOR completed an Early Operational Assessment of ADS in June 1998. This variant of ADS was assessed to be potentially operationally effective. Potential operational suitability could not be determined due to system immaturity. Four significant areas of risk were identified by this Early Operational Assessment: deployment time, joint interoperability, interoperability, and tactics.

An Operational Assessment (OT-IB) was conducted on the ADS system over a 60-day Fleet Exercise Test (FET), in conjunction with various U.S. Third Fleet sponsored exercises between March and May 1999. The craft of opportunity variant of ADS was assessed to be potentially operationally effective and potentially operationally suitable. Three significant areas of risk were identified by this OA: underwater segment survivability, interoperability, and training.

### **TEST & EVALUATION ACTIVITY**

In September 2000, DOT&E observed OT-1C, an operational assessment of a second ADS variant. This was combined DT/OT in conjunction with DT-IE. While the deployment method was physically demonstrated, several technical problems impacted the schedule and ability to assess detection capability. The deployment method for this test was determined to be potentially operationally effective and suitable. Four areas of significant risk were observed: underwater segment survivability, mission planning, reliability, and availability.

DOT&E observed a development test conducted in April 2001 that examined a third ADS variant. COMOPTEVFOR participated in a DT Assist during this test, which demonstrated physical

deployment. Difficulties with cable retrieval techniques and at-sea fiber optic splicing procedures prevented a more comprehensive assessment of the system including detection capability. See the DOT&E 2001 Annual Report Classified Annex for further details regarding this test and OT-1C.

In April 2001, the sponsor restructured the program by reprioritizing the ADS variants in a phased development program. The ORD and TEMP are being restructured accordingly. The draft test strategy calls for operational assessments prior to TECHEVAL and OPEVAL planned for FY04.

### **TEST & EVALUATION ASSESSMENT**

The greatest concern with current ADS deployment options is underwater segment survivability. The array cables are vulnerable to biologics (e.g., fish bites) and the activities of fishing fleets. Survivability of the arrays over the required mission endurance threshold is a major concern due to the potential occurrence of this unintentional damage. Cable burial and greater cable diameter are expected to significantly mitigate this vulnerability. The Navy has selected a larger diameter cable for ADS and is developing a method to bury the ADS trunk cable that links the arrays to the shore site. The capability to bury the entire Underwater Segment will be subsequently developed.

## **ADVANCED INTEGRATED ELECTRONIC WARFARE SYSTEM (AIEWS) AN/SLY-2(V)**



The AN/SLY-2(V) Advanced Integrated Electronic Warfare System (AIEWS) is the Navy's next generation shipboard electronic warfare system planned for use with the Aegis Combat System and Ship Self Defense System Mark 2. It is a total replacement for the AN/SLQ-32(V) system. Increment 1 of AIEWS will include the capability to detect and identify radio frequency (RF) emissions, provide precision angle of arrival information to cue hard-kill fire control system sensors, and launch self-protection decoy devices. Shown in the photograph is a demonstration antenna used during at-sea engineering tests. Integration of Increment 1 with the ship command and decision system will support other sensor cueing and combat identification. Increment 2 will include additional capability.

### **BACKGROUND INFORMATION**

The Navy approved the ORD in April 1997. The initial TEMP was received by OSD in March 1998 and was returned without approval because of the fundamental disconnect between the program structure (as agreed to by the PEO in November 1997) and the program structure reflected in the language of the Milestone II ADM. This was somewhat redressed in FY01 when the OPEVAL was delayed so it could be conducted in an Aegis destroyer with AIEWS more integrated with the combat system.

AIEWS development is behind schedule and the initial installation will still not be fully integrated with the host combat system. For initial installations, AIEWS will use the same interfaces as the system it will replace, the AN/SLQ-32(V) electronic warfare system. As a result of this limited integration, some of the improved capability required of AIEWS cannot be fully used to benefit the combat system. For example, the improved precision angle-of-arrival information will not be available to cue hard-kill fire control system sensors. The program was rebaselined in FY01 as a result of cost and schedule breaches.

### **TEST & EVALUATION ACTIVITY**

This Naval Air Warfare Center, Weapons Division, Point Mugu, CA, integrated and tested an anti-ship cruise missile (ASCM) seeker with an existing target drone to provide a test asset that would partially address inadequacies of proposed ASCM simulators. In December 2000, two BQM-34S drones,

configured with ASCM seekers, were flown to demonstrate operation of the seekers at ASCM-representative speeds and altitudes; collection of seeker data as it detected, acquired, and tracked a surface target; and safe recovery of the seekers. The only objective that was not completely achieved was that the low altitude required was never achieved. Post-flight analysis has indicated the likely cause, and it is projected that this will not be a problem in the future. This demonstration project was conducted under the Target Management Initiative program under the auspices of DOT&E.

## **TEST & EVALUATION ASSESSMENT**

There are no test results of sufficient scope on which a performance assessment can be based. The Increment 1 T&E program will examine critical operational effectiveness issues, including situation awareness (the effective and accurate detection, track, and identification of radio frequency emitters); engagement support (effective employment of decoys against anti-ship cruise missiles); tactics; and survivability. In addition, the T&E program will address the full spectrum of critical operational suitability issues: reliability, maintainability, availability, logistic supportability, training, and safety.

As noted below, as of this writing, the following significant issues with the overall T&E program remain:

- **ORD Deficiency.** The ORD is deficient in the following regard: (1) Although the ORD asserts that it will “support the evolutionary development of capabilities to meet the operational requirements,” it is ambiguous with regard to what initial functionality is required, and the schedule for delivering additional capabilities; (2) The currently proposed AIEWS/Aegis interface for OPEVAL significantly deprives the combat system of the improvements brought by AIEWS. It is noted that such a limited level of integration with the existing electronic warfare system, intended to be replaced by AIEWS, is described in the ORD as the major contributor to “shortcomings of existing system;” and (3) Going to OPEVAL with the proposed level of integration will require additional measures of effectiveness, with thresholds.
- **Realistic Simulation of Anti-Ship Cruise Missiles.** Increment 1 OT requires a platform, with appropriate radar cross section, that can carry anti-ship cruise missile active radar seekers or acceptable seeker simulators at threat-representative speeds and altitudes. The legacy platform, identified up front by the OT community as not meeting the requirement, uses a large, slow aircraft that cannot descend to threat-representative altitudes. The use of an existing target drone, integrated with an anti-ship cruise missile active radar seeker, appears to be an acceptable solution, but now adequate numbers of these drones will have to be funded for OT. For Increment 2, threat ASCMs or acceptable surrogates will be required.
- **Realistic Background Emitter Density.** As of this writing, the test range for the OT&E of AIEWS Increment 1 has not been identified. Whichever sea range is selected, the RF emitter resources for that range will have to be funded to ensure that a realistic background density of RF emitters exists for the testing.
- **Self Defense Test Ship (SDTS) for AIEWS Increment 2.** It is expected that anti-ship cruise missiles or very high fidelity surrogates will be required for OT&E. This will necessitate a follow-on SDTS in order to simulate threat-representative anti-ship cruise missile profiles and conduct safe testing.

## **AIM-9X SIDEWINDER AIR-TO-AIR MISSILE**

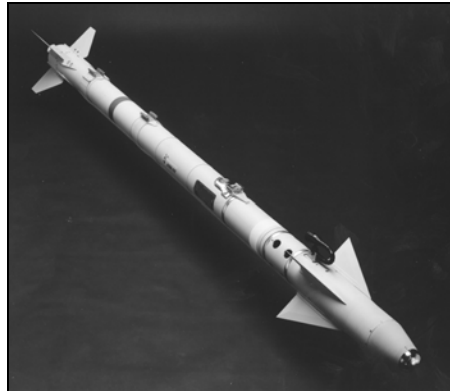

The AIM-9X Sidewinder Air-to-Air missile program is a follow-on modification to the existing AIM-9M short-range missile, for both USAF and Navy/Marine Corps fighter aircraft. AIM-9X is a highly maneuverable, launch and leave missile that uses passive infrared guidance to engage multiple types of targets. It will provide day/night capability with improved countermeasures resistance and High Off-Boresight (HOB) improvements relative to the AIM-9M. AIM-9X is designed to work with any on-board aircraft cueing source, including the Joint Helmet-Mounted Cueing System, which is being developed in a parallel program to enhance HOB capability.

The AIM-9X missile retains the warhead, fuze, and rocket motor of the established Sidewinder missile family. A new imaging infrared focal plane array seeker, thrust-vector tail-control actuation system, and state-of-the-art signal processor/auto pilot provide the missile with significant performance improvements. The F-15C/D and F/A-18C/D will be the initial platforms for AIM-9X integration and testing. The missile will eventually be integrated with the F-16, F/A-18E/F, F-15E, and F-22.

### **BACKGROUND INFORMATION**

AIM-9X is a joint Navy/Air Force program, with the Navy the Executive Service. Development was initiated in response to foreign missiles that clearly exceed AIM-9M capabilities. DEM/VAL began in 1994. AIM-9X is an Acquisition Reform program in which the contractor bears total system performance responsibility for a system that meets performance specifications derived from the Operational Requirements Document (ORD). The contractor is developing AIM-9X through an Integrated Product Team (IPT) management approach including Service and OSD membership. EMD began in January 1997, and is planned for completion in approximately six years. A full-rate production decision is scheduled for 3QFY03.

Modeling and simulation (M&S) is key to the development and evaluation of AIM-9X. Due to this missile's expanded capabilities and the high cost of test launches, a family of simulations will be used to assess missile performance across a wide spectrum of engagements encompassing various threats, backgrounds, and countermeasures. Live missiles are being used to validate these simulations. Since the same simulations will be used for OT and DT, DOT&E and the OTAs have been involved in the intensive M&S planning, from an independent Draper Lab assessment of the M&S strategy, through the decision to contract with the Joint Accreditation Support Activity to assist in simulation validation, verification, and accreditation (VV&A) efforts. DT VV&A plans from the Program Office were

developed with DOT&E participation and approval. Joint DT/OT technical review and accreditation panels continue to review M&S activities to support accreditation for LRIP, OT readiness, and Milestone III decisions.

The LFT&E program began with three warhead characterization (static) tests (same warhead as AIM-9M), to determine the affect of the added wiring harness and cover on warhead performance. Testing was conducted March-April 2000. LFT&E expanded when a primary threat target became available. In 1999, static testing of the warhead against this target demonstrated the lethality of the warhead for several expected endgame geometries. Results supported model improvements and will support validation of the Joint Service Endgame Model, which will be used in determination of AIM-9X Probability of Kill (Pk).

### **TEST & EVALUATION ACTIVITY**

AIM-9X test and evaluation activity has continued with additional captive carry development and demonstration tasks, and missile test launches from F-15s and F/A-18C/Ds. Six Separation and Control Test Vehicle (SCTV) launches were conducted to demonstrate missile aerodynamic performance in stressing scenarios. All launches were successful.

DT Phase IIB/C culminated with four successful Production Representative Model (PRM) missile shots against QF-4 drone target aircraft. The warheads of these PRMs were replaced with telemetry packages. DT IIB/C was followed by the DT-IID Technical Evaluation phase. This phase continued PRM tests to mature missile software, continue validation of simulation models, and prepare for OPEVAL in February 2002. All five PRMs in this phase successfully intercepted targets that were either maneuvering or dispensing infrared countermeasures in an adverse background.

### **TEST & EVALUATION ASSESSMENT**

The program has invested heavily in M&S to support development and testing, including simulation of potential threats, backgrounds, and countermeasures. Development of the simulation suite is progressing and validation continues to be done with both SCTV missile firings and PRM guided missile firings. The PRM configuration continues maturation of tracker software as planned to meet ORD Pk thresholds against the threat target employing countermeasures in clutter backgrounds. M&S will be used to assess ORD Pk against the threat targets. Simulation initiatives have allowed the number of guided test missiles to be significantly reduced. The AIM-9X program is conducting up to 22 developmental test and 22 OT&E guided missile launches, compared to AMRAAM's 103 development and 69 OT&E guided launches. Accordingly, if test results with these few missiles do not meet operational requirements or do not agree with simulation results, additional test missile firings will be required.

The AIM-9X program is strong. It demonstrates the benefits of a cooperative IPT approach by involving the prime contractor, program management, Air Force and Navy test organizations, and OSD in developing a practical and credible simulation strategy supporting missile development and OT&E.



## **AIRBORNE MINE COUNTERMEASURES RAPID AIRBORNE MINE CLEARANCE SYSTEM (RAMICS) AIRBORNE MINE NEUTRALIZATION SYSTEM (AMNS)**

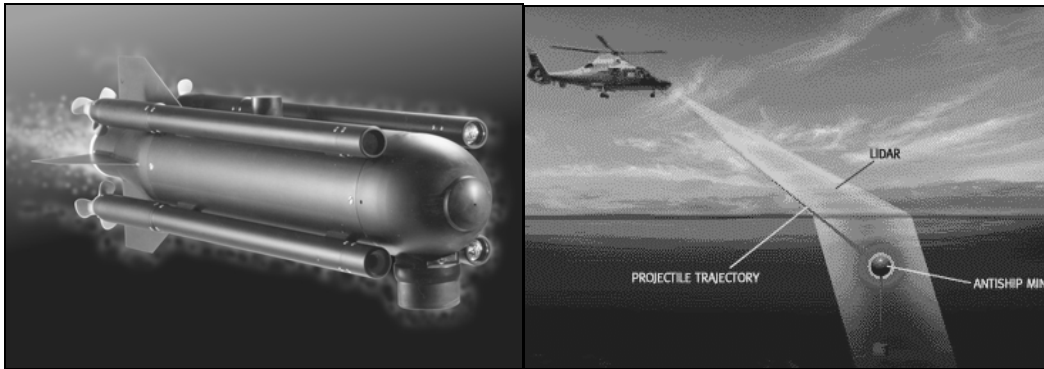

The Rapid Airborne Mine Clearance System (RAMICS) and the Airborne Mine Neutralization System (AMNS) are two of five modular Airborne Mine Countermeasures systems that will be integrated into the MH-60S helicopter to provide Carrier Battle Groups and Amphibious Ready Groups an organic mine countermeasures capability. These systems will reduce the time required to locate and neutralize mines and thus contribute to dominant maneuver in the littoral battle space and full dimensional protection from enemy mines.

RAMICS will be the first U.S. Navy weapon system to use the supercavitation phenomenon, which surrounds underwater objects traveling at high speed in a gas bubble that greatly reduces drag and allows them to maintain high velocity. RAMICS will use a laser imaging detecting and ranging (LIDAR) system to reacquire floating and near-surface moored mines detected previously by other systems and direct gunfire to neutralize or disable the mines from a safe distance. Once the target is reacquired, a fire control subsystem will automatically track the target and aim the LIDAR and the gun. The RAMICS munition is a flat-nosed 30mm armor-piercing, supercavitating projectile designed to be directionally stable in both air and water. The projectile will be fired in bursts from a MK44 Bushmaster II gun, which is also planned for installation in the AAV and LPD 17.

AMNS will be integrated into both MH-53E and MH-60S helicopters. Derived from a system built for German Navy mine countermeasures ships, AMNS will provide the capability to relocate, identify, and neutralize bottom and moored mines directly from the mine countermeasures helicopter. Target location information obtained from other sources will be entered into AMNS prior to take-off or while the aircraft is flying to the area of operations. The aircraft will then hover at a safe distance from the target and lower an expendable, self-propelled neutralizer device into the water. Once released, the neutralizer travels to the target position to commence a search for the target. It relays depth, position, and sensor (sonar and video) information to the operator in the helicopter via a fiber-optic cable. The cable is also used to send control and guidance commands to the neutralizer. Once the target is relocated and identified as a mine, the expendable neutralizer is positioned so that its shaped-charge will detonate into the vulnerable area of the mine. A successful mine neutralization attempt will render the mine inoperable either by rupturing its case or preferably by sympathetic detonation of the mine charge. A reusable training version of the neutralizer is also being procured with the system. The MH-53E will carry multiple neutralizers.

## **BACKGROUND INFORMATION**

RAMICS began as an Advanced Technology Demonstration (ATD) in FY98 and culminated in a full-scale demonstration of mine neutralization from a Cobra helicopter in the underwater explosion pond at Aberdeen Proving Ground, MD. Testing was also performed at the Naval Air Warfare Center, China Lake, CA, where 20mm supercavitating projectiles were fired from a platform-mounted Cobra gunship into surrogate mine targets located in a large water tank. Applicability of the ATD testing to the current RAMICS concept is limited because it used 20mm projectiles instead of the 30mm version subsequently selected. Additionally, the surrogate mine targets used for ATD testing were not fully representative of RAMICS threats.

An AMNS technology demonstration was conducted in 1997, and open-water testing was completed in 2000. Shipboard suitability testing was conducted onboard USS *Inchon* (MSC 12), USS *Peleliu* (LHA 5), USS *Boxer* (LHD 4), and USS *Ogden* (LPD 5) in 2000. Aquarium tests, performed in a water tank at Fort AP Hill, were completed to determine the lethality of the shaped-charge warhead against threat-representative plate targets.

## **TEST & EVALUATION ACTIVITY**

AMNS DT-IIA (MH-53E integration testing) was conducted during March and April 2001, at the Naval Surface Warfare Center, Dahlgren Division, Coastal Systems Station, Panama City, FL. DT-IIB (TECHEVAL) commenced on May 3, 2001, also at the Coastal System Station. The first phase of DT-IIB was conducted from the research vessel *Athena* using MH-53E AMNS subsystems with training neutralizers. This testing, a portion of which was observed by DOT&E, was conducted in shallow and deep operating areas containing inert U.S. and foreign mine shapes. Testing then moved to the MH-53E helicopter to evaluate helicopter integration, system installation and operating procedures, weapons loading/unloading procedures, in-flight safety, and system performance when operated from the helicopter. This testing was also conducted using training neutralizers in shallow and deep fields containing inert mine shapes and other mine-like objects.

DOT&E observed RAMICS Phase I Lethality Tests conducted in August and October 2001 at the West Freugh Test Facility in southwest Scotland. In these tests, production-representative RAMICS projectiles were fired at six U.K. MK17 mines from a platform-mounted MK 44 Bushmaster gun. These tests were well-instrumented and provided projectile velocity and lethality data for further analysis. Three RAMICS safe standoff tests were conducted during FY01 at the Energetic Materials Research and Testing Center, Socorro, NM, using mine targets that are considered the worst case for fragments. These tests helped to collect fragment mass and velocity data, which will be used in a Naval Air Systems Command model to determine the safe standoff distances for the MH-60S helicopter to avoid being hit by fragments from exploding mines.

## **TEST & EVALUATION ASSESSMENT**

The OT and LFT&E strategies for RAMICS and AMNS have not yet been approved by DOT&E. Although details remain to be worked out, the test programs outlined in the draft AMNS TEMP should support an adequate assessment of AMNS effectiveness and suitability, including neutralizer lethality and potential vulnerabilities to aircraft and ships carrying AMNS. AMNS demonstrated the capability to launch training neutralizers, relocate mine targets, and correctly position the neutralizer for mine

neutralization during testing observed by DOT&E. DT of expendable neutralizer performance against inert and live mines has been delayed pending identification of a suitable site for live-on-live testing and correction of a communication problem between the neutralizer and helicopter-based system components.

Completed RAMICS T&E activities have demonstrated that the system concept is viable and have generated significant data on RAMICS lethality and host aircraft vulnerabilities, providing a good foundation for LFT&E. The results of the RAMICS Safe Standoff (SSO) Tests conducted in Socorro, NM, indicated that fragments from detonating a worst-case surface threat mine were more lethal than expected, and may require a greater SSO distance than originally expected for the helicopter firing the RAMICS projectile.

Phase I Lethality Tests conducted at the West Freugh Test Facility in Scotland showed that the RAMICS projectile is capable of penetrating the casing of a large near-surface mine, causing it to sink. Although the water characteristics (salinity and depth) and the target mine depths were considered mission representative, the projectile travel distance was significantly limited by the range facilities, and the sensor and fire control components of the system were not tested.

This Page Is Intentionally Left Blank

## **AMPHIBIOUS ASSAULT SHIP (REPLACEMENT) (LHA (R))**



The Navy's next class of amphibious assault ships, now designated LHA(R), will replace the amphibious lift capability of retiring *Tarawa*-Class LHAs. In addition, the LHA(R)s will launch pre-loaded assault craft (amphibious vehicles and landing craft), tiltrotor aircraft, helicopters, Unmanned Aerial Vehicles and Short Take-Off Vertical-Landing fixed-wing aircraft to support both the rapid buildup of combat power ashore and the rapid re-embarkation of the landing force during amphibious operations. As the primary aviation platform within the amphibious task force, the LHA(R) must conduct simultaneous day and night, well-deck and flight-deck operations. Finally, the ship is expected to have C4I capabilities sufficient to support Operational Maneuver from the Sea/Ship-to-Objective Maneuver operations for Marine Expeditionary Unit/Brigade-size amphibious task forces and other assigned missions in a joint environment.

### **BACKGROUND INFORMATION**

The LHA(R) Mission Need Statement was approved in March 2001. Milestone A occurred in July 2001. Alternative ship concepts to be evaluated in the Analysis of Alternatives will include a repeat Amphibious Helicopter-Dock Ship (LHD) Class Ship, modified LHD-8 variants, and several larger, more capable designs.

### **TEST & EVALUATION ACTIVITY**

DoD 5000.2-R requires that the Navy submit an evaluation strategy within 180 days after Milestone A. Toward that end, the LHA(R) program office has developed a planning schedule that culminates with the submission of the strategy to OSD for approval by January 2002. Because there is no prescribed format for an evaluation strategy, DOT&E has met with representatives from the LHA(R) program office and Navy staffs to identify in detail those LFT&E and OT issues that should be addressed.

## **TEST & EVALUATION ASSESSMENT**

The Navy's proposed schedule for writing and staffing the evaluation strategy for the LHA(R) is satisfactory. Both the COMOPTEVFOR and Director, MCOTEA have been asked to participate and contribute directly to the development of the strategy.

The effectiveness of the LFT&E program for the LHA(R) will be particularly sensitive to early implementation of many of the LFT&E program elements, since the results should impact the ship's design. In particular, three of these elements are surrogate testing, carried-weapons analyses and testing, and modeling and simulation improvements. The decisions on how these three LFT&E elements will be applied should be completed by the FY03 Program Initiation Decision Review.

## AMPHIBIOUS TRANSPORT DOCK SHIP (LPD 17)

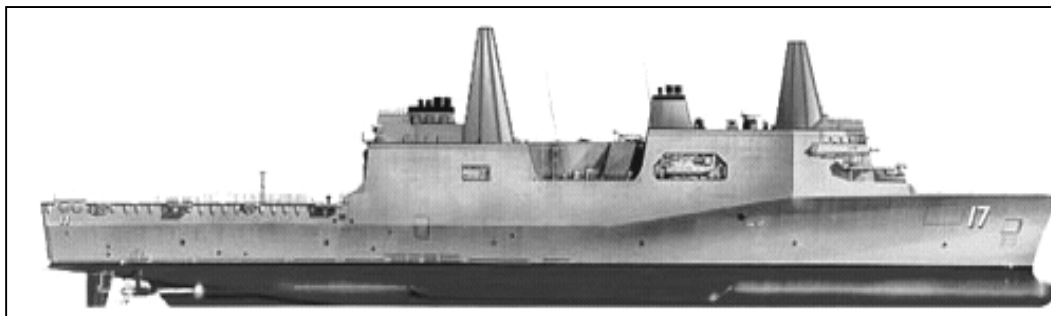

USS *San Antonio* (LPD 17) will be a diesel-powered amphibious assault ship that will transport and deploy the combat and support elements of Marine Expeditionary Units/Brigades as a key component of amphibious task forces. LPD 17 will be capable of debarking forces by surface assault craft, including current and advanced amphibious assault vehicles (AAAV), air cushioned landing craft, conventional landing craft, as well as helicopters and MV-22s, contributing to dominant maneuver and focused logistics. A large flight deck will enable the aerial transport of troops and equipment, and a floodable well deck will permit operation of air-cushioned landing craft, conventional landing craft, and amphibious assault vehicles. The LPD 17 Class is required to conduct simultaneous day and night, well deck and flight deck operations and is expected have C4I capabilities sufficient to support operational maneuver from the Sea/Ship to objective maneuver operations.

Self-defense capabilities of the LPD 17 will include a cooperative engagement capability with other task force vessels, plus the Mk-2 variant of the ship self-defense system (SSDS), rolling airframe missile (RAM), and the Nulka decoy system to provide own-ship defense against anti-ship cruise missiles (ASCMs). Defense against surface threats will be provided by two Mk 46 30-mm gun systems that are currently being developed separately by the Marine Corps for use on the AAAV. Installed C4I systems will interoperate through a modern ship wide area network (SWAN).

### **BACKGROUND INFORMATION**

LPD 17 completed a Milestone II review in June 1996, and OSD approved the current TEMP in February 2000. The TEMP is currently being updated because of program baseline breaches; this revision -- with updates to DT, OT, LFT&E plans and strategies -- is expected in 2QFY02.

OPTEVFOR conducted Early Operational Assessments (EOAs) OT-IA and OT-IB in FY95 and FY96. Design deficiencies identified during these EOAs included incompatibility with night vision devices (NVDs), self-defense systems performance, joint planning capability, design and equipment shortfalls in electronic warfare and intelligence facilities, and chemical, biological, and radiation (CBR) defense capabilities.

The current LFT&E strategy was approved by OSD in the February 2000 TEMP Update. A waiver from full-up, system-level testing was granted and an alternative LFT&E plan was approved by OSD in June 1996. The overall ship design and construction schedule has been delayed 24 months due to the shipbuilder's lack of readiness to begin construction. This delay has given the Navy more time for

development and improvement of LFT&E modeling and simulation tools and will permit missile/mine/torpedo encounter susceptibility studies to provide more credible hit distributions.

## **TEST & EVALUATION ACTIVITY**

An OT-IIA was conducted from April 1999 through August 2000 by fleet experts in areas associated with amphibious warfare, organized under the leadership of COMOPTEVFOR and the Director, MCOTEA. The results were reported in April 2001 to DOT&E. Although the evaluations consisted for the most part of reviewing ship specifications and design drawings, the assessment team also examined results from modeling and simulation conducted as part of the ship design process.

## **TEST & EVALUATION ASSESSMENT**

Overall, the LPD 17 class was designed to incorporate considerable amphibious lift as well as advances in shipboard application of information technology, radar cross-section reduction, and improved habitability for the crew and embarked Marines. However, the OT-IIA provided a number of key insights, which were, in some cases, design deficiencies identified as early as 1995 and re-discovered in subsequent EOAs. They still exist and there does not appear to be any resolution of them. These major shortcomings must be corrected to ensure that the LPD 17 is operationally effective and operationally suitable, discussed below:

- The only hard-kill system is the RAM. In conjunction with soft-kill systems (Giant, Nulka, and chaff), RAM must achieve the threshold requirement for ASCM defense. Defense against aircraft is vulnerability, because LPD 17, the first ship of the class to be delivered, is not expected to have any capability against these threats. In addition, there are concerns about the ship's capability to detect/track/engage some classes of ASCMs and its susceptibility to torpedoes and mines.
- Shortcomings exist in the ship's C4I systems, particularly as they relate to ship-to-tactical-shore data exchange. Specifically: (1) the ship's radio communication system does not support internet protocol data connectivity to shipboard landing force C4I systems through the ship's automatic data network system to the SWAN; (2) although the ship should provide a minimal supporting arms and tactical air coordination to support split-amphibious ready group operations, essential C4I systems are not part of the ship's baseline; (3) a key joint planning system necessary for originating and validating movement requests among Joint Task Force Service components is not provided; (4) servers for two landing force logistics automated information systems are not in the baseline; the Joint Deployable Information Support System is not included in the baseline, thereby compromising the ship's capability to support joint intelligence collection for the ship and embarked landing force elements; (5) "real-time" tracks provided by SSDS Mk 2 are not automatically fused with "near real-time" friendly unit positions and control measures provided by the ship's Amphibious Assault Direction System; and (6) there are not enough Enhanced Position Location Reporting System units to support the anticipated volume of position location information and other data needed for situational awareness.
- The LPD 17 will not fully support simultaneous night and day, flight-deck and well-deck operations because of a lack of NVD-compatible lighting and displays. This will limit the



capability to conduct simultaneous flight-deck operations and well-deck operations when NVDs are required because of safety concerns.

- The LPD 17 will be fitted with a collective protection system to protect berthing areas, messing and food preparation/storage areas, command and control spaces, and medical spaces, and a water wash-down system to reduce the effect of a CBR attack. However, the ship must interoperate with landing craft and vertical takeoff and landing aircraft, which might be exposed to agents during their operations and there are no provisions for decontaminating landing craft, aircraft, and landing force equipment in the well deck or on the flight deck. Chemical agent detectors/alarms are not integrated into the ship's information system. Furthermore, a tenet of chemical and biological warfare defense is to avoid contamination, thus requiring standoff detectors, however, none are required by the ORD.
- The LPD 17 has been designed to carry a substantial amount of cargo; however, there are no backup systems for the elevators that service two of the ship's three cargo and ammunition magazines.
- Other deficiencies discovered include the lack of the Level 5 Tactical Control System needed to launch, control, recover, and receive downlink information from unmanned aerial vehicles. There is insufficient support for MV-22 organizational-level maintenance.
- The Navy plans to conduct a Shock Trial on the lead ship in FY06, but DOT&E has concerns about the funding for this trial. In spite of Navy requests to cover increased costs estimates, the Shock Trial remains only partially funded. LFT&E modeling and simulation tools are under development, but thus far have limited capabilities and a weak test basis for validation.

LPD 17 will be equipped with sensors and systems for air surveillance and air warfare. The combat system's effectiveness depends strongly on the successful integration of these disparate sensor, weapon, and control element programs, and this task presents considerable risk. The most significant future T&E challenge for the LPD 17 will be credibly assessing the ship's self-defense capability against ASCMs. Safe and sufficiently realistic testing requires use of an unmanned Self-Defense Test Ship (SDTS) capable of being remotely operated during operationally realistic ship air defense scenarios. Results of these tests will also be used to validate modeling and simulation tools to estimate the Probability of Raid Annihilation for various scenarios. Consequently, the Navy should resource the installation of the LPD 17 combat system aboard an SDTS as well as the threat representative targets that are required.

This Page Is Intentionally Left Blank

## **ARLEIGH BURKE (DDG 51) CLASS GUIDED MISSILE DESTROYER WITH THE AEGIS WEAPON SYSTEM, AN/SPY-1D/D(V) RADAR AND AN/SQQ-89(V) INTEGRATED SURFACE SHIP ANTI-SUBMARINE WARFARE COMBAT SYSTEM**



The *Arleigh Burke* (DDG 51) class of multi-mission, battle force capable guided missile destroyers provides precision engagement of targets ashore, full-dimensional protection of joint and allied forces, and dominant maneuver in the open oceans and littorals around the globe. DDG 51s are being constructed in flights to incorporate technological advancements during construction. Flight I (DDG 51-71) and Flight II (DDG 72-78) configurations are described in prior year reports. This report focuses on early Flight IIA ships with the AEGIS Baseline 6 Phase I computer program (DDG 79-84), which are now entering the Fleet. The AEGIS Weapon System (AWS), which includes the SPY-1D radar and SM-2 surface-to-air missiles, provides the ship's area air defense capability. The Phalanx close-in weapon system, SM-2 missiles, and 5-inch gun provide self-defense against anti-ship missiles. For anti-submarine warfare (ASW), DDG 51 uses the AN/SQQ-89 surface ASW combat system, two embarked Light Airborne Multi-Purpose System (LAMPS) MK III helicopters, torpedoes, and vertically launched ASW standoff weapons. Surface warfare weapons include the 5-inch gun and LAMPS MK III helicopters armed with Penguin or Hellfire missiles. TOMAHAWK missiles and the 5-inch gun are used to engage shore targets. Four LM 2500 gas turbine engines provide power for a maximum speed in excess of 30 knots. Data Link connectivity to other Navy, Joint, and Allied forces is provided via Links 4A, 11, and 16.

The SPY-1D radar system is a multi-function, phased-array, three-dimensional (range, altitude, and azimuth) radar that conducts search, automatic detection, and tracking of air and surface targets. The SPY-1D also provides mid-course guidance for the SM-2 missile. AN/SPY-1D(V), a new variant under development for installation in later Flight IIA ships, is expected to improve performance against targets in clutter and have greater ability to counter deceptive electronic attack measures.

The AN/SQQ-89(V) series of ASW combat systems links acoustic sensors and weapon control systems with advanced data processing and information displays. The AN/SQQ-89(V)6, which is installed in Flight I and Flight II DDG 51 class ships and other combatants, is the baseline system for ships with a towed array. It integrates the AN/SQS-53 series hull mounted sonar, the AN/SQR-19(V) Tactical Towed Array Sonar, and the AN/SQQ-28(V) LAMPS MK III shipboard electronics with the ASW Control System MK 116 series. For Flight IIA DDG 51 class ships, the AN/SQQ-89(V)10 removes the AN/SQR-19 towed array, while (V)14 reorganizes the functional segments, and (V)15 introduces a

COTS-based system. Eventually, A(V)15 will replace the AN/SQR-19 on Flight I and II ships with the new Multi-Function Towed Array.

## **BACKGROUND INFORMATION**

DDG 51 has an extensive OT&E history. DOT&E's FY91 report contains a complete summary of OT conducted prior to commissioning of the lead ship. The results of the first at-sea testing of the Flight I ship, conducted in DDG 51, were detailed in DOT&E's FY92 report. Subsequent FOT&E, which reexamined the ship's ASW effectiveness and the Gun Weapon System was discussed in DOT&E's FY94 and FY96 reports. The results of FOT&E of the Flight II variant were reported in DOT&E's FY00 report. Overall, Flight I and II DDG 51 class ships and the AN/SPY-1D radar are assessed to be operationally effective and suitable. The Flight I LFT&E Program, which included a 1994 Shock Trial and a 1995 Total Ship Survivability Trial, is complete. Flight II ship design survivability will be assessed as part of the Flight IIA LFT&E Program.

DOT&E assessed the AN/SQQ-89(V)6 ASW combat system installed in the DDG 51 class ship to be operationally effective and operationally suitable. The SQQ-89(V)6 Torpedo Alertment Upgrade was assessed to be neither operationally effective nor operationally suitable. Previous AN/SQQ-89(V) testing, including recent FOT&E of the Torpedo Alertment Upgrade, is described fully in the FY00 Annual Report.

## **TEST & EVALUATION ACTIVITY**

DDG 51 OT activity in FY01 was dedicated to preparation for FOT&E (OT-IIIIE) of the Flight IIA DDG 51. Revision 9 of the DDG 51 TEMP was approved by DOT&E in October 2001 to support this testing. Conducted in October 2001 aboard USS *Roosevelt* (DDG 80), OT-IIIIE evaluated the performance of a Flight IIA ship with the AEGIS Baseline 6.1.3 configuration. Testing was conducted during the USS *John F. Kennedy* (CV 67) Battle Group Composite Training Unit Exercise at the Atlantic Fleet Weapons Training Facility. DOT&E and COMOPTEVFOR are analyzing the data collected during OT-IIIIE with a final report due in January 2002. Flight IIA FOT&E will continue during FY02 with test events in USS *Winston S. Churchill* (DDG 81), USS *Lassen* (DDG 82), and USS *Bulkeley* (DDG 84). FOT&E will include assessment of the AEGIS Baseline 6.1.5 configuration and DDG 51's capability to defend against multiple fast patrol boat attacks using all available weapons. FOT&E will also be conducted in USS *Cole* (DDG 67) to evaluate the performance of the AEGIS Baseline 5.3.8 computer program, which is being installed in Flight I and Flight II ships. A second phase of land-based AN/SPY-1D(V) DT/OT will be conducted in FY03.

During FY01, DOT&E participated in the revision process for the AN/SQQ-89 ORD and TEMP. DOT&E's objective is to ensure that testing of the AN/SQQ-89(V)14 and future variants and DDG 51 Flight IIA is coordinated and adequately addresses critical ASW issues. In particular, since the Torpedo Alertment Upgrade was determined to be not operationally effective or suitable in its FY00 FOT&E, DOT&E will continue to monitor the torpedo detection performance of future variants closely and will continue to advocate realistic OT in that area.

Two key LFT&E events were conducted during FY01. The Flight IIA Total Ship Survivability Trial was conducted in January 2001 aboard USS *Oscar Austin* (DDG 79). A Shock Trial was conducted during May and June 2001 aboard DDG 81. The Navy is currently evaluating the results of both of these tests. The LFT&E effort is highly dependent on modeling and simulation. During FY01, the Navy

accredited several models for the DDG 51 LFT&E Program, including the Naval Research Laboratory's Radar Target Signature Model, CRUISE\_Missiles Simulation, ShipIR Ship Infrared Signature Model, IR\_CRUISE\_Missiles Simulation, and the Johns Hopkins University Applied Physics Laboratory's AEGIS Weapon System Models Network. Accreditation of several other models is in progress. Navy and DOT&E personnel have also been involved in analysis of damage to the USS *Cole*.

## **TEST & EVALUATION ASSESSMENT**

Based on testing up through FY00, Flight I and II DDG 51 class ships and the AN/SPY-1D radar are assessed to be operationally effective and suitable. An assessment of Flight IIA with the AEGIS Baseline 6.1 configuration will be included in the FY02 report.

The DDG 51 Program Office does not have the resources to support robust dedicated FOT&E events, making it necessary for COMOPTEVFOR to seek out opportunities to combine OT with other evolutions, such as DT and fleet training exercises. DDG 51 FOT&E was conducted during fleet training exercises in FY00 and early FY02. The Report of the Defense Science Board Task Force on Test and Evaluation Capabilities noted that combining OT with training has both benefits and drawbacks. Planning for the FY02 test event once again highlighted the difficulty of informally coordinating the needs of trainers and testers. In particular, operational testers were given little advance information about the scenarios for the upcoming events and had no input to the planning process or control over the flow of events. This made it difficult to assess the adequacy of the test to achieve the stated objectives. The Navy's training and test organizations need to formalize procedures for combined events in order to afford operational testers early access to the planning process and better coordinate T&E objectives with training objectives.

This Page Is Intentionally Left Blank

## COOPERATIVE ENGAGEMENT CAPABILITY (CEC)

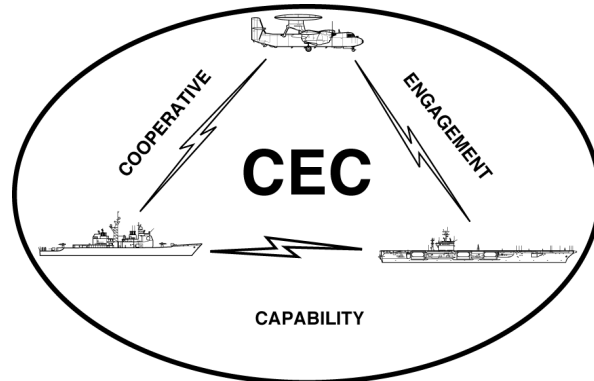

The Cooperative Engagement Capability (CEC) is a system of hardware and software that allows ships to share radar data on air targets. Radar data from individual ships of a Battle Group is transmitted to other ships in the group via a line-of-sight, data distribution system (DDS). Each ship uses identical data processing algorithms resident in its cooperative engagement processor (CEP), resulting in essentially the same display of track information on aircraft and missiles in each ship. An individual ship can launch an anti-air missile at a threat aircraft or anti-ship cruise missile (ASCM) within its engagement envelope, based on radar data relayed to it by another ship. Program plans include the addition of E-2C aircraft equipped with CEP and DDS, to bring airborne radar coverage plus extended relay capability to CEC. CEP-equipped units, connected via the DDS network, are known as Cooperating Units (CUs).

### **BACKGROUND INFORMATION**

An at-sea demonstration of CEC was conducted during FY90. An early operational assessment was conducted in FY94, based on results of at-sea developmental testing, including missile firings at the Atlantic Fleet Weapons Training Facility in Puerto Rico. Although there were significant operational realism limitations, CEC was determined to be potentially operationally effective and potentially operationally suitable. Approval to begin EMD (Milestone II) was granted in May 1995. An additional early operational assessment (OT-1A) of the airborne component of the CEC network was conducted in September 1995. In accordance with congressional guidance, the Navy certified IOC for CEC (engineering development model equipment upgraded to AN/USG-1) in late FY96.

OT&E to support the initial LRIP decision of AN/USG-2 equipment was conducted in August 1997. Although CEC was assessed as being potentially operationally effective and potentially operationally suitable, significant problems were observed in Battle Group interoperability and in software reliability. Interoperability problems experienced in early 1998 at-sea testing with the latest Aegis Weapon System software involved CEC, as well as the Aegis Weapon System, ACDS Block 1, and the command and control processor for the tactical data links. This resulted in freezing the CEC software configuration (Baseline 2) and decelerating CEC development so that associated system software (Aegis Weapon System (AWS) Baseline 6.1 and Advanced Combat Direction System (ACDS) Block 1) could catch up.

The replanned program, challenged by the requirement to synchronize testing with fleet deployment schedules, included four at-sea test periods in 2000, followed by TECHEVAL and OPEVAL in 2001. The full production decision is expected during 1QFY02. CEC was designated as an ACAT ID program in FY99.

## **TEST & EVALUATION ACTIVITY**

Analysis of results from DT-IIF/OT-IIA3, conducted in late September 2000 in the Virginia Capes (VACAPES) operating area, continued into October and November 2000. This was the first time that such a large number of CUs had been assembled for testing, and problems were discovered with network operations. From the analysis, software fixes were developed to mitigate the effects of the problems for the December 2000 testing.

As a precursor to the Technical Evaluation (TECHEVAL), a phase of DT was conducted in December 2000, both at the Atlantic Fleet Weapons Training Facility (AFWTF) in Puerto Rico and in the VACAPES operating area. Participants in the Puerto Rico phase included four Aegis cruisers (two with AWS Baseline 5.C and two with AWS Baseline 6.1), one CEC-equipped aircraft equipped with CEC, and a CEC node at Saint Thomas, VI. In the Virginia Capes area, participants were the four cruisers, the two land-based test sites (LBTS) at Wallops Island, VA and at Dam Neck, VA, two CEC-equipped aircraft, and two ACDS Block 1 ships, USS *John F. Kennedy* and USS *Wasp*. Extensive tracking runs were conducted against aircraft and target drones. EA was conducted against ship radars. Standard Missiles and Sea Sparrows were fired at target drones. Two non-CEC Aegis destroyers participated in the exercise. This testing was observed by DOT&E staff.

TECHEVAL was conducted during February and March 2001, again at AFWTF and in the VACAPES area. Testing followed the same pattern as for the precursor DT in December 2000 except that the ACDS Block 1 ships also participated during the phase at AFWTF.

OPEVAL was conducted in late April 2001 at AFWTF and in early May 2001 in the VACAPES area. As during the preceding DT, CEC-capable participants involved four Aegis cruisers (two with AWS Baseline 5.C and two with Baseline 6.1), two ACDS Block 1 ships (the aircraft carrier USS *John F. Kennedy* and the amphibious warfare ship USS *Wasp*), two aircraft (an E-2C and a P-3 configured to emulate an E-2C) and, in the VACAPES area only, two land-based test sites in Virginia (Surface Combat Systems Center at Wallops Island, configured as Aegis Baseline 6.1, and the LBTS at Dam Neck, configured as ACDS Block 1 with SPS-48E radar). For both phases, two non-CEC Aegis destroyers were participants. At both locations, a land-based DDS relay station provided another node in the CEC network.

OPEVAL included 23 days underway for the *Kennedy* Battle Group and the two Aegis Baseline 5.C cruisers. Thirteen days were on the firing ranges at AFWTF and VACAPES. Both actual and simulated missile firings were conducted against 42 targets that simulated high-altitude as well as sea-skimming enemy ASCMs. In some cases, actual ASCMs were used as targets.

Testing was conducted in accordance with a DOT&E-approved TEMP and test plan. The Director observed part of the VACAPES phase and his staff observed most of the testing at both locations.



## **TEST & EVALUATION ASSESSMENT**

Based on results of the OPEVAL, the surface CEC AN/USG-2(V) equipment with CEC Baseline 2.0 software is operationally effective and operationally suitable. Situational awareness was improved and CEC ships were able to track and engage targets at greater ranges than without CEC. The extension of range at which detection and tracking occurred improved survivability of CEC ships by increasing the opportunity for additional missile salvos. Notwithstanding these conclusions, results also indicate that the full benefit of CEC has not been realized by virtue of the immature Aegis Weapon System Baseline 6.1 and the limited Aegis Display System in the Aegis cruisers, as well as the defective ACDS Block 1 system installed in USS *Kennedy* and USS *Wasp*. (ACDS Block 1 was determined to be neither operationally effective nor operationally suitable during its February 1998 OPEVAL and during subsequent OT&E. Its successor system, the Ship Self Defense System Mark 2, is still in development.) The Battle Group Integration and Interoperability COI was resolved as unsatisfactory. The Joint Interoperability COI was partially resolved; further examination during FOT&E is required.

CEC exceeded its availability and reliability thresholds and, while it is considered maintainable, improvement in the built-in-test is needed. The Maintainability COI is partially resolved; correction of the noted deficiencies and retest during FOT&E are required. COIs of Logistic Supportability, Compatibility, Interoperability, Training, Human Factors, Safety, and Documentation were resolved as satisfactory, although training issues with the combat systems, vice CEC, degraded overall results.

## **LESSONS LEARNED**

The PEO implemented an analytical and management structure to examine test data from the major subsystems: AWS, ACDS Block 1, CEC, and the tactical data link command and control processor. Through collaborative analysis between the major subsystem teams, rapid feedback was provided to a senior system engineering council that made recommendations to the PEO regarding software modifications to enhance overall system performance.

This system of systems using different ship classes and aircraft was replete with interoperability challenges, as well as the potential for significant progress toward realization of a single integrated air picture for Battle Group units. The interoperability challenges were the major obstacles, and while the Navy addressed them impressively, as evidenced by their significant commitment of ships, aircraft, land-based test sites, and other resources during the multiple at-sea periods of testing, there is still work to be done.

This PEO's overall approach could establish a pattern for emulation by other acquisition managers challenged with the development and delivery of complex, highly interactive systems of systems that cut across PMs, PEOs, Systems Commands, and other organizational boundaries.

This Page Is Intentionally Left Blank

## CVN(X) FUTURE AIRCRAFT CARRIER

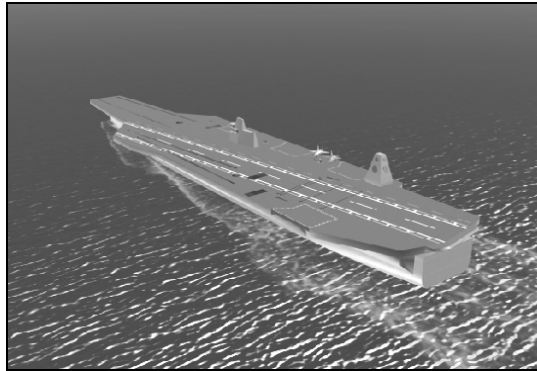

CVN(X) is a new class of nuclear-powered, large deck aircraft carrier. The first ship, CVNX1, is projected to be part of the fleet for at least 50 years – through 2063. In addition to the new F/A-18E/F, CVN(X) will also integrate two emerging aircraft systems: the Joint Strike Fighter (JSF) and Unmanned Combat Air Vehicle – Navy (UCAV-N). These three new aircraft systems, coupled with its new Integrated Warfare System (IWS) will provide future joint force commanders with enhanced strategic and operational capabilities.

CVNX1 will have a *Nimitz* class hull, an upgrade of the CVN-77 weapon system, new designs for its reactor and propulsion plants, and significant changes to its electrical power generating capacity. This additional electrical capacity will power a new Electro-Magnetic Launching and Recovery Systems (EMALS and EARS respectively). CVNX1 is planned to introduce the new EMALS and a legacy recovery system. CVNX2 will have both EMALS and EARS. The decision to start replacing steam driven catapults with EMALS in CVNX1 will be made in FY02.

### **BACKGROUND INFORMATION**

OSD approved the Navy's evolutionary approach to acquisition of a new aircraft carrier in a June 2000 Milestone I decision, following an Analysis of Alternatives (AOA) concerning potential approaches and designs. Part 1 of the AOA was completed in 1997 and focused on the carrier air wing (CVW) composition and selected an 80-plane air wing. Part 2 of the AOA was completed in 1998 and selected the *Nimitz* class hull for CVNX1 with evolutionary improvements in CVNX2 and follow-on ships. Part 3 of the AOA ended in January 2000 and considered six new designs and eight modified CVNX1 designs before settling on concept designs for CVNX2. A Milestone B (MS B) decision is scheduled for Summer/Fall 2002, with construction of CVNX1 to begin in 2006.

Using an evolutionary approach to acquisition, major elements of the CVN(X) IWS will be based on that for CVN-77, the last ship in the *Nimitz* class and also the transition ship to the CVN(X) class. CVN-77's IWS will include a new Multi-Function Radar (MFR), AN/SPY-1D search radar, Rolling Airframe Missile weapon system, and Evolved Sea Sparrow Missiles for self-defense against cruise missiles.

## **TEST & EVALUATION ACTIVITY**

DOT&E approved the CVN(X) TEMP that supported the Milestone I decision in June 2000. The program manager decided to accelerate the MS B decision several years to Summer/Fall 2002 to support advanced funding for the nuclear power plant while OPEVAL remained scheduled for 2013. This raised concerns at all levels regarding the maturity of the program to adequately support a MS B decision in 2002. DOT&E provided the program comments to help make the MS 1 TEMP adequate for a MS B decision. Comments centered on the lack of detail regarding funding, measures of effectiveness, and modeling.

COMOPTEVFOR (COTF) is currently conducting an Early Operational Assessment (EOA), with a report due in March 2002 to support a Summer/Fall 2002 Milestone B decision.

The IWS has not been completely specified, thereby delaying determination of the extent of OT&E. Through the program's T&E IPT, DOT&E and COTF are developing a test approach. A TEMP is being drafted, with final approval anticipated for February 2003.

DOT&E has yet to approve the CVN(X) LFT&E Management Plan, the document that describes the testing and analysis necessary to assess the vulnerability of CVN(X) class carriers, which also must be adequate to support the Summer/Fall 2002 MS B decision. The Navy began a vulnerability assessment of a CVNX1 early baseline configuration for MS B using a set of engineered shotlines. DOT&E is participating in the review of primary and secondary damage for these assessments, as well as in the development of the recoverability actions. DOT&E also witnessed several tests evaluating the performance of armor systems and protection technologies, and some weapon sensitivity testing.

## **TEST & EVALUATION ASSESSMENT**

The CVN(X) OT&E planning is off to a slower than expected start and there is concern that a meaningful EOA may not be completed before the Summer/Fall 2002 MS B decision. Even if the MS B decision is postponed and advanced funding for the propulsion plant is delayed, the program has sufficient time to make significant schedule and design adjustments.

Advancing the MS B decision several years created two parallel test tracks. The low risk track involves the propulsion plant. The high risk track involves the successful integration of at least seven highly complex warfare systems at various levels of technical maturity: F/A-18E/F, JSF, UCAV-N, CVN-77 IWS, EMALS, EARS, and the large electrical system necessary to support EMALS and EARS.

Since the June 2000 MS1 decision, the program office has taken aggressive steps to ensure that it has a T&E team capable of supporting this very complex and lengthy test program. This team is working with COTF to develop a test plan that adequately supports both high and low risk test tracks. This involves setting up a significant number of operational assessments and OT&E phases between MS B in 2002 and OPEVAL in 2013.

In the case of the CVN-77 IWS, definitive operational requirements are a must. For air defense, IWS OT&E will focus on self-defense against the primary threat, anti-ship cruise missiles. Vulnerability assessment of the CVN-77 IWS will provide technical insights into improving CVN(X) IWS.

## DD(X) LAND ATTACK DESTROYER



In November 2001 the Navy restructured the DD21 Program and redesignated it DD(X) to focus on technology development and maturation, including robust land-based and at-sea testing of transformational technologies that could be leveraged across multiple ship classes. The Navy plans to conduct a spiral design review to assess the merits of achieving various levels of capability in a family of multi-mission ships, including the Land Attack Destroyer DD(X), a future cruiser CG(X) and a Littoral Combat Ship (LCS). The destroyer class will be designed first and draw heavily on the research and design work already performed for the DD 21. The DD(X) will use a more gradual spiral development approach consisting of several flights of destroyers leading to the final desired capability rather than the more risky single step approach envisioned for DD 21.

As in DD 21, the DD(X) Flight I is envisioned to have electric drive and will feature an integrated power system. The integrated power system design will allow sharing of electrical power between propulsion motors and other uses. Another DD(X) Flight I feature is an Advanced Gun System (AGS), which will meet land attack and surface mission requirements. Each AGS will consist of a single-barrel 155mm gun supplied by an automated magazine that will carry a family of long-range land attack and surface projectiles. The DD(X) will also include advances in survivability and computing power that will allow a significant reduction in crew size. Additionally, as these features are examined and refined and new technology introduced, the hope is to reduce manning with each succeeding flight.

The DD(X) will provide independent forward presence/deterrence and operate as an integral part of Naval, Joint, and Combined maritime forces. Tailored for land attack, the DD(X) mission is to carry the war to the enemy through offensive operations. It will provide precision engagement and dominant maneuver by conducting operations that include firepower support for amphibious and other ground forces and the launch of precision strike weapons. DD(X) will also provide friendly forces full dimensional protection from enemy attack through the establishment and maintenance of surface and undersea superiority and local air defense. Signature reduction is to be incorporated into the DD(X) design, allowing it to operate in all threat environments. DD(X) is the replacement for retiring *Spruance* (DD 963) class destroyers and *Oliver Hazard Perry* (FFG 7) class frigates, which are reaching the end of useful service life.

## **BACKGROUND INFORMATION**

In November 2000, two competing industry teams delivered DD 21 system preliminary designs and Smart Product Models that included virtual prototypes of their proposed DD 21 systems. No downselect was made and the DD 21 program was put on indefinite hold in May 2001 pending the administration's plan to transform the services. The program was on hold until November 2001 when DD 21 was restructured into the DD(X) program. In spring 2002 the Navy plans to select one of the two teams to act as the design agent for DD(X). The lead ship will be acquired under a separate contract in FY05.

During 4QFY98, an LFT&E Weapon Effects Test was performed against ex-USS *Richmond K. Turner* (CG 20) by detonating an onboard explosive charge. A second Weapon Effects Test completed during 2QFY00 included the firing of a live, subsonic SLAM-ER missile against ex-USS *Dale* (CG 19) and the detonation of an onboard explosive charge. The objectives of these tests were to generate weapon effects data needed for the improvement and validation of damage models and to demonstrate real threat weapon damage on Navy ships to industry designers. The second test also examined ballistic damage from missile impact and weapons-induced fires. Data collected from these tests, performed for the DD 21 program, will be used to validate damage models, which will be used for the design and vulnerability assessment of DD(X). The post-test exhibition and documentation of the damage provided a valuable database for the survivability design of DD(X).

## **TEST & EVALUATION ACTIVITY**

Activity has been limited due to the program's delay and restructuring, but DOT&E has participated in Multi-Function Radar test planning meetings and Advanced Gun System program reviews. The Advanced Gun System core program continues to make progress in gun, projectile, and propellant development, which will be part of the DD(X) design. In August 2001, United Defense Limited Partnership successfully fired a slug projectile from the first of three Advanced Gun System test barrels. DOT&E has been monitoring initial planning efforts for a FY02 Weapon Effects Test that will examine damage mechanisms associated with supersonic threat weapons.

## **TEST & EVALUATION ASSESSMENT**

Because of the lengthy DD 21 program hold, DOT&E's assessment is unchanged from that detailed in last year's report. The DD 21 Program established a solid framework for T&E. The DD(X) program should use that work and begin a more focused T&E effort once DD(X) programmatics become clearer. The TEMP for the new program must provide a clear T&E roadmap and show that the T&E program will produce the data necessary to support an informed Milestone decision. DOT&E strongly recommends a high level of early OT and user community involvement in performing Early Operational Assessments (EOAs). These EOAs provide opportunities to identify and correct any significant shortcomings in the DD(X) design, which should reduce the requirement for costly changes during the construction process.

# DEFENSE INTEGRATED MILITARY HUMAN RESOURCES SYSTEM (DIMHRS)



The objective of the Defense Integrated Military Human Resources System (DIMHRS) is the automation and integration of personnel and pay entitlement business processes into a standard single point of entry system that will collect, pass, use, and report personnel and pay entitlement data. DIMHRS will provide a fully integrated military personnel and pay system for all components of the Military Services. It will replace 17 legacy systems including all currently operating Service-specific pay and personnel systems. It is being developed based upon commercial-off-the-shelf applications. Extensive reengineering of business practices that capture the best of both private and public sectors is expected.

The initial core system of DIMHRS will provide support to processes that are common to all Services. This core system shall collect, store, pass, process, and report personnel and pay data for all DoD Active Duty, Reserve, Guard, and retired personnel. DIMHRS will support the responsibilities and requirements of the individual Military Service Departments and, in time of war, the Coast Guard. Common software and data bases are the foundation of DIMHRS.

The Services will retain their structure management command and control functions to ensure personnel operational readiness. Personnel and pay organizations will use DIMHRS at all echelons of command to support personnel and pay functions. Managers and analysts in the OSD, the Joint Staff, and other federal agencies will also use DIMHRS data for planning and reporting purposes.

## **BACKGROUND INFORMATION**

DIMHRS was conceived to address deficiencies impacting the personnel and pay entitlement support provided to military commanders. Approved in 1998, the Joint Requirements Oversight Council -approved Mission Needs Statement identified the following five requirements that DIMHRS must address:

- Provide Commanders-In-Chief with accurate and timely personnel data needed to assess operational capability.
- Employ standard data definitions across Services.
- Correctly track mobilized reservists.

- Provide accurate personnel tracking into and within a theater of action.
- Simplify data entry, system maintenance, and resolution of pay discrepancies.

The initial acquisition strategy developed by the PMO was flawed, and the strategy was suspended, pending review by the Joint Requirements and Integration Office under the Office of the Under Secretary of Defense for Personnel and Readiness. A viable strategy was defined during FY01 and the program is moving forward to implement that strategy. DIMHRS was initially stood up by the Navy Reserve Information Systems Office, but has since been transferred to a Joint Program Management Office operating under the Space and Naval Warfare Command.

### **TEST & EVALUATION ACTIVITY**

The PMO held several test and evaluation integrated process team meetings in FY01. A Test and Evaluation Master Plan was prepared and reviewed at a Test and Evaluation Summit in June 2001, but was missing several critical elements, and thus failed to garner OSD approval. The PMO subsequently withdrew that TEMP from review. A revised TEMP is being developed and should be completed in early 2002. There have been no test events for this program to date.

### **TEST & EVALUATION ASSESSMENT**

Since the Services have many unique personnel and pay policies and procedures, the success of DIMHRS is heavily dependent on the success of the business process reengineering in the functional areas of military personnel and pay. To implement a successful joint program like DIMHRS, the Service-unique functional requirements must be reduced to a minimum so that common core software can be used to effectively support all Services.



## **DRY CARGO/AMMUNITION SHIP (T-AKE 1)**

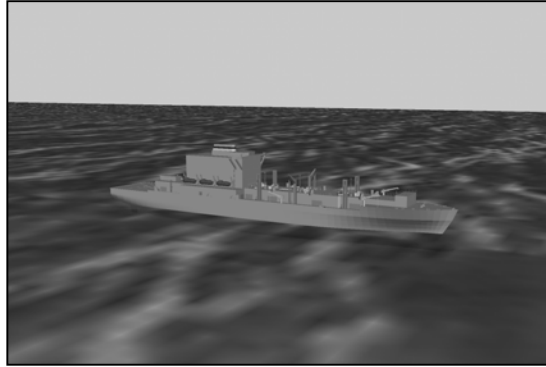

The Dry Cargo/Ammunition Ship program provides a new multi-product ship class to resupply Navy combat forces at sea. The ships will replace the existing auxiliary replenishment (AFS-Stores and AE-Explosives) class ships and will provide ammunition, spare parts, and provisions (dry, refrigerated, and frozen). The primary mission of T-AKE 1 is to provide logistics lift from friendly ports or from specially equipped merchant ships to the battle group replenishment station ships. In its secondary mission, the T-AKE 1 will be capable of remaining on station with the battle group to fill the station ship role in conjunction with a T-AO (Oiler)-class ship.

### **BACKGROUND INFORMATION**

By 2007, the entire Navy's current inventory of eight-ship AFS 1 class and eight-ship AE class will have reached the end of their 35-year design life. This 12-ship T-AKE 1-class is intended to replace these ships. The acquisition strategy prescribed a two-phased program. Phase I was to identify innovative concepts for efficiencies with on-board material handling and cargo flow and to propose life cycle cost savings through reduced manning and improved ship design. That phase has been completed. A contract for Phase II, the detail design and construction of the ships, was awarded in October 2001.

### **TEST & EVALUATION ACTIVITY**

During FY01, DOT&E continued to participate actively in the program's working integrated product teams and approved a Test and Evaluation Master Plan (TEMP) to guide planning for a three-phase operational test, assessment, and evaluation strategy.

In FY00, the Navy and DOT&E had developed the T-AKE program Live Fire Test and Evaluation (LFT&E) strategy. During FY01, the details on implementing that strategy were developed by the Navy and DOT&E, culminating in the definition of a LFT&E test program, approval of the T-AKE LFT&E Management Plan in August 2001, and the granting of a waiver from full-up, system-level testing by USD(AT&L). This alternative plan uses limited component, subassembly and surrogate testing, coupled with modeling and simulation (M&S) to conduct an assessment of selected shot lines that will identify ship and crew vulnerabilities. An at-sea Total Ship Survivability Trial will be conducted to assess T-AKE Class damage control and recovery.

## **TEST & EVALUATION ASSESSMENT**

A three-phase operational test, assessment, and evaluation strategy consists of two Operational Assessments (OAs) and an IOT&E for the lead ship of the class. The first OA, planned to commence in late FY02, will focus on the adequacy of planned cargo handling capabilities. Risks associated with cargo handling and flight operations for vertical replenishment will also be assessed. Because the ship will use Navy standard replenishment rigging, the risk of inadequate connected inter-ship replenishment capability is limited. Since the ship hull will be based on existing commercial designs, the risk of serious hull and propulsion deficiencies during routine operations is less than the risk associated with cargo handling at sea.

The initial OA will require accreditation of M&S by the Navy's OPTEVFOR. DOT&E continues to work with the Navy to ensure that the initial OA can provide assessment results that identify any design modifications, which are necessary from an operational perspective, and that support continuation of ship procurement.

The second OA will be conducted during the ship construction phase and will focus particularly on the performance of the ship and its components during scheduled testing, including acceptance trials by the Navy's Board of Inspection and Survey. The IOT&E will be conducted under realistic at-sea conditions, including replenishment of an aircraft carrier battle group.

An area, in which little information will be known, even after the completion of the T-AKE Class LFT&E Program, will be the resistance of vital equipment and structure to underwater explosive shock. While there will be an at-sea Total Ship Survivability Trial conducted to assess damage control and recoverability capabilities, there will be no ship shock trial because of concerns that many systems on the ship could be damaged beyond economical repair.

As the first ship built largely to commercial standards to undergo LFT&E, the management approach developed by the Navy and approved by DOT&E develops a test basis to assist in understanding the response of commercial grade structure and equipment to weapons effects. For the T-AKE 1 Class, the Navy has not established an operational requirement for shock hardening of vital mobility mission area equipment, or for other vital systems other than firefighting, emergency lighting, and communications systems.

## **E-2 AIRBORNE EARLY WARNING (AEW) HAWKEYE 2000**

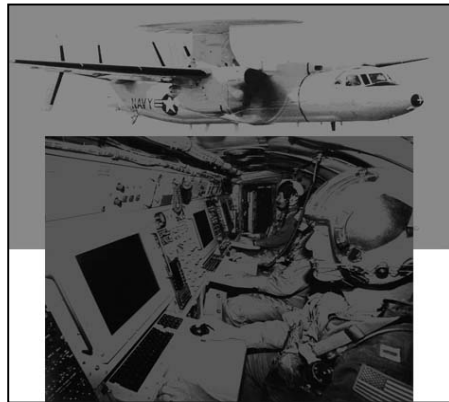

Hawkeye 2000 is an umbrella term for multiple improvements to the Group II E-2C. The improvements include: the replacement of the current mission computer with commercial-off-the-shelf computer (Mission Computer Upgrade [MCU]) and replacement of the control and display consoles with commercial-off-the-shelf workstations (Advanced Control Indicator System [ACIS]), the integration of the airborne variant of the Cooperative Engagement Capability (CEC) system, the addition of an upgraded inertial navigation system, an upgraded cooling system, UHF Satellite Communications (SATCOM), replacing the current Passive Detection System with an Electronic Support Measures (ESM) system, and development of a Mission Information Transfer System (MIST).

### **BACKGROUND INFORMATION**

The key objective of this series of modifications is the integration of Cooperative Engagement Capability (CEC). To carry the CEC, the E-2C required increased mission computing and display capabilities, as well as an offset in weight and volume. The modifications will be incorporated into new E-2C aircraft production. The Navy plans to retrofit these improvements into older E-2C aircraft.

In FY02, the Navy will start the Radar Modernization Program (RMP) for the E-2C. This program will replace the E-2C's radar with an UHF-Active Electronically Scanned Array (AESA) radar. This radar is intended to provide significantly increased performance over the current radar, particularly overland.

### **TEST & EVALUATION ACTIVITY**

MCU Technical Evaluation (TECHEVAL) was conducted from July to October 2000. During TECHEVAL, there were 18 test flights totaling 84.8 flight hours and approximately 350 hours of ground testing.

MCU OPEVAL was conducted from November 2000 to April 2001. An operational E-2C squadron, VAW-117, was designated the OPEVAL squadron, and received four LRIP MCU E-2Cs. The squadron employed the aircraft in normal operational training, exercise, and aircraft carrier deployment work-up flights. Prior to the start of the MCU Operational Evaluation (OPEVAL), there were one Part I and 17 Part II Deficiencies. Joint Interoperability certification was required prior to commencement of the MCU OPEVAL but was waived. COTF evaluated the MCU to be Operationally Effective/Not Operationally Suitable. During the OPEVAL, the ACIS was assessed potentially operationally Suitable.

## **TEST & EVALUATION ASSESSMENT**

There was no Beyond Low Rate Initial Production Report prepared for the MCU OPEVAL. Of the five Effectiveness COIs, COTF evaluated four as satisfactory: Tracking, Survivability, Tactics, and System Management. COTF found the Joint Interoperability COI to be partially resolved. Of the eleven Suitability COIs, COTF evaluated six as satisfactory: Reliability, Maintainability, Availability, Compatibility, Human Factors, and Safety. COTF evaluated Logistic Supportability, Training, Documentation, and Built-In-Test (BIT) Performance as unsatisfactory. COTF also found Interoperability to be partially resolved.

DOT&E did not concur with all of COTF evaluation. DOT&E found the COIs of Joint Interoperability unresolved instead of partially resolved as there was no test event in which the MCU-equipped E-2C demonstrated that it could effectively interface and operate with corresponding systems or units of other U.S. forces in the execution of its intended operational mission.

The E-2C entered OPEVAL without Navy or Joint Interoperability Test Command (JITC) Link 11 and Link 16 interoperability testing or certification. During the OPEVAL, there was not sufficient joint interoperability testing to adequately evaluate Link 11 or Link 16 interoperability. Also during the OPEVAL, the Navy Center for Tactical Systems Interoperability (NCTSI) completed an evaluation that identified one critical and numerous non-critical interoperability issues. After the conclusion of the OPEVAL, NCTSI tested software fixes to address the interoperability issues. Based on this testing of the software fixes, the Chief of Naval Operations authorized Interim Authority to Operate for the E-2C MCU Link 11 and Link 16 implementation for the first deployment only.

DOT&E differed in its assessment of the Tracking COI. This COI is assessed as unsatisfactory because during TECHEVAL the MCU E-2C, relative to the Group II E-2C, demonstrated a decreased capacity for real tracks. During OPEVAL there was no testing designed to test Track Loading. Although required in the MCU test plan, COTF did not report a calculation of Track Loading. Additionally, Suitability is a concern in that aircraft carrier power carts do not deliver constant and “clean” power for MCU E-2C start-up.

Logistic Supportability is a concern. Each MCU E-2C sortie requires a minimum of four Removable Media Cartridges (RMCs). The RMCs demonstrated a high failure rate during OPEVAL with 11 of the squadron’s 24 RMC failing. The majority of these failures (8 of 11) occurred during the 3 weeks of carrier operations, the primary operational environment. It is not possible for the squadron to repair a failed RMC and no data was recorded concerning the time it takes for the squadron to receive replacement RMC’s.

DOT&E disagrees with COTF’s assessment of the ACIS. While the ACIS met its maintainability requirement for Mean Time to Repair, it did not meet the Reliability requirement for Mean Time Between Failures (MTBF) of  $\geq 136.3$  flight hours and therefore is a suitability risk.

## **LESSONS LEARNED**

The MCU ORD discusses that the MCU hardware should comprise Commercial-Off-the-Shelf (COTS) components. Currently the MCU primarily uses Militarized COTS (MCOTS). There are indications that the MCU will be replaced when the RMP is implemented, implying that the MCU will not grow as the E-2C and COTS components grow. Instead, the MCU will rely upon outdated, hard to replace MCOTS hardware until the arrival of RMP.

This Page Is Intentionally Left Blank

## EA-6B UPGRADES



The EA-6B Prowler is a four-seat, all weather, twin turbojet powered, tactical aircraft designed to operate from aircraft carriers and airfields ashore. Its primary mission is the interception, analysis, identification, and jamming of enemy weapons control and communications systems in support of joint offensive and defensive operations. The crew includes one pilot and three electronic countermeasures officers. The EA-6B carries the ALQ-99 Tactical Jamming System (TJS), which includes the receiver, processor, and a selection of mission-configured jammer pods carried as external stores. Each jammer pod contains a ram air turbine generator, two selectable transmitter modules with associated antennas, and a universal exciter interfaced with and controlled by the On Board System (OBS) and aircrew. The modular open architecture of the jammer system optimizes transmitters and antennas for a given frequency range and tailors mission configurations. The EA-6B also has the USQ-113 Communications Jammer and may be armed with the high-speed radiation missile (HARM) for enemy surface-to-air radar destruction and suppression. The EA-6B supports aircraft survival through its contribution to the Suppression of Enemy Air Defenses (SEAD) Electronic Attack (EA) mission. Planned improvements include built-in-test capabilities to provide confidence in system readiness by maintenance personnel and system health by the aircrew.

### **BACKGROUND INFORMATION**

Operational since 1972, the EA-6B has undergone a number of upgrades: Expanded Capability, Improved Capability (ICAP), and Improved Capability II (ICAP II). ICAP II, including major upgrades to HARM employment and updated communications, was installed on operational aircraft in Operation Desert Storm. Another significant upgrade, Advanced Capability (ADVCAP), reached Full Scale Development in FY93 but was dropped from the FY95 Navy budget submission and subsequently cancelled. IOT&E of ADVCAP was completed in 1QFY94. This program provided the technical basis for much of the current upgrade program. EA-6B improvements that are currently in development, test, or production are:

- a) Block-89A upgrade, which attained Initial Operational Capability in 4QFY00 and is a pre-requisite for the Improved Capability-III (ICAP-III) upgrade discussed below.
- b) Improvements to the ALQ-99 jamming pod capability that include the Universal Exciter Upgrade (Full-Rate Production in 4QFY96), Band 9/10 transmitter (IOC 1QFY00), a prototype Band 7/8 jamming capability (derived from the in-production Band 9/10 transmitter), and the engineering and manufacturing development phase Low Band Transmitter (LBT) upgrades.

- c) ICAP III, which includes a new tactical receiver to provide a reactive jamming capability and replaces the current 1960s era receivers. Additionally, ICAP III systems integrate many of the above mentioned warfighting enhancements with the addition of new controls and displays, allowing improved crew operation. It includes provisions for Link-16, via the Multi-Functional Information Distribution System. ICAP-III builds upon the Block-89A improvements to achieve integrated receiver connectivity and reactive jamming/targeting capability through accurate geolocation of active emitters. The procurement plan is to transition all EA-6B aircraft to the ICAP-III configuration by 2010.
- d) The USQ-113 (Version 3) Connectivity Upgrade that improves the capability to jam enemy communications. Addition of the Multi-Mission Advanced Tactical Terminal and the Improved Data Modem capability improves battlefield situational awareness for the crew. The program is also integrating Aircrew Night Vision Devices (NVD) to enhance night capabilities.

### **TEST & EVALUATION ACTIVITY**

**USQ-113 Version 3.** DT was completed in April 2000. An Operational Test Readiness Review (OTRR) in May 2000 caused OPEVAL to be delayed until the program office addressed certain safety of flight issues involving the use of a laptop computer in the rear cockpit as an interface to the communications receiver/jammer capabilities. In October 2000, a second OTRR resulted in a successful certification for OPEVAL to begin. The first phase of OPEVAL began in January 2001 and completed in July 2001. COMOPTEVFOR's evaluation report is scheduled for submission in the near future. Upon approval of that report, 63 systems already produced will be fleet releasable. USQ-113 was already declared ready for Early Operational Capability in May 1999, and deployed to two fleet EA-6B squadrons in support of air operations over Serbia.

**Low Band Transmitter (LBT).** The Navy re-baselined the LBT upgrade to the ALQ-99 jammer in September 2000, slipping the program IOC from 3QFY04 to 2QFY05. MS III was extended from June 1999 to December 2001, and is now scheduled for FY04. During the program restructure, the Program Executive Officer (PEO) directed anechoic chamber tests of the transmitter/antennas. These tests took place in August 2000 with favorable results. EMD and DT&E activities continue to progress. Four EMD models are in production. The majority of 2001 T&E was contractor tests. An operational assessment (OA) is scheduled for the spring of FY03, prior to an LRIP decision scheduled for mid FY03.

**ICAP-III.** The Navy re-baselined the ICAP-III upgrade in May 2000 as a result of cost growth due to underestimating the complexity of the LR-700 receiver design, software, and development requirements. IOC slipped from 3QFY04 to 2QFY05. An LRIP decision is scheduled for early FY03, with an initial lot for 12 aircraft shipsets. There is a three month OA scheduled prior to the LRIP decision. A six month TECHEVAL follows to prepare for an OTRR in April 2003. OPEVAL is scheduled for July to November 2003.

### **TEST & EVALUATION ASSESSMENT**

Of the EA-6B upgrades, the ICAP-III program risk is centered on development of the LR-700 receiver; without it, ICAP-III does not offer significant combat capability enhancements beyond new displays. However, an adequate receiver design and software development profile will enable ICAP-III



to provide a much needed reactive jamming and accurate emitter geolocation capability in full azimuth coverage.

In a new development schedule, the program office incorporated an OA, which will be very beneficial in adding time to do some initial tests and fix the resulting discrepancies prior to OPEVAL. Since ICAP-III integrates new and old avionics supporting all mission roles of the weapons system, the final OPEVAL should be a robust, comprehensive, and challenging flight test of the improved complete EA-6B's ability to jam and launch HARMs in a composite force, multi-ship environment.

LBT chamber tests in August 2000 were completed with no catastrophic failures and an assessment by the program office that the few problems encountered (e.g., four antenna RF switch failures) can be resolved within current program cost and schedule constraints. However, Automatic Leveling Control (ALC) and some Built-In-Test (BIT) functions were not incorporated in the unit used for chamber testing. The LBT risk council has assessed Navy testing at risk since FCC restrictions may impact the ability to successfully pass OT. Antenna development and function are also risk items.

USQ-113 Version 3 has completed OPEVAL and provides a greatly needed replacement for the Version 2, which is becoming not operationally mission capable due to a lack of replacement parts. The lack of an Operational Requirements Document for this congressional "plus up" funded program, has resulted in a complicating dearth of requirements definition. Preliminary results from the OPEVAL are that Version 3 has been found deficient in four areas: (1) the presence of the laptop remains a safety issue; wear and tear could nullify some of the measures taken in preparation for the October 2000 OTRR; (2) deficiency in display brightness control affects aircrew operations; (3) Windows based operator/software interface and system architecture complexity requires an inordinate reliance on the use of capability limiting special operating procedures; and (4) a classified function does not function correctly, and when operated it reduces overall system effectiveness.

The Block 89A and the Night Vision capability have been significant upgrades. The initial USQ-113 V3 units were sorely needed for V2 units that had no replacements, but its endorsement retains several caveats. The contributions of the LBT pod are yet to be demonstrated (test limitations are still being addressed). ICAP III, with the new LR-700 receiver, has recently been delivered to NAVAIR and will begin government testing.

This Page Is Intentionally Left Blank

## **EVOLVED SEA SPARROW MISSILE (ESSM)**



The Evolved Sea Sparrow Missile (ESSM) is a short-range missile intended to provide self-protection for surface ships. On Aegis ships, ESSM will be launched from the MK 41 Vertical Launch System. Four missiles are stored, with tail fins folded, in each launcher cell. Vertical launch requires a thrust vector control system on the ESSM rocket motor. Guidance will be by up-linked commands until the ESSM is near the target, at which time guidance will transition to semi active homing on reflected radar signals from the target. ESSM may also be launched in a home-all-the-way mode (no up-linked commands). At this time, ESSM installation is funded for Aegis ships only. On non-Aegis ships (aircraft carriers, amphibious assault ships, other surface combatants), it will be fired from other launch systems; guidance will be in home-all-the-way to intercept. ESSM uses an 8-inch diameter modified guidance section and a new warhead section. This forebody is attached to a new 10-inch diameter rocket motor, which provides higher thrust for longer duration than predecessor Sea Sparrow missiles. ESSM is a cooperative development effort by thirteen participating governments.

### **BACKGROUND INFORMATION**

Milestone II was conducted in November 1994. During 1998, the program was restructured with an OA based on missile flights at White Sands Missile Range (WSMR), NM, to support the initial LRIP decision. A second LRIP decision was added and will be supported by testing with the Self Defense Test Ship (SDTS). The full production decision will be supported by an OPEVAL, planned for FY03, conducted with an Aegis destroyer. Subsequent to program restructuring, the TEMP was revised and approved by OSD in March 2000. LFT&E component/section level ground testing, conducted in FY96-FY98, included arena tests and fragmentation mat tests against components of U.S. and foreign targets.

### **TEST & EVALUATION ACTIVITY**

FY01 activity included final test flights for the DT at the WSMR, NM. This included the last two guidance test vehicles (GTVs). The GTV results served as the basis for an OA to support an LRIP decision. Tests were conducted in accordance with a DOT&E-approved TEMP and OA plan.

Activity also included two firings for the developmental Aegis S-Band testing at the WSMR, with the third scheduled for November 2001. Additionally, the first two at-sea ESSM firings were conducted in April and September as combined DT/OT on the SDTS. Both the S-band and SDTS tests

were conducted in accordance with a DOT&E-approved TEMP and test plan. The TEMP is being revised in preparation for the OPEVAL.

The Live Fire Test and Evaluation IPT was constituted in FY01, met for the first time in May, and is tasked with producing the Navy's assessment of ESSM lethality to support the full-rate production decision.

## **TEST & EVALUATION ASSESSMENT**

GTV phase (DT supporting OT-IIA): Three GTVs were flight-tested during FY00, and the last two (GTVs 4 and 5) were fired in early FY01. GTV-4 was launched from a vertical launcher at a subsonic, maneuvering target, with successful intercept at medium range and low altitude. GTV-5 was launched from a vertical launcher at a subsonic target, with successful intercept at close-in range and low altitude. Two of the FY00 GTVs experienced loss of radomes during terminal guidance. GTVs 4 and 5 used radomes from a different manufacturer and both radomes survived. These tests demonstrated ESSM capability against various ASCM-like targets while using home-all-the-way guidance.

S-Band Testing (DT supporting OT-IIB): The Aegis S-Band testing is intended to demonstrate missile launch from the MK 41 vertical launching system with mid-course guidance provided by up-linked S-Band commands from a simulated Aegis radar. Terminal guidance is provided by semi active homing. The first two (of three total) missile flight tests were conducted successfully. As of this writing, the final missile flight test is scheduled for early 2002.

Self Defense Test Ship Phase (OT-IIC). The combat system installed on the SDTS is intended to approximate that on non-Aegis ships that use the MK 29 rail launch system. However, the combat system on the SDTS has limitations that constrain ESSM capability against some operationally realistic threats. As a result of better understanding the impact of these limitations, certain missile firing scenarios planned for the SDTS phase are being modified and moved to the OPEVAL with an Aegis destroyer. The TEMP is being updated to reflect these modifications. The first two firings conducted from the SDTS experienced in-flight failures as the missiles evidenced loss of control, caused by failure of the locking pins that are supposed to keep the unfolded tail fins erect. A flight test in late November 2001, using non-folding fins, resulted in the missile executing an inertial midcourse guidance phase, followed by terminal homing on and destruction of the target. Folding fins with redesigned locking pins will be flight tested during the late January 2002 timeframe. Also observed during the initial ESSM firing from the SDTS was severe noise introduction into the signal processor attributed to rear reference signal modulation by the rocket motor exhaust plume. Investigation continues to design an interim fix to mitigate the rocket motor plume noise. Additionally, investigation has been expanded to look for other possible causes of noise introduction into the signal processor.

OPEVAL and FOT&E. Adequacy of the FY03 OPEVAL is dependent upon operational realism of the scenarios. These scenarios are being defined as this is being written. Given the low and dwindling inventories of threat-representative targets (maneuvering supersonic sea-skimmers and supersonic high divers); they may not be available for the OPEVAL; and without them, we would be unable to approve the OPEVAL test plan for adequacy.

For FOT&E, a new anti-ship cruise missile (ASCM) threat has appeared for which there is no credible surrogate target. Given the time required to obtain such a surrogate, this is expected to be an issue for FOT&E. Additionally, limitations in the Aegis Weapon System Baseline 6.3 computer program and shipboard illuminator radars will preclude testing ESSM's capability against surface targets.

Although this is not a requirement, it is a capability provided by predecessor Sea Sparrows on non-Aegis installations.

ESSMs are intended to provide close-in defense of Aegis ships against ASCMs, with Standard Missile providing interceptor capability at longer ranges (both self defense and defense for other ships). There are circumstances where the Aegis Weapon System could be controlling ESSMs and SM-2s simultaneously. This is primarily an Aegis Weapon System (Baseline 6.3) issue that requires operational testing under the DDG-51 program's FOT&E.

LFT&E. The LFT&E strategy is structured around component/section level ground testing, actual missile firing results against ASCMs and surrogates, computer modeling, and simulation analyses. The IPT is finalizing reports of test results. In planning for the collection of lethality data during OT missile firings, the IPT is considering adding low-cost target instrumentation to ESSM flight test targets to record warhead detonation and fragment strikes on target components. The IPT is also currently examining simulation tools and target models that will be used for lethality analyses.

This Page Is Intentionally Left Blank

## **EX-171 EXTENDED RANGE GUIDED MUNITION (ERGM)**

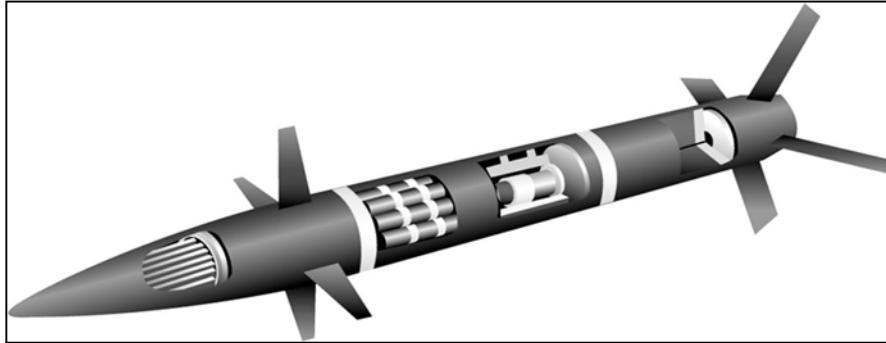

The EX-171 Extended Range Guided Munition (ERGM) is a gun launched 5-inch, rocket-assisted, cargo projectile which carries and dispenses 72 EX-1 Dual-Purpose Improved Conventional Munitions (DPICM) grenades over the target in a preset impact pattern. The DPICM grenades damage the target through either fragmentation or shaped-charge jet penetration. Using a special high-energy propelling charge (EX-167), it is designed to extend Naval Surface Fire Support (NSFS) to ranges beyond 40 nautical miles. The ERGM is a precision-guided munition that uses a coupled Global Positioning System (GPS) and Inertial Navigation System (INS) guidance system and aerodynamic flight control surfaces to steer the projectile to the pre-selected payload expel/dispense point.

The ERGM is designed to provide highly responsive precision engagement of threats to U.S. Marine Corps or U.S. Army ground combat forces operating ashore, prior to the establishment of organic fire support assets, and to supplement organic field artillery once it is ashore.

### **BACKGROUND INFORMATION**

The ERGM Operational Requirements Documents (ORD) and Test and Evaluation Master Plan (TEMP) were approved in FY96, prior to a Milestone II decision that also occurred that year. The development program encountered significant technical hurdles soon thereafter. In particular, difficulties were experienced with hardening sensitive components of the GPS-INS guidance system to the accelerations experienced in gun-launch, developing a mid-body obturator band (seals the propelling charge gases) and the functioning and lethality of the developmental EX-1 DPICM grenades. Also, design flaws were discovered in the baseline rocket motor design. The program notified the acquisition executive that it expected to breach the acquisition program baseline in FY98. The program was restructured, and a new acquisition decision memorandum was issued in FY00. The original (FY96) ERGM ORD and TEMP have not yet been updated but are currently undergoing review and revision with DOT&E participation.

### **TEST & EVALUATION ACTIVITY**

The program is currently conducting developmental testing. A limited functionality control test vehicle (CTV-1) was successfully launched in early FY01. The current plan calls for several more flight test events prior to the Critical Design Review. This will be followed by a formal qualification program

consisting of performance, safety, and environmental testing. These events will also be used to help assess the validity of several models and simulations under development to supplement operational testing by COMOPTEVFOR. TECHEVAL is scheduled for 2QFY04, followed by OPEVAL scheduled for 1QFY05.

## **TEST & EVALUATION ASSESSMENT**

The ERGM is a single component of a very complex NSFS system. Timely target acquisition, fire support coordination, and terminal performance of ERGM are special areas of concern for this system. DOT&E's objective is to exercise the entire naval fire support system in a realistic manner in order to evaluate the operational effectiveness, suitability and lethality of the ERGM round.

Naval gunfire range limitations pose a substantial challenge to realistic operational testing. No current NSFS test or training range will allow engagement of realistic targets with live ERGM rounds because of the large hazard footprint. DOT&E is examining alternative analytical evaluation approaches proposed by COMOPTEVFOR that link shipboard firing of inert submunition or telemetry rounds, and land-based firing of live tactical rounds against realistic targets.

Because there is no warhead-compatible telemeter available, developmental testing of ERGM is conducted by firing the round with either the tactical submunition payload or the instrumentation section. Since this does not allow for full-system evaluation from a single round, additional test rounds are required. DOT&E is assisting the program office in attempting to integrate a warhead-compatible Hardened Subminiature Telemetry and Sensor System technology into the ERGM projectile. If this approach proves successful, the mix of tactical and instrumentation rounds previously described for OPEVAL may be altered.

Emerging data and analyses recommend closer examination of the lethal effects of extremely small fragments from DPICM and other submunitions. DOT&E will evaluate the lethality of the EX-1 submunitions against the full range of expected personnel and materiel targets in realistic operational environments.



## F/A-18 E/F SUPER HORNET



The F/A-18E/F Super Hornet (E/F) is a multi-mission, day/night strike fighter aircraft that provides strike capability to Joint Task Force and Carrier Battle Group Commanders. The E/F features improvements in range, endurance, carrier bring-back, weapon payload, and survivability. It also provides in-flight tanking for other tactical aircraft, and additional room for growth and upgrades.

Three major upgrades to the E/F are planned: an Active Electronically Scanned Array (AESA) radar, an Advanced Targeting Forward Looking Infrared (ATFLIR) sensor, and an Advanced Crew Station (ACS) in the two seat F/A-18F aircraft. AESA, the APG-79 radar, significantly increases E/F capabilities. It is designed to improve aircraft lethality, survivability, and enhance signature characteristics. It corrects current APG-73 radar deficiencies, including a lack of capability for growth, while allowing near-simultaneous operation of different radar modes. In conjunction with the ACS, AESA permits new workload strategies within the two-seat “F” cockpit by allowing each crewman to perform different mission functions independently. For example, the pilot might concentrate on air-to-air while the Weapon Systems Officer concentrates on air-to-ground.

ATFLIR represents the latest generation of technology in infrared targeting capabilities, including navigation FLIR, laser spot tracker, air-to-air laser ranging, electronic zoom, geographic-point targeting, and Electro-optics. The existing FLIR pod has documented deficiencies in high altitude magnification and resolution that degrade and, in some instances, preclude target location and precise aimpoint selection. ATFLIR incorporates sensor technologies designed to correct these deficiencies. This next-generation technology is designed to provide three fields of view, incorporate a larger detector array, and allow flight operations up to 50,000 feet altitude.

ACS introduced design and structural changes to the F/A-18F aft cockpit when the Navy decided to retire the two-seat F-14 and replace it with the F/A-18F. The two-seat F/A-18F was initially designed and produced as a trainer for single-seat F/A-18E pilots. Aft cockpit displays and controls replicated those of the front cockpit so that an instructor pilot had the same information as the front-seat student pilot. The most significant ACS change decouples rear seat displays and functions from the front seat so that the Weapons System Officer (WSO) can perform functions independent of the front seat pilot. A redesign of the main instrument panel increases multi-function display area. A Digital Video Map Computer provides a high-resolution map on the 8 x 10 display to increase WSO situation awareness. Secondary Hardware-Software Integration, the situational awareness (SA) format, and secondary sequence lines allow independent control in each cockpit. The pilot and WSO can independently view

maps giving each the display they need to perform separate but complementary functions, particularly in a combat environment.

## **BACKGROUND INFORMATION**

### **AIRCRAFT**

OPEVAL on the E/F was conducted from May to November 1999. In April 2000, DOT&E's B-LRIP report to Congress found that the E/F was operationally effective and operationally suitable. Several OT issues relating to missing or deficient systems required further attention:

- Not all stores combinations intended for use by the E/F were cleared for carriage and release during OPEVAL. While the configurations available were extensive for this phase of testing, there were numerous restrictions involving weapon type, weapon quantity, release interval, multiple release and mixed loads that were not available during OPEVAL.
- Due to an increased noise and vibration environment discovered under the wing of the E/F during developmental testing, a variety of stores and air-to-air missiles in particular required additional and more frequent inspections to help ensure acceptable reliability.
- The full potential of the E/F will be realized only after the incorporation of several new subsystems on the Navy's roadmap for the aircraft, especially the Joint Mounted Helmet Cueing System (JHMCS), the AIM-9X missile, and ATFLIR.

### **AIRCRAFT UPGRADES**

AESA Milestone II was conducted in February 2001. The IOC of AESA is scheduled for late 2006. Because of the potential significance of AESA, DOT&E placed it on oversight for both OT&E and LFT&E. AESA requires several significant structural changes to the aircraft's forward fuselage and cooling system. An umbrella LFT&E program that evaluates the modified aircraft structure with all changes incorporated is under consideration.

ATFLIR. First flight of the ATFLIR pod and start of the DT-IIB Test Phase occurred in November 1999. OT-IIA, an operational assessment, was conducted in June/July 2000 and documented several major deficiencies that required corrective actions. In September 2000, schedule and design changes to the Electro-Optical Sensor Unit were implemented to reduce program risk from high to medium in schedule, cost and performance. OT-IIB, an Operational Assessment period, is planned for 2002 using refurbished Engineering Development Model ATFLIR pods in preparation for a planned Early Operational Capability with the first deployment of the F/A-18E aboard the USS Abraham Lincoln (CVN-72) in 2002. OPEVAL of the ATFLIR is scheduled in FY03, using units that incorporate changes anticipated to make them fully compliant with requirements.

ACS. The first flight of an ACS aircraft is scheduled for FY03, with installation beginning in Lot 26 aircraft to be delivered in CY04 and fleet deployment in Lot 27 aircraft in late CY05.

## **TEST & EVALUATION ACTIVITY**

### **FOT&E (1) -- FIRST PERIOD OF AIRCRAFT FOLLOW-ON OPERATIONAL TEST AND EVALUATION**

DOT&E approved the TEMP and Test Plan. Aircraft FOT&E (1) began in September 2001 and is scheduled to finish in April 2002. The aircraft's tactical software was upgraded to Software Configuration Set 18E (SCS-18E). This software upgrade plus the addition of new systems and new munitions requires more sorties to support FOT&E (1) than were flown during OPEVAL.

The objectives of FOT&E (1) are to:

- Determine the operational effectiveness and operational suitability of the E/F aircraft with SCS 18E installed.
- Evaluate items that were waived from OPEVAL that are now ready for test.
- Evaluate corrections to deficiencies identified in OPEVAL.
- Complete evaluation of Critical Operational Issues (COIs) that were only partially resolved during OPEVAL.
- Investigate potential new tactics for use with the E/F.

During OPEVAL, the Navy approved 50 waivers to the testing of required capabilities. For FOT&E (1), 30 of those waivers were declared ready to test with no additional waivers. FOT&E (1) also initiated OT of two new systems in addition to SCS 18E: a Positive Identification System (PIDS) and JHMCS. In December 2001, OT of the E/F as a carrier-based tanker was conducted. Two munitions began OT: Joint Direct Attack Munition and the Joint Stand Off Weapon with operational assessments of the ATFLIR and MIDS.

### **AIRCRAFT UPGRADES**

AESA developmental testing focused on a number of prototype modules or components to reduce specific design risks identified by the several Integrated Product Teams that are responsible for specific AESA components during FY01. This testing supported the conduct of a series of design reviews for each of the major subsystems, culminating in the successful conduct of a Critical Design Review in October 2001 for the integrated AESA design.

## **TEST & EVALUATION ASSESSMENT**

### **AIRCRAFT**

The E/F B-LRIP Report noted that one of the principal reasons underlying the upgrade to the E/F is the capacity for growth to accept further improvements and to correct deficiencies in key subsystems of the F/A-18C/D. DOT&E also reported that the E/F must incorporate several key improvements to realize its full potential and operational capabilities. FOT&E (1)'s wide array of potential improvements indicates that the necessary growth process is underway. DOT&E is monitoring FOT&E (1) and will provide an evaluation of the test results in next year's Annual Report.

## **AIRCRAFT UPGRADES**

AESA is on track to increase performance of the E/F. DT activity to date includes laboratory bench testing of prototype array modules and an assessment of the anticipated array performance using modeling and simulation of a completed array using the bench testing results. Simulation results indicate that AESA will meet requirements. The accuracy of this simulation in a similar antenna program has been demonstrated. DOT&E will monitor this effort as hardware becomes available for OT assessment. Early OT involvement supports full integration and compatibility of five new systems or modifications: the Advanced Mission Computer & Displays, Fiber Channel Network Switch, Software Configuration Set High Order Languages, Advanced Crew Station and the structural modifications to the aircraft's avionics cooling system. The LFT&E evaluation of the Common Block 2 E/F AESA aircraft effort will be an incremental LFT&E update based on the E/F EMD aircraft program.

ATFLIR OT-IIA identified ten major deficiencies affecting the sensor performance, E/F compatibility, and interoperability with other E/F systems. Four have been fixed as verified by DT flight test; three have been significantly improved as verified by DT flight test. Of the remaining three deficiencies, a change has been incorporated to correct observed jumps in the Line of Sight, but remains to be verified in DT/OT and the root cause of the two remaining deficiencies under investigation. Concurrent with FOT&E (1) of the E/F, OT-IIA of the ATFLIR in 2002 will provide an operational assessment of the Engineering Development Model pods refurbished to incorporate these corrections. Although these refurbished pods will have some carriage limits not representative of the production pods, e.g., limited to 5 Gs, this testing will provide an early look at how the design changes have improved the operational effectiveness and operational suitability of this system.

## INTEGRATED DEFENSIVE ELECTRONIC COUNTERMEASURES (IDECM) AN/ALQ-214

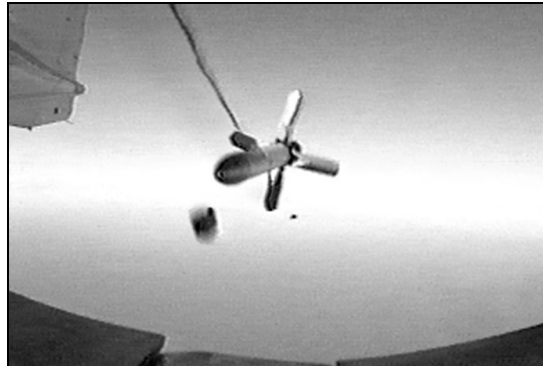

The Integrated Defensive Electronic Countermeasures (IDECM) is intended to provide self-protection and increased survivability for tactical aircraft against radio frequency (RF) and Infrared (IR) surface-to-air and air-to-air threats. The major hardware component to be developed by the IDECM program is the IDECM radio frequency countermeasures (RFCM) system and the ALE-55 Fiber Optic Towed Decoy (FOTD), which is trailed behind the aircraft to optimize RFCM techniques against threat missiles and tracking/targeting systems. The RFCM consists of an on-board receiver/processor/techniques generator that stimulates the FOTD via fiber optic cable or on-board transmitters for transmission of the countermeasure technique. The FOTD is intended to be deployed from the T-3F launch controller, also used with the ALE-50 Advanced Airborne Expendable Decoy (AAED).

In addition to RFCM and FOTD, the IDECM lead aircraft (F/A-18E/F) will integrate the radar warning receiver, a missile warning system, the ALE-47 chaff/flare dispenser, and an off-board decoy launch controller/dispenser. In FY99, the Navy decided to add an on-board jamming capability to provide a full self-protection capability throughout the entire operational flight envelope of tactical strike aircraft. Even if operational maneuvers or engagements deplete the limited number of FOTDs carried, the platform will still have a capable self-protection suite. Upon completion of its own OPEVAL, the Advanced Strategic Tactical Expendable is one of several expendables that may be dispensed by the ALE-47.

IDECM Block I is an interim system consisting of the ALQ-165 Advanced Self-Protection Jammer (ASPJ) and the ALE-50 AAED. The Navy plans to use the IDECM Block I configuration for the first three F/A-18 E/F operational deployments only.

IDECM Block II, a second interim configuration, will replace the ASPJ with the ALQ-214 (V)2, providing on board jamming capability. This configuration is planned for the fourth and fifth F/A-18 E/F deployments.

IDECM Block III will be the final configuration and will consist of the ALQ-214 (V)2 RFCM and ALE-55 FOTD.

## **BACKGROUND INFORMATION**

IDECM was intended for the first F/A-18E/F operational deployments in 2002. USAF requirements for a common FOTD and techniques generator were included in the IDECM RFCM engineering and manufacturing (EMD) contract. USAF has selected components of IDECM RFCM for the B-1B Defensive System Upgrade Program, and is planning integration into the F-15 ALQ-135 Tactical Electronic Warfare System architecture. In 1998, IDECM was re-baselined to fund an 87 percent development cost overrun and extend the development six months. In April 1999, technical difficulties and cost overruns resulted in a second restructuring by the Program Executive Officer (PEO(T)). The resultant strategy is a three-phased, sequential approach intended to meet early operational deployment requirements and reduce the development risk of the final IDECM suite.

On a parallel schedule, the Navy conducted the F/A-18E/F OPEVAL from 3QFY99-1QFY00. Since this OPEVAL was conducted before any of the IDECM blocks were available, aircraft were equipped with the ALE-50 Launch Controller/Dispenser portion of IDECM Block I, including AAED. This (effectively Block 0) configuration fulfilled the initial self-defense requirement in support of the overall F/A-18E/F survivability requirement.

IDECM Block I DT, Sep 99 through Feb 00, tested ASPJ installation, effectiveness and suitability on the F-18 E/F to include compatibility with other self-protection systems (ALE-50, ALE-47, and ALR-67 (V)3). The successful initial DT of IDECM Block I led to a combined DT/OT test conducted in March to April 2000, and an independent OT, conducted May to August 2000. The operational effectiveness criteria was a measurable reduction in lethality for the Block I equipped F/A-18 E/F as compared to an ALQ-126B equipped F/A-18 C/D. DT and OT included hardware-in-the-loop simulations and flights involving actual threat systems. Block 1 was found to be effective and suitable. Of particular note was that there were no ASPJ failures in 152 hours of flight testing and the BIT false alarm rate was zero.

IDECM Block II completed a limited DT Assist by operational test personnel in 4QFY00. The results indicated positive progress towards a Block II fielding in the fourth F/A-18E/F deployment in August 2003. Technical delays and budgetary shortfalls have delayed the test and procurement of the Block III configuration, originally scheduled to occur concurrently with the Block II configuration.

Block III completed a limited (no on board transmitters) Operational Assessment (OA) in March 2000, in which it was assessed to be potentially operationally effective and suitable. The IDECM Block III RFCM OA was conducted in two phases. A hardware-in-the-loop (HITL) test versus a realistic threat system was conducted in November 1999. The aircraft, missile flight path, and environmental effects were modeled using an uninstalled RFCM and FOTD to counter a missile in a radar anechoic chamber. The second OA phase was flight testing at NAWC-WD China Lake's Electronic Combat Range, carried out February-March 2000. This test phase provided an early look at the potential operational effectiveness and suitability of IDECM. By design, the test was limited to a non-production representative installation on a test bed aircraft using a reel-out, reel-in external pod to conserve decoys.

## **TEST & EVALUATION ACTIVITY**

Test and evaluation activity of Block II/III during FY01 was beset by technical difficulties with the FOTD and launcher assembly, the receiver signal tracking capability, and system integration. Developmental testing revealed unexpected FOTD flight envelope and IDECM component interoperability issues. System development was at a much slower pace than expected, and led to

multiple delays in the DT/OT and OPEVAL. Fast deploy (a rapid release and reel out to a specific distance behind the aircraft) testing was carried out on F/A-18 E/F, B-1B, and F-15E aircraft. Multiple iterations of the canister and towline were evaluated. To resolve safety of flight issues caused by FOTD fins striking the underside of the aircraft, a fin delay mechanism was developed and tested. Developmental flight testing continued throughout the end of the fiscal year. Software and software integration appear to be on track, although integration with the RWR has proved difficult. However, due to the by-design deployment of the FOTD in the area of the engine plume, the F/A-18 E/F continues to be the most difficult platform for IDECM.

Several efforts were made to improve decoy deployment and retention on the F-18E/F. Materials research studies, to improve the thermal and mechanical limits on new fiber optic and towline strength member materials, were continued. A final signal and strength member configuration for the tow-line was selected. In addition, two efforts to improve the current version of the reel-out, reel-in pod for test use were completed. These improvements are needed to improve the rate of decoy re-use and expand the flight envelope over which the decoy can be tested.

The ALQ-214 (V)2 and FOTD were tested at two HITL facilities Radio Frequency Simulator System (RFSS) and the Air Force Electronic Warfare Evaluation Simulator (AFEWES) against the missile seekers of four threats. Preliminary results from the tests indicate excellent performance of the FOTD versus these four systems. The performance was in line with expectations, indicating the system is functioning against each of these threats as intended.

Technical and budgetary shortfalls led to a restructuring of the program at the end of the FY01. Test aircraft availability, continued difficulties with fast deployment of the FOTD decoys, and unplanned iterations of the software to correct integration and effectiveness problems, revealed during lab and flight testing, all led to these shortfalls. The Block II configuration alone will be tested during the DT/OT 1QFY02 and the subsequent OPEVAL. A few flights with the revised towline configuration will be flown 1QFY02, but the majority of Block III testing will be done in FY03 and FY04.

## **TEST & EVALUATION ASSESSMENT**

The approved TEMP is dated April 1999. It was approved by DOT&E with the condition that it was valid only through the IDECM RFCM OA and that the TEMP will be updated prior to the next OT test event. Annex A to the TEMP covering all Block I test efforts was approved in March 2000. The TEMP IPT has updated the capstone and Block II TEMP annexes to include the first two phases of IDECM development, testing, and introduction to the Fleet. This version of the TEMP, complete through the testing of IDECM Block II, was signed by ASN(RD&A) 1QFY02. With revisions caused by the separation of the Block II and Block III test phases, it will be submitted to USD/AT&L and DOT&E shortly. The development and testing of Block III will be covered in a subsequent Annex to the TEMP.

The new three-phase development strategy and test planning have successfully mitigated some of the risk incurred over the last three years of IDECM evolution. As mentioned earlier, Block I is presently on track to support the first three F-18E/F deployments. The IDECM Block I test effectively re-baselined survivability of the F/A-18E/F. The Block I system, by virtue of being an interim solution, has limited logistic supportability for the fleet. The Navy has not sought to change or extend the ASPJ logistics support structure. Follow-on IDECM blocks must produce an effective and suitable replacement to the Block I suite before its available logistics support expires. Block II DT results look promising; however, operational tests of Block II have yet to be conducted.

Block III, particularly the FOTD, towline, and deployment design, is still high risk. In the lab environment, the Block III RFCM and FOTD have proved to be a highly effective system. Results in the HITL tests versus realistic threat systems were very positive, and also very close to predicted results. Once the flight envelope in which the system could successfully deploy and maintain fiber optic continuity was determined, the IDECM OA flight test was successful. The results of the test proved – in the very limited maneuver, altitude, and airspeed regime explored – that the RFCM and FOTD could be effective against several distinctly different types of SAMs. However, the hardware and software installations were non-production representative and, therefore, little could be determined in the OA about suitability. DT flight test results with regard to suitability are very promising; however, a number of repeated system BIT failure indications were removed from scoring because corrective actions are underway.

Several test range limitations have hampered all blocks of IDECM testing. Some threat simulators intended for use during the RFCM OA were not operational. One new test asset, the “Missile on a Mountain,” used for testing a particular class of missiles, did not produce consistent miss distance data. Daily alignment variations of several of the threat simulators made analysis and interpretation of the results difficult. Furthermore, only a small number of threat assets available have accredited fly-out models that work in real-time profiles. The situation has improved slightly for the DT/OT and OPEVAL, but needs further improvement. The Navy needs to invest in these test assets, to include valid fly-out models and accreditation of as many threats in the IDECM threat matrix as possible, in order to produce operationally relevant and credible T&E results for Block II and Block III variants.

The Navy needs to continue developmental efforts to produce a reliable IDECM system, solve decoy launch/flight envelope issues, and gain further insight on towline characteristics and failure conditions. Despite the hopes for a successful Block III program, a rigorous and comprehensive operational test of the Block II configuration will be required before fielding the system for interim use. It is especially important to do this, in case the Block III (ALE-55 FOTD) is not acquired.



# JOINT MARITIME COMMAND AND CONTROL CAPABILITY (JCC(X)) SHIP



JCC(X) is the Navy's proposed replacement capability for the current four aging command ships. The new ships should provide Joint Force Commanders and embarked component commanders with enhanced mission capability for joint campaign battle management employing advanced command, control, communications, and computer integrated systems. The details of how the required capabilities will be provided are currently being defined, based on a recently completed Analysis of Alternatives (AOA). Candidate configurations include Joint Command and Control functions aboard dedicated built-for-the-purpose ships, converted ships, or distributed among a number of platforms. Both alternatives include a reach-back capability to ashore facilities that support the on-site force commander.

## **BACKGROUND INFORMATION**

The Navy currently operates four dedicated command ships, which have been in service for 27 to 36 years. The replacement ship class will operate in much different combat operational environments from those for which the existing ships were built. The information revolution is changing operational concepts for military and naval forces, and U.S. forces operations are now required to be jointly interoperable, as well as increasingly interactive with allied and coalition forces as well as non-defense agencies and organizations.

The JROC validated the Mission Need Statement for JCC(X) in September 1999 and the USD(AT&L) granted Milestone 0 approval in November 1999.

OSD guidance for the AOA called for a two-part assessment. Part 1 addressed whether an afloat command capability will be needed in the future. Part 1 findings are:

- An afloat JCC capability will be an essential element of robust operational-level command and control for joint operations in the future.
- The mix of dedicated and distributed JCC capabilities should be examined further in Part 2 of the AOA.

Part 2 of the AOA was completed in FY01. This study considered the required C4ISR operational functions and queried several of the current operational and joint command staffs in the process of

developing alternatives. Implications of alternatives in the following areas were presented for Navy decisions:

- Division of C4I functions between the command ship and reachback to staff elements in secure locations ashore. Those decisions interact with choices for the optimal number of staff personnel to be accommodated on-board ship.
- Anticipated future technologies and their effect on staff size and organization.
- Number of ships required to meet responsiveness criteria and hedges to reduce risks.
- Ship characteristics, particularly survivability features, maximum speed, and whether the ship should be crewed entirely by Navy personnel, or by a combination of Military Sealift Command and uniformed personnel.

The Program Initiation Decision Review (PIDR), in lieu of a Milestone 1 DAB, is expected in FY02. The ORD, required at the PIDR, has yet to receive Navy Requirements Oversight Council concurrence prior to JROC approval. The PIDR, the Evaluation Strategy, Acquisition Program Baseline, Command, Control, Communications, and Computer Integrated Support Plan (C4ISP) and a preliminary cost analysis are also required.

### **TEST & EVALUATION ACTIVITY**

DOT&E has participated in the Joint Oversight Group discussions of the AOA, but the immaturity of this program has not permitted specific test and evaluation activities during this year.

### **TEST & EVALUATION ASSESSMENT**

Since the joint command capability may be distributed between the ship and other facilities afloat and ashore, the JCC(X) ship capability itself could contribute only a partial-response to the overall C4ISR task requirements. Determining the effectiveness of the integrated command and control systems entity and the contribution of the JCC(X) within that structure will be a substantial challenge and it will require evaluation of the distributed elements of C4ISR as well as the JCC(X). Evaluating the suitability, effectiveness, and survivability of any facility and/or platform, which will house the JCC(X), will be a further challenge.

The operational assessment of the JCC(X)'s suitability, effectiveness, and survivability will focus on the JCC(X) capability, not just the ship platform and operations in its intended environment.

## JOINT MISSION PLANNING SYSTEM (JMPS)



The Joint Mission Planning System (JMPS) provides computer tools to aid in planning aircraft missions. It will consist of computer hardware using common core software called the Joint Mission Planning Environment (JMPE), combined with Unique Planning Component (UPC) software that supports the particular aircraft or user. JMPS is intended eventually to support most DoD aircraft, weapon, and sensor assets.

JMPS hardware is expected to range from laptops with minimal computing resources, to desktop systems, to multi-processor workstations with substantial computing resources. The minimum required hardware package will be defined by each individual aircraft program office. JMPS user systems will include both stand-alone configurations and systems connected via multiple networks. JMPS is required to have the capability to update local data bases from remote data sources, disconnect from the network, and continue to support mission planning (i.e., load-and-go). Portable JMPS systems (e.g., laptop) will typically use this capability when deployed to remote locations.

As an evolutionary acquisition, JMPS starts with a baseline capability and grows with the addition of enhancements. Version 1.0 of JMPS, which provides basic mission planning capabilities, is required to have, as a minimum, the capability available in the Air Force Mission Support System (AFMSS) program's Portable Flight Planning Software (PFPS), Version 3.2. The first user of JMPS Version 1.0 will be the B-52H, which will employ JMPS, as PFPS is currently used, to develop basic flight routes for input into UNIX-based AFMSS. AFMSS will then be used to perform weapon delivery planning and prepare data transfer devices for loading data into the aircraft.

The next evolution of JMPS will be JMPS Combat One (JC1), which will provide additional functionality to support Navy carrier-based aircraft and replace the Navy's Tactical Automated Mission Planning System (TAMPS) AN/UYQ-81 (V). JC1 adds the ability to plan precision-guided munition (PGM) deliveries and link weapon plans to aircraft routes. It also provides GPS almanac data, weather data, and crypto key support. JC1 will have the capability to produce data transfer devices (i.e., cut cartridges) for carrier aircraft. Although labeled as a joint program, JMPS is actually being managed as a multi-Service program, with each Service following its own procedures. The program does not have a lead Service.

## **BACKGROUND INFORMATION**

The program began in June 1999 with the development of the JMPS framework, which together with addition of government-furnished software will become Version 1.0. Development of JMPS Version 1.0 is proceeding in a series of six Beta releases, each with added functionality and culminating in the full functionality of a basic mission planning system in 2003. In July 2001, the Navy started development of JC1.

OT&E will consist of combined DT/OT, followed by dedicated OT&E periods for each user. The DT/OT activity includes evaluations by the JMPS Test Team of each Beta release and feedback to the developing contractor. JMPS Beta 1 was released in April 2000, Beta 2 was released in July 2000; and Beta 3 was released in February 2001. AFOTEC conducted a formal Operational Assessment (OA) after the September 2001 release of Beta 4, and OPTEVFOR will evaluate Beta 5 in March 2002. Upon delivery and certification of Version 1.0, AFOTEC will conduct IOT&E using Version 1.0 for B-52H route planning. OPTEVFOR will conduct OPEVAL on JC1 in September 2003. Software development problems have led to stretches in the Version 1.0 schedule compared to original plans, and there are risks of further delays.

## **TEST & EVALUATION ACTIVITY**

During FY01, the principal JMPS T&E activity was DT/OT by the Test Team of Beta release number 3. Problems were documented in a government-integrated data base and, following review by a deficiency review board, were transferred to the contractor for resolution. Beta 4 was released in September 2001 and Beta 5 is currently in development.

AFOTEC conducted an Operational Assessment (OA) of JMPS, based on an OA plan approved by OSD in October 2001, following the release of Beta 4 from October – December 2001. Although Beta 4 has limited functionality, analysis of its capabilities will provide insight into the potential effectiveness of JMPS Version 1.0. DOT&E will be briefed on the results of the OA in February 2002.

## **TEST & EVALUATION ASSESSMENT**

JMPS faces many remaining challenges in developing and integrating software components into a system that can be easily used by aircrew and mission planners to plan combat missions, while meeting DoD requirements for security and interoperability. The program is considered to have moderate to high risk of meeting user expectations for overall performance. Additionally, there are risks of further schedule delays to the program due to late delivery of both Logicon (now Northrop Grumman Information Technology (NGIT)) software and government-furnished software components.

OT&E planning for JMPS Version 1.0 and JC1 is still incomplete. The activities and resources needed to integrate UPCs, obtain necessary certifications, conduct training, and prepare initial planning suites for OT&E need to be defined. The JMPS TEMP (or TEMPs) requires updating, and more definitive OT&E test plans must be prepared prior to dedicated IOT&E (now planned for November 2002).

## JOINT STANDOFF WEAPON (JSOW)



The Joint Standoff Weapon (JSOW) is a family of kinematically efficient (~12:1 glide ratio) 1,000-lb class, air-to-surface glide weapons that provide for low observability, standoff precision engagement, and launch and leave capability against a wide range of targets during day/night, all weather conditions. All three JSOW variants employ a tightly coupled Global Positioning System/Inertial Navigation System (GPS/INS). JSOW is employed for interdiction of soft/medium fixed, re-locatable and mobile light and heavy armored targets; massed mobile armored targets; anti-personnel; and air-to-surface threats. JSOW primarily functions in a preplanned mission mode where the system can store up to eight targets; however, the system will allow pilot manual inputs as well as third party targeting as long as the targeting system can meet JSOW's targeting requirements. The weapon will be both land and carrier based.

Mission planning will be accomplished using the Navy's Tactical Automated Mission Planning System (TAMPS) and the Air Force Mission Support System (AFMSS). Integration of operations with the Joint Mission Planning System (JMPS) is planned. JSOW will be employed on the following aircraft: F/A-18C/D and E/F; F-16C/D; F-15E; JSF; B-1B; B-2A; and B-52H. The weapon comes in three operational variants.

- AGM-154A (JSOW Baseline) – USAF and Navy: The payload of the AGM-154A consists of 145 BLU-97/B submunitions. The BLU-97/B is a combined effects munition. The bomblets have a shaped charge for an armor defeat capability, a fragmenting case for material destruction, and a zirconium ring for incendiary effects. JSOW Baseline is designed to conduct pre-planned attacks on stationary soft targets such as: air defense sites, parked aircraft, components of airfields and port facilities, command and control antennas, stationary light vehicles, trucks and artillery, and refinery components.
- AGM-154B – (JSOW BLU-108) - USAF and Navy: The payload for the AGM-154B is the BLU-108 submunition from the Air Force Sensor Fuzed Weapon (SFW). JSOW will carry six BLU-108s, each of which dispenses four warheads or skeets. The skeets carry an infrared or dual mode sensor and, upon detecting a target, detonate to create an explosively formed penetrator that impacts the target. This system is an interdiction weapon with a target set of mixed units of tanks, infantry fighting vehicles/armored personnel carriers, and trucks in a tactical road march formation.
- AGM-154C (Unitary Variant) – Navy only: The AGM-154C, in addition to the common GPS/INS guidance, will use an autonomous imaging infrared seeker for target acquisition

and terminal guidance. The AGM-154C will carry the BAE multiple warhead system (Broach), and is designed to attack point targets such as industrial facilities, logistical systems, and shipping locations.

## **BACKGROUND INFORMATION**

The JSOW program is incorporating a new Low Cost Control Section (LCCS) and Low Cost Guidance Electronics Unit (LCGEU) into all variants. This change is planned prior to final operational test and full-rate production decisions of AGM-154B and AGM-154C variants, but will be cut into the full-rate production of AGM-154A. In addition, JSOW will be integrating the new GPS Selective Availability Anti-Spoofing Module (SAASM) security architecture into the LCGEU for delivery in fielded units in late FY07.

### **AGM-154A, BASELINE VARIANT**

In support of the October 1998 Milestone III decision, DOT&E submitted a combined AGM-154A Operational and Live Fire Test and Evaluation Report to Congress.

In April 2000, material defects were discovered in the payload rails and were identified as safety of flight critical to the BLU-97 payload assembly of the AGM-154A (baseline) variant. The corrective action was implemented and retrofit AGM-154As were released for combat operations.

### **AGM-154B, BLU-108 VARIANT**

Although low rate initial production for the AGM-154B was granted 1QFY99, problems encountered with the LCCS delayed the Multi-Service Operational Test and Evaluation, Milestone III, and Initial Operational Capability. The AGM-154B Milestone III decision is currently planned for 4QFY03.

AGM-154B LFT&E is based upon live fire testing conducted for the SFW program. AGM-154Bs will incorporate the Insensitive Munition (IM) fill with the SFW Preplanned Product Improvement (P<sup>3</sup>I) BLU-108.

### **AGM-154C, UNITARY VARIANT**

The AGM-154C LRIP first delivery is scheduled for 1QFY03. The Milestone III decision is currently planned for 1QFY03. In September 2000, USD(AT&L) approved incorporation of the developmental Broach warhead. Due to incorporation of the new warhead, LFT&E (including system-level realistic lethality testing of the AGM-154C against threat representative targets) is required.

## **TEST & EVALUATION ACTIVITY**

### **AGM-154A, BASELINE VARIANT**

Problems were encountered during developmental testing of full-rate production weapons incorporating the LCCS and LCGEU. An F-18C/D launch attempt in June 2001 had failure indications in the control section similar to the F-16 launch of an AGM-154B in September 2000 in which all control section moveable fins fully deflected just prior to release. The weapon hung on the F-18C/D, due to a

software change designed to prevent release in this situation, unlike the F-16 release in which the weapon went out of control and crashed. Investigation of the cause of fin deflection is now complete. The cause appeared to be the LCCS timing oscillator that would crack during the JSOW launch sequence. Combined DT/OT began in November 2001 and FOT&E is planned following DT/OT to evaluate the proposed solution. The problems delayed integration testing on all platforms.

LCCS Fin Motor BIT fail indications and control fin pin lock and insert wear were observed during F-16 captive carriage. In addition, tracking of GPS satellites was inhibited and resulted in navigation anomalies. A separate investigation into the aerodynamic effects on the LCCS hardware and the GPS tracking algorithms in a low altitude, high Mach environment on weapons carried on the F-16 is underway. Environmental loads and vibration data collection is complete on the F-16, F-18C/D, F/A-18E/F, and the F-15E. Environmental data analysis and navigation anomaly resolution efforts are ongoing in support of the All Up Round (AUR) redesign Engineering Change Proposal (ECP).

#### **AGM-154B, BLU-108 VARIANT**

MOT&E has been delayed due to JSOW common technical issues outlined above. MOT&E will begin after the AUR redesign ECP is incorporated. Current MOT&E planned start is 1QFY03. LFT&E and validation testing for the complete P<sup>3</sup>I BLU-108 submunition is covered in the Sensor Fuzed Weapon section.

#### **AGM-154C, UNITARY VARIANT**

AGM-154C developmental flight testing has begun. An operational assessment is planned for 3QFY02, with initial operational testing starting in 2QFY03.

### **TEST & EVALUATION ASSESSMENT**

#### **AGM-154A, BASELINE VARIANT**

The results of Navy OPEVAL and Air Force IOT&E confirmed that JSOW Baseline, AGM-154A, in the LRIP configuration, is operationally effective and suitable. Initial results of testing of the FRP configuration with the LCCS and LCGEU (reported last year), including side-by-side launch of a AGM-154A with the older control section and an AGM-154A with the LCCS and LCGEU, showed no discernable difference in performance including terminal end-game maneuvering, performance within GPS jamming environments, or weapon accuracy between the two configurations. Further testing uncovered the problems outlined above.

An anomaly in the wind estimator was discovered during operational employment of LRIP weapons. A software change to enhance wind estimator effectiveness is being incorporated and will be evaluated during FOT&E of the full-rate production AGM-154As. The F-16 is currently unable to employ JSOW throughout the entire flight envelope. An AUR engineering change to the weapon is underway and is anticipated to be an 18-month effort. A limited F-16 employment envelope is currently under evaluation. The problems encountered during employment and testing this year raised significant operational concerns that must be resolved and tested.

### **AGM-154B, BLU-108 VARIANT**

Since the AGM-154B uses the same air vehicle as the AGM-154A, some test data will be applicable to both variants. However, dedicated MOT&E of the AGM-154B will not begin until after the AUR engineering change is incorporated. MOT&E weapons will have the BLU-108 P3I warhead with IM fill.

### **AGM-154C, UNITARY VARIANT**

Developmental testing has begun. No operational assessment has been accomplished. Static testing of the Broach warhead and captive carry tests of the seeker have been conducted. The first free flight occurred in December 2001.



## **MH-60R MULTI-MISSION HELICOPTER UPGRADE**



The MH-60R Multi-Mission Helicopter Upgrade originally consisted of a Service Life Extension Program (SLEP) for existing SH-60B, SH-60F, and some HH-60H aircraft. Aircraft remanufacture, avionics improvement, and new or improved mission sensors constituted the program path until cost reconsideration in FY01 resulted in redefinition of the program to include new production aircraft as opposed to remanufactured aircraft. The program develops the AN/AQS-22 Airborne Low Frequency Sonar (ALFS) and increases sonobuoy acoustic signal processing capability. The acoustic suite is designed to improve undersea warfare mission effectiveness against the quiet submarine threat in both deep and shallow water environments. The program also develops the AN/APS-147 Multi-Mode Radar (MMR) that includes Inverse Synthetic Aperture Radar imaging and periscope detection modes of operation. Other improvements include the AN/ALQ-210 electronic support measures (ESM), a fully Integrated Self-Defense (ISD) system, the AN/AAS-44 Forward-Looking Infrared sensor with laser designator, and armament capability to launch Hellfire missiles. The MH-60R and MH-60S helicopters will incorporate the Common Cockpit, which consists of multi-functional displays, keysets, and a complex client-server based tactical data processing system. The program represents a significant avionics modification to the SH-60 series of aircraft by enhancing undersea and surface warfare, surveillance and ID, and power projection.

### **BACKGROUND INFORMATION**

The MH-60R Multi-Mission Helicopter entered EMD in FY93 and combined the missions of the predecessor SH-60B and SH-60F baseline aircraft. A recent program restructure includes new production aircraft instead of remanufactured airframes and was in response to escalating remanufacture costs and the over 12 week late delivery/poor quality of the first four fully remanufactured test articles.

In 1999, a developmental test and an operational assessment were conducted on the AN/AQS-22 ALFS installed in a SH-60B. The tests were primarily focused on the mechanical performance of the system, not the tactical performance. The OA assessed the system to be both potentially operationally effective and suitable. The system exhibited an excessive Built-In-Test (BIT) false alarm rate, an inadequate BIT error reporting format, a below threshold Mean Time Between Mission Critical Failure rate, numerous human factors engineering problems, and insufficient factory training to address the complexity of the system.

In January 1998, DOT&E designated the SH-60R (now redesignated the MH-60R) aircraft a covered system for LFT&E. The waiver granted for the SH-60B/HH-60H Munitions Upgrade Program by the ASN(RDA) Memo of July 1996 has been extended to cover the MH-60R. The DOT&E report to Congress on the Hellfire Missile Integration Program Upgrade to the SH-60B and HH-60H aircraft identified a number of data voids in the original H-60 Live fire data. These voids preclude an adequate evaluation of the MH-60R vulnerability for LFT&E. DOT&E recognized that the data voids were common to all H-60 aircraft variants within the Navy and Army and proposed that the two Services coordinate their efforts and thus minimize cost. In response, a Joint Army/Navy LFT&E Test Program was established to address the data needs of the MH-60R, the MH-60S, and the UH-60M programs. The program takes advantage of the high degree of similarity between components and structure of Navy and Army variants of the H-60. Utilizing the resources and talents of both Services' vulnerability testing establishments, a number of usable H-60 components and structures have been collected, including an operable YCH-60. Testing in this joint program has just begun.

### **TEST & EVALUATION ACTIVITY**

Contractor proof of compliance testing and DT on two YMH-60R prototype aircraft began in January 2000 and continues to the present. The first increment of DT was completed in April 2001 and focused on the performance of the Common Cockpit and on two operating modes of the MMR. The current DT increment additionally focuses on the ESM system, additional operator modes of the MMR, and on the ALFS systems. All testing to date has been performed on the two prototype YMH-60R aircraft due to the late delivery of the first four fully remanufactured test articles.

A four-week DT Assist conducted in February 2001 provided the Operational Test and Evaluation Squadron (VX-1) the opportunity to assess the Common Cockpit and two modes of the MMR. Although a DT Assist, by definition, does not provide sufficient operational test opportunity to resolve Critical Operational Issues, it did provide operational exposure to the system and early operational feedback to the Program Manager, especially in the area of man-machine interface issues.

The program has incurred several breaches of the Acquisition Program Baseline schedule and cost, reflected by subsequent instances of program restructure. The January 1994 Test and Evaluation Master Plan (TEMP) and the March 1992 Operational Requirements Document (ORD) are being updated to reflect the latest program restructure. The ORD revision is undergoing Joint review. The TEMP revision will reflect the updated ORD.

The first tests under the Joint Army/Navy LFT&E test program included static flight control shots executed by the Army at Aberdeen Proving Ground in June 2001. These tests provided order of magnitude threat effect data to allow threat selection for dynamic flight controls tests to be accomplished at the Naval Air Warfare Center – Weapons Division, China Lake in September 2001. This program differs from the extensive prior testing of the H-60 in that a large number of the tests will be conducted under dynamic conditions while the aircraft is in a 1G-hover condition. There is some risk under these conditions, that the single operable test aircraft will be destroyed prematurely.

### **TEST & EVALUATION ASSESSMENT**

The Common Cockpit and the MMR demonstrated low levels of hardware and software maturity throughout FY00 contractor proof of compliance testing and DT. A major restructure of the Lockheed

Martin team in 2001 and the new Navy Program Manager's insistence that the Common Cockpit system be baseline tested and that configuration control discipline be imposed have proven successful. The system is now beginning to exhibit stable, more mature performance.

The paucity of spare component parts has adversely impacted the program. Design problems in the MMR traveling wave tube amplifier (TWTA) have limited Telephonics and the Navy to two workable systems for contractor proof of compliance testing and DT while Telephonics seeks a second TWTA source. Numerous failures of the Common Cockpit multi-functional displays adversely impacted testing of both the MH-60R and MH-60S aircraft.

Test data acquired from the Joint Live Fire test program funded by DOT&E have contributed to assessing the vulnerability of the aircraft. Though off to a good start with the static flight control tests at Aberdeen, program success depends greatly on a single operable YCH-60 ground test vehicle. If any of the tests destroy the vehicle prematurely this program could be faced with either funding a new test article or terminating with insufficient data.

This Page Is Intentionally Left Blank

## **MH-60S FLEET COMBAT SUPPORT HELICOPTER**



The MH-60S Fleet Combat Support Helicopter is the replacement for the current Navy CH-46D, which is nearing or exceeding its original service life. The MH-60S is designed to provide the Navy's Combat Logistic Force with: (1) responsive vertical replenishment (VERTREP); (2) vertical onboard delivery; (3) airhead support; and (4) day/night Amphibious Task Force search and rescue (SAR) services. Secondary missions include Special Warfare (over water) Support, aero medical evacuation, and noncombatant evacuation. A second mission configuration of the MH-60S is being designed to support: (1) Combat Search and Rescue/Special Warfare (over land) Support (CSAR/SWS); (2) Anti Surface Warfare; and (3) Aircraft Carrier Plane Guard/SAR. A third mission configuration was approved in May 2000 to support the Airborne Mine Countermeasures (AMCM) mission.

The MH-60S is an Army UH-60L Black Hawk airframe incorporating Navy Seahawk marinized GE T-700 engines, folding rotor head and tail pylon, transmission/drive train, stabilator, and flight controls. The MH-60S shares with the Navy MH-60R helicopter a Common Cockpit, which consists of multi-functional displays, key sets, and a complex client-server based tactical data processing system. The MH-60S avionics will include: (1) dual UHF/VHF transceivers; (2) inertial and Global Positioning System navigation; (3) night vision device-compatible heads-up displays; and (4) a ground proximity warning system. The aircraft will have provisions installed to incorporate a future CSAR mission kit consisting of tactical moving maps, Forward-Looking Infrared sensor with a laser range finder/designator, crew-served side suppression weapons, Hellfire missiles, forward firing guns/rockets, and an integrated self-defense system. The aircraft will also have provisions installed to incorporate AMCM sensors and destructors, individual programs that are currently in development.

### **BACKGROUND INFORMATION**

Contractor flight tests commenced in January 2000 and continued into May. Late delivery of the aircraft from Sikorsky, technical problems with the Common Cockpit, and immature Lockheed Martin software prompted the Navy to restructure the program in October 2000. The restructured program provided an additional 185-flight hours to test the Common Cockpit, testing originally planned for the MH-60R program. The MH-60R program had incurred excessive schedule delays and could no longer support the original plan.

DOT&E designated the MH-60S as a covered system under Live Fire Test. An alternative LFT&E plan was approved in 1998 and a waiver from full-up, system-level testing was granted.

Congress was notified. The initial LFT&E strategy for the MH-60S (Vertical Replenishment version) required assessment of its combat survivability and potential for crew casualties. The strategy required that a recommendation be made for any necessary additional tests pertinent to the threats encountered in the CSAR and the AMCM missions. A panel of Navy, Army, and OSD experts convened in March 1999 and concluded that important data voids existed. DOT&E recognized that the data voids were common to all H-60 aircraft variants within the Navy and Army and proposed that the two Services coordinate their efforts and thus minimize cost. In response, a Joint Army/Navy LFT&E Test Program was established to address the data needs of the MH-60R, the MH-60S, and the UH-60M programs. The program takes advantage of the high degree of similarity between components and structure of Navy and Army variants of the H-60. Utilizing the resources and talents of both Services' vulnerability testing establishments, a number of usable H-60 components and structures have been collected including an operable YCH-60. The Services prepared an H-60 family LFT&E plan and initiated testing in 2001.

### **TEST & EVALUATION ACTIVITY**

TECHEVAL commenced mid-May 2000 and was scheduled for completion in January 2001. Testing was hampered by immature hardware and software. DT was extended through the mid-July 2001 timeframe to certify the Common Cockpit for instrument meteorological conditions (IMC). Improper Tactical Air Navigation antenna switching and interference in the VHF Omni-directional Range/Instrument Landing System delayed successful IMC clearance certification until September 2001. The scheduled commencement of OPEVAL in August 2001 was delayed by IMC certification, as well as out-of-specification aircraft vibration and receipt of the DT/OT transition report. DOT&E approved the test plan for OPEVAL, which commenced in October 2001.

The May 2000 Operational Requirements Document Revision is being updated to include Joint Interoperability as a Key Performance Parameter and changes VERTREP endurance and Common Cockpit BIT parameters. The TEMP revision incorporating the AMCM mission will also reflect changes in the updated ORD revision. The TEMP is targeted for approval before Milestone III for the Fleet Combat Support Helicopter missions scheduled in June 2002.

The first tests under the Joint Army/Navy LFT&E test program included static flight control shots executed by the Army at Aberdeen Proving Ground in June 2001. These tests provided order of magnitude threat effect data to allow threat selection for dynamic flight controls tests to be accomplished at Naval Air Warfare Center – Weapons Division, China Lake in September 2001. This program differs from the extensive prior testing of the H-60 in that a large number of the tests will be conducted under dynamic conditions while the aircraft is in a 1G-hover condition. There is some risk, under these conditions, that the single operable test aircraft will be destroyed prematurely.

### **TEST & EVALUATION ASSESSMENT**

Both contractor and DT testing demonstrated poor maturity and stability levels for the Common Cockpit system and the numerous navigation/communication systems that interface with it. This directly contributed to schedule delays by forcing the program into a test-fix-test evolution throughout the test period. A major restructure of the Lockheed Martin team and the insistence of the new Navy program manager to establish a tested baseline through imposition of strict configuration control of both software and hardware proved to be successful by June 2001. However, insufficient provisioning of spare

component parts for the Common Cockpit and delay in certifying the aircraft for instrument flight contributed to additional schedule delays.

The rapid development of the Common Cockpit system for installation in both the MH-60S and MH-60R proved to be a large technical challenge, even though it was based on contractor-off-the-shelf and government-off-the-shelf components. Development of a digitized glass cockpit is a complex task that demands strict configuration control measures be in place for timely, successful completion. Additional complexity will occur as AMCM and CSAR mission avionics and weapons are integrated into the Common Cockpit system in the future and the technical challenge should not be underestimated.

The out-of-specification aircraft vibration noted during DT just prior to OPEVAL was not anticipated. Although the Navy propulsion system had not been paired with the Black Hawk airframe before, the similarity of the Army propulsion system alleviated any excess vibration concerns during early development. The MH-60S out-of-specification vibration levels could not be dampened by adjustment of the cabin absorbers nor the existing centrifugal weights (bi-filers) at the main rotor. Because thousands of Black Hawk and Sea Hawk aircraft have been built, neither Sikorsky nor the Navy anticipated vibration problems of this magnitude. A prototype fix for the out-of-specification vibration levels is undergoing contractor testing and is showing promising results. A production version is scheduled to be installed and operationally tested prior to IOC of the aircraft.

Test data acquired from the Joint Live Fire test program funded by DOT&E have contributed to assessing the vulnerability of the aircraft. Though off to a good start with the static flight control tests at Aberdeen, the program depends greatly on a single operable YCH-60 ground test vehicle. If any of the tests destroy the vehicle prematurely, this program could be faced with either funding a new test article or terminating with insufficient data.

This Page Is Intentionally Left Blank



## MISSILE AND LASER WARNING SYSTEM, AN/AAR-47(V)2

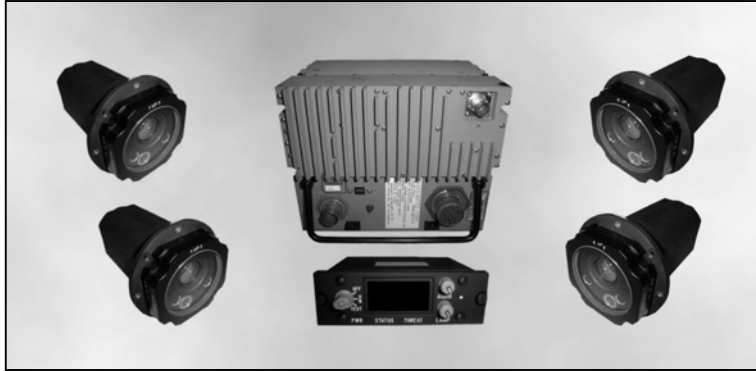

The AN/AAR-47, originally fielded in the late 1980s, provides passive warning against infrared and laser guided missiles fired at its host platform. In addition to providing warning to the aircrew, it cues an onboard expendables dispenser to eject countermeasures flares to defeat the incoming missile. The system consists of four sensor units oriented about the aircraft to provide 360-degree protection; a processor that analyzes the signals received by the sensors declares an incoming threat, warns the aircrew, and initiates dispensing of flares; and a control/indicator unit provides warning indications to the aircrew and allows control of the system (in some aircraft installations control and indication are integrated into the APR-39 radar warning receiver controls and displays).

The AAR-47(V)2 upgrade provides improved sensors that eliminate sensor blackening, a known failure mode; increases temperature tolerance and provides a more uniform sensitivity; and provides a new filter to improve false alarm control. Additionally, the new sensor has a laser detector that allows the AAR-47(V)2 to provide the functionality of the AVR-2/2A laser warning systems. This added functionality will allow the Navy to retire the AVR2/2A at a considerable cost saving and provide laser warning for aircraft that did not have the AVR2/2A installed. New software, version 22.21, provides increased probability of missile detection and reduced false alarm rate, provides for laser threat correlation and classification, and revises the interface with the APR-39 to provide laser warning information. A new control/indicator that incorporates the laser warning capability is also provided for aircraft without an APR-39.

### **BACKGROUND INFORMATION**

There are roughly 2,500 AAR-47 systems worldwide. Approximately 2,000 belong to DoD; of those, around 1,200 belong to the Navy. The Navy has 254 AVR-2s and 42 AVR-2A systems. Navy aircraft that currently have or are planned to have AAR-47 capability are: H-1 variants, H-3 Type, Model, Series (TMS), CH-46E, H-53 TMS, H-60 TMS, V-22, P-3C, and C-130 TMS. Navy aircraft equipped with AVR-2s are the UH-1N, AH-1W, VH-3, and VH-60. HH-60H aircraft are equipped with the AVR-2A. The Navy's intent is to eventually replace all AAR-47s and AVR-2/2As with the AAR-47(V)2. The Army and Air Force, who have the remainder of the DoD AAR-47s, are not currently planning to upgrade to the AAR-47(V)2.

## **TEST & EVALUATION ACTIVITY**

DT/OT of the missile warning and laser warning capabilities was conducted during FY01. Test events included live missile shots at the Aerial Cable Facility (ACF) at White Sands Missile Range, laser warning flight tests at both White Sands and the Naval Air Warfare Center at Patuxent River, Maryland, and false alarm testing at several locations. The ACF tests used a UH-1 hulk as the test platform and all flight tests were conducted on a UH-1N. The upgraded missile warning functions with software version 22.21 were tested against a baseline system with software version 20.0. The laser warning functions were compared against the performance of the current AVR-2A. The baseline AAR-47 and/or the AVR-2A were installed in the test vehicle, along with the AAR-47(V)2 as appropriate for the test being conducted.

## **TEST & EVALUATION ASSESSMENT**

During DT/OT, the AAR-47(V)2 demonstrated satisfactory performance in all aspects of the missile warning function. Using the version 22.21 software, it detected all 12 missiles of various types fired at it during the live fire tests. The false alarm rate was considerably reduced compared to the version 20.0 baseline software.

The laser warning function performed satisfactorily against one class of threat but unsatisfactorily against another. The unsatisfactory performance was against a threat simulator of questionable validity. A higher fidelity simulator has become available since the completion of the DT/OT. Tests should be conducted against this simulator in later test phases to determine if performance against this class of threat is truly deficient. The laser warning false alarm rate was acceptably low.

Many of the suitability measures of effectiveness await resolution in the remaining dedicated OT phase of testing. The system has demonstrated good reliability to date and only one built-in test false alarm was noted in 81.5 hours of operation.

## MK 48 ADCAP TORPEDO UPGRADES



The Mk 48 ADCAP torpedo is a submarine launched, heavyweight acoustic homing torpedo. It includes all digital guidance and control (G&C) systems, digital fuzing systems, and an advanced propulsion system for improved speed, depth, and range capability. For the submarine force, the Mk 48-class torpedoes are the only weapons currently carried for attacks on enemy submarines and surface ships.

The Fleet baseline ADCAP is designated the Mk 48 Mod 5. A 1995 upgrade, designated Mk 48 Mod 6, features an improved G&C section and a Torpedo Propulsion Upgrade (TPU). Development of a follow-on hardware change to the Mod 6 ADCAP, called the Advanced Common Torpedo Development Vehicle (ACOT-DV), has been delayed for several years. It will be incorporated into the next-generation torpedo, the Common Broadband Advanced Sonar System (CBASS), planned for FY05.

Three software builds are currently under oversight. Block Upgrade III is the final tactical software upgrade to the Mod 5. Block IV was designed to extend Block III capabilities and apply them to the Mod 6 weapon. The more sophisticated CBASS software is planned to follow Block IV. In lieu of future Block Upgrades, the program plans to employ a series of Advanced Processor Builds (APBs), to both the Mod 6 and Mod 7 weapons, as a more flexible means of introducing software changes. More information on the hardware and software improvements are contained in the classified report.

### **BACKGROUND INFORMATION**

The Mod 5 ADCAP torpedo OPEVAL and B-LRIP report were completed in 1988, with FOT&E in 1991 on Software Block Upgrade I. In 1994, Block Upgrade II was introduced to improve performance. DOT&E assessed ADCAP to be operationally effective following this improvement, but some areas remained unsatisfactory. OPEVAL of Block III was completed in FY97.

The Mod 6 ADCAP, intended to address open issues from previous OT&E, was tested in 1995 and reported in the 1996 B-LRIP report. DOT&E assessed the Mod 6 ADCAP to be both operationally effective and suitable. Although the reliability was marginally below threshold, DOT&E identified the Mod 6 ADCAP as producing a total performance much better against the expected threat than the Mod 5 ADCAP.

Developmental testing for Block IV was completed at Cape Cod in October 1998.

## **TEST & EVALUATION ACTIVITY**

In FY01, the Navy maintained a robust schedule of other ADCAP torpedo exercises. These included four Prospective Commanding Officer exercises, one of which was conducted jointly with the Royal Australian Navy. Another forward-area torpedo exercise provided valuable data from an actual threat environment. Also, OPEVAL of Block IV software was completed in early FY01.

## **TEST & EVALUATION ASSESSMENT**

The results of the Block IV testing are commented on in the classified version of this report.

Since safety considerations preclude actual target intercepts during exercise firings, warshot performance must be assessed separately. In recent combined-arms SINKEXs, naval surface and air units have destroyed the target before the submarine had a chance to fire a torpedo. Since the surface and air attacks, while good training, are of limited operational value and given the limited availability of hulk targets, warshot torpedo firings should be given a higher priority during SINKEXs.

Torpedo reliability, as described in previous Annual Reports, remains a concern. These failures highlight the overall problem of ADCAP reliability, which continues to run in cycles. In addition to the issues discussed above, work force reductions at the weapon's depots may also threaten the fleet's ability to process weapons quickly and accurately.

## **LESSONS LEARNED**

As cited in previous reports, some performance questions remain unresolved due to inadequate T&E resources and funding. For open-ocean shallow water exercises, the tested torpedo's internal monitoring equipment is the only source of data, resulting in post-run analysis biases and errors. DOT&E believes that development of an inexpensive mobile test range, or other independent instrumentation, is necessary to alleviate shallow water testing shortfalls. As a more permanent solution, DOT&E believes that, given the high priority of the diesel submarine threat, an instrumented shallow water test range would help hasten maturation of littoral ASW tactics and improvement in shallow water ASW torpedoes. The cumbersome nature of open ocean torpedo firings, coupled with seasonal marine mammal habitat restrictions at Cape Cod, has significantly lengthened development cycle times. Congressional funding support for a viable instrumented shallow water test range is strongly recommended.

Additional emphasis should be placed on warshot firings to verify the weapon's ability to hit and sink both surface and subsurface targets.

DOT&E supports the flexibility of the APB approach, but will continue to insist upon complete and rigorous testing of all upgrades.

Side-by-side test and evaluation of ADCAP software variants, although on the surface more expensive, might be more cost-effective in the larger scheme because less time might be lost if side-by-side test and evaluation are performed. Right now, disagreements between operational testers and developers are attributable to results taken in arguably different and difficult-to-reconcile environmental and tactical conditions. Side-by-side testing would narrow that gulf. Thus, DOT&E again recommends that future ADCAP test and evaluation be done in a side-by-side manner.

# MULTIFUNCTIONAL INFORMATION DISTRIBUTION SYSTEM-LOW VOLUME TERMINAL 1 (MIDS-LVT 1)



The MIDS-LVT 1 provides Link 16 digital data communications to fighter, surface combatant, and Command and Control (C2) host systems. The MIDS System includes the MIDS-LVT 1 terminal, remote power supply, host platform software, antenna, and displays. The terminal consists of Shop-Replaceable Unit (SRU) components that can be replaced or removed depending on host platform needs. For surface ship applications, the 200-watt MIDS-LVT 1 Power Amplifier is augmented with a 1,000-watt High Power Amplifier. For fighter aircraft, due to space constraints, the existing stand-alone Tactical Air Navigation (TACAN) is removed and replaced with a TACAN SRU to provide the navigation function and space for the MIDS-LVT 1. Planned U.S. MIDS-LVT 1 host platforms include ships, F/A-18, F-16, EA-6B, and B-2.

## **BACKGROUND INFORMATION**

In April 2000, OSD approved the Lot 1 Low Rate Initial Production (LRIP) of MIDS-LVT terminals. The LRIP terminals will be used for host platform integration, test, and early fielding. A second LRIP Lot was approved during 4QFY01 and a third is planned for FY02. The MIDS-LVT full-rate production decision is scheduled for 4QFY03, concurrent with the fielding decision for the MIDS-LVT 1 on F/A-18 fighter aircraft. Other MIDS-LVT platforms will have separate fielding decisions from FY03 forward after appropriate initial operational test and evaluation (IOT&E). All tests conducted during FY01 were conducted with the MIDS Consortium Engineering Manufacturing Development MIDS-LVT terminal. Evaluation of the production-representative LRIP MIDS-LVT terminals is planned for FY02.

## **TEST & EVALUATION ACTIVITY**

During FY01, the Navy conducted a MIDS-LVT on Ship (MOS) integration Operational Assessment (OA) in a hardware-in-the-loop laboratory. The objective of the test was to assess readiness for installation of MOS into ships.

Commander, Operational Test and Evaluation Force (COMOPTEVFOR) completed an F/A-18 MIDS-LVT integration OA during FY01. The objectives of this test were to determine whether the critical deficiencies identified during FY00 had been resolved and to provide Lot 2 LRIP decision

support. The test included operation in a Link 16 network during a Large Force Exercise (LFE) with participating ships, the USAF's E-3 Airborne Warning and Control System (AWACS) and F-15 fighter aircraft.

The first DT flights of an F-16 aircraft modified with MIDS-LVT were completed during FY01. The F-16 MIDS-LVT integration OT event, an OA, will begin in 1QFY02 and continue through development.

## **TEST & EVALUATION ASSESSMENT**

The MOS is rated as potentially operationally effective and potentially operationally suitable. However, reliability, maintainability, training, and human factors deficiencies remain. As a result of a program restructure, the MOS OT test event (IOT&E) will not occur until 4QFY03. There will be a DT Assist in 2QFY03; however, this may not provide adequate data to assess the risk to a successful IOT&E.

During the F/A-18 MIDS-LVT OA conducted in FY01, five of the major areas of risk identified during FY00 were assessed as uncorrected. In addition, another eight Major Areas of Risk were identified. DOT&E considers Mission Computer failures, TACAN performance, Multi-Sensor Integration, position errors, and cockpit workload issues as critical deficiencies. In the OA, the F/A-18 MIDS integration was assessed as potentially not operationally effective and not operationally suitable. During FY01, the MIDS-LVT-equipped F/A-18 participated in LFEs and training events with other Link 16 capable platforms. These included ships, the E-2C Hawkeye, the F-14 fighter, the E-3 AWACS, and F-15 fighters. Although a number of interoperability deficiencies were identified, the F/A-18 MIDS-LVT was able to enter and operate in Link 16 networks with these platforms and exchange meaningful information that increased overall situation awareness. False or inaccurate fighter engagement lines and sensor source information on targets were critical interoperability deficiencies and stemmed from varying host platform implementations of Link 16 messages.

Link 16 joint interoperability is ensured by adherence to the common Link 16 waveform, standard message sets, and Link 16 network designs. The tests indicated that incorrect host platform implementation of Link 16 messages resulted in loss of mission functionality in other Link 16 platforms. DOT&E will continue to stress Link 16 interoperability certification before entry into IOT&E for all MIDS host platforms. This certification will be followed by live test events that will be conducted with a mission focus in robust, operational environments.

## **LESSONS LEARNED**

The operational test strategy is based on the evaluation of MIDS-LVT as integrated into the host platform as by itself the terminal provides no combat capability. Experience from tests of the Joint Tactical Information Distribution System Class 2 terminals suggests that integration of the terminal into the host platform is a critical challenge that must be met in order to provide combat capability.

## NAVY EXTREMELY HIGH FREQUENCY SATELLITE COMMUNICATIONS PROGRAM (NESP)

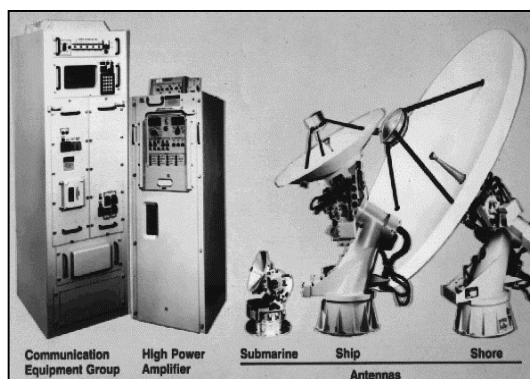

The Navy Extremely High Frequency (EHF) Satellite Communications Program (NESP) terminal connects ship, shore, and submarine platforms to the MILSTAR satellite constellation. The NESP terminal supports survivable, enduring, and flexible worldwide command and control communications to strategic and tactical Naval forces through all levels of conflict. The NESP terminal provides minimum essential secure communications in stressed environments that require anti-jam and low-probability-of-intercept capabilities.

There are three different configurations of the NESP terminal corresponding to ship, shore, and submarine platforms. Although each terminal has the same basic capabilities, their antennas and other peripheral equipment vary by platform. The NESP terminal is being upgraded to add a tactical medium data rate (MDR) capability to the existing strategic low data rate (LDR) capability. A limited number (64) of the existing NESP ship and shore terminals are being upgraded with an MDR appliqué to achieve the combined low/medium data rate MILSTAR capability. The submarine LDR terminals are undergoing MDR upgrades, including modification for a new mast and 16" antenna, as well as addition of the super high frequency and Global Broadcast Service capabilities.

The Navy is developing two new communications controllers, the Navy EHF Communications Controller (NECC) and the Time Division Multiple Access (TDMA) Interface Processor (TIP). The NECC and TIP are baseband interface units that allow more efficient use of MILSTAR satellite resources. The NECC supports LDR networks, while the TIP supports MDR networks.

### **BACKGROUND INFORMATION**

The NESP low data rate terminal reached full production status in 1993. IOT&E for the low data rate terminal included three operational tests that supported MILSTAR Milestone IIIA and IIIB decisions. Since the NESP IOT&E occurred before the first MILSTAR satellite was on orbit, Navy UHF Follow-On satellites with EHF payloads supported the three IOT&E events.

Two follow-on operational tests were conducted after the first MILSTAR satellite was in orbit. The first verified the NESP terminal operated with an in-orbit MILSTAR satellite. It also addressed unresolved issues and deficiencies observed in prior tests, while the second addressed LDR anti-jam and low probability of intercept performance.

## **TEST & EVALUATION ACTIVITY**

Testing of the NESP MDR terminal began with the successful launch of MILSTAR Flight 4 on February 27, 2001, with DT/OT events occurring from March-July 2001. NESP terminals participated in a MILSTAR system test, which demonstrated compatibility and interoperability with the low and medium data rate payloads in orbit. Tests included satellite acquisition, simultaneous network operations, interoperable network and point-to-point calls with Army, Navy, and Air Force terminals, and antenna and network control functions.

Anti-jam and low probability of intercept are two important characteristics of the NESP MDR terminal and MDR OT&E will employ modeling and simulation, rather than testing, to evaluate the terminal's ability to meet requirements. Model validation testing of both the anti-jam and low probability of intercept models was conducted in 2001 and analysis of the test results is pending.

The NESP terminal with the NECC participated in a Navy developmental test in FY01. OT&E of the NESP terminal with the NECC was planned for September 2001, but was subsequently delayed. This test will use on-shore and at-sea terminals to determine operational effectiveness and suitability.

The MDR OT&E for the NESP terminal with the MDR appliqué is planned for FY02. The test will be conducted using on-shore and at-sea terminals, and will include Army terminals to demonstrate Service terminal interoperability. Follow-on tests will be conducted to address the TIP (still under development) and any other issues not fully resolved during this test.

The submarine MDR terminal operational test schedule will be integrated into the overall MILSTAR and NESP terminal test schedules to the greatest extent possible, consistent with submarine terminal progress. Current plans are to conduct submarine terminal testing jointly during operational testing of the NESP ship and shore terminals. Operational test of the NESP Follow-On Terminals is scheduled to begin 3-4QFY02.

## **TEST & EVALUATION ASSESSMENT**

At the completion of the LDR IOT&E, DOT&E concluded that the ship and shore NESP terminals were operationally effective and suitable. These findings supported full fleet introduction. COMOPTEVFOR and DOT&E recommended a follow-on operational test to evaluate the suitability of the submarine terminal and the survivability of the ship and submarine terminals.

Although the MILSTAR LDR submarine terminal does meet the technical and operational requirements for low probability of intercept (LPI), operational tests showed that the submarine had a substantially higher probability of signal intercept than developmental tests had indicated. These LPI results reinforce the role of operational testing in providing the warfighter with the most accurate operational performance information possible.

No assessment can be made regarding operational effectiveness and suitability of the MDR-capable NESP terminals since operational testing has not yet been conducted. The NESP TEMP was approved by DOT&E in FY01. Associated test plans are being updated for DOT&E approval in anticipation of MDR testing with MILSTAR Flight 4 in FY02.



## NAVY MARINE CORPS INTRANET (NMCI)



The Navy Marine Corps Intranet (NMCI) is an information technology (IT) services contract to provide reliable, secure, and seamless information services to the shore-based components of the Navy and Marine Corps. NMCI infrastructure and services will not extend to afloat or deployed units. It is required to support new processes and enable new initiatives such as knowledge management, distance learning, and telemedicine to improve the quality of life for Department of the Navy employees and support personnel. NMCI will provide IT services using a seat management contract that delivers comprehensive information services through a common computing and communications environment. Upgrades, modernization, and technology refreshment will occur over the NMCI contract life-cycle.

The architecture will support Navy and Marine Corps bases, camps, stations, and activities in the Continental U.S., Alaska, Hawaii, Puerto Rico, and Guantanamo Bay, Cuba, for an estimated 411,000 seats. The NMCI is not intended nor designed to provide direct support to Navy units afloat or deployed—they are supported by the Defense Information System Network. However the NMCI will connect with and provide network access service to Navy ships docked in the NMCI-supported areas. It is currently anticipated that in order to meet the Service Level Agreements and provide service for the estimated user base, a total of 72 server farms, six Network Operations Centers and 2 Help Desk Centers will be required.

### **BACKGROUND INFORMATION**

The NMCI initiative differs from a traditional DoD acquisition program, where typically a system is purchased and the government assumes configuration control and life-cycle maintenance responsibility. The NMCI contract is for the procurement of IT services (not systems) based on a commercial model of service level agreements. Under this model, the emphasis is placed on the verification, validation, and monitoring of the end-user services and not on the underlying infrastructure or systems.

Due to the large scale and complexity of the NMCI initiative, implementation will take several years to reach full operating capability.

## **TEST & EVALUATION ACTIVITY**

The contractor, in conjunction with Commander, Operational Test and Evaluation Force (COMOPTEVFOR), conducted a Baseline System Assessment in 2QFY01 on the existing IT configuration, including hardware, software, security and current performance levels at four Naval aviation sites. This data collection consisted of three qualitative surveys and a series of quantitative measurements. Although this is not strictly a test, the data collected will be referenced to measure improvements provided by NMCI.

The current test strategy for NMCI calls for a sequence of contractor test and evaluation (CT&E) events conducted by an agent of the contractor, followed by an OPEVAL. The developmental testing will evaluate the technical performance of the NMCI infrastructure at the component (phase 1), system (phase 2), and mission relation (phase 3) levels. At the conclusion of the third phase of the CT&E, an independent review team will perform an independent evaluation of the contractor test results.

Following the successful conclusion of contractor testing, an OPEVAL will be conducted by COMOPTEVFOR during 3QFY02 to assess the operational effectiveness and operational suitability of NMCI at five test sites: Naval Air Facility Washington, DC (NAFW); Naval Air Systems Command Headquarters, Patuxent River, MD (PAX); Naval Air Station (NAS) Lemoore, CA; Naval Reserve Center (NRC) Lemoore, CA, and an aircraft carrier yet to be determined.

## **TEST & EVALUATION ASSESSMENT**

The planned CT&E has experienced significant delays against the very optimistic and aggressive schedule. All three phases of CT&E were scheduled to be completed in CY01, but major difficulties were encountered during the initial software installation. A centralized distribution center is established for installing and upgrading workstation software. Unfortunately, during early site setup it was found that the site chosen for the distribution center was not well connected to the test sites over the early skeletal network. This caused significant delays in populating the test site workstations with system and application software. The second phase of CT&E slipped at least 6 weeks at NAFW, PAX, NAS Lemoore and NRC Lemoore, and the third and final phase of CT&E will not be completed and reported until mid-February 2002. The schedule impact upon the OPEVAL, which is currently planned for 3QFY02, is yet to be determined.

## NAVY STANDARD INTEGRATED PERSONNEL SYSTEM (NSIPS)

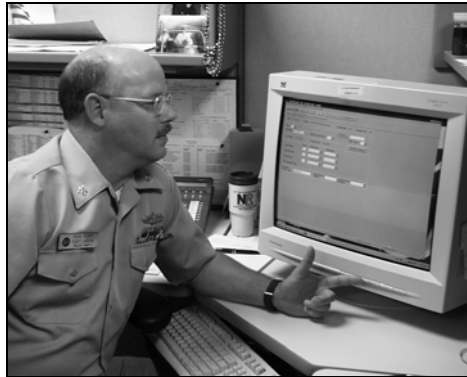

The Navy Standard Integrated Personnel System (NSIPS) will consolidate the Navy active and reserve field source personnel data collection systems, both ashore and afloat. The objective is to produce a standard, single point of entry system for all personnel and pay information. The primary interfaces for NSIPS will be with systems of the Defense Finance and Accounting Service (DFAS). NSIPS provides pay and personnel functionality for the Navy reserve force in Release 0 and for the Navy active force in Release 1. The client-server architecture will have information stored at the local level and at the regional level. A corporate-level data base will be used for planning and analysis purposes.

### **BACKGROUND INFORMATION**

In 1997, the PM developed a prototype system to prove out the planned architecture and “user friendliness” of the graphical user interface. *PeopleSoft*® was selected as the basic human resource software package. This package was customized and the Navy requirements were incorporated in Release 0 to address the Navy reserve requirements. The Release 0 OPEVAL began in mid-September 1999. Many deficiencies were noted, including inaccurate transmittal logs, missing e-mail functionality, corrupted reports, and inadequate training. The PM immediately developed a plan of actions to address these shortcomings. Beginning in October 1999, three separate software builds were installed to fix the problems and OPEVAL resumed in November 1999. In January 2000, DOT&E concurred with COMOPTEVFOR’s conclusion that NSIPS Release 0 is operationally effective and operationally suitable and recommended approval for fleet introduction. NSIPS Release 0, which replaced the Reserve Standard Training, Administration, and Readiness Support (Manpower and Personnel) System, is currently operational at 260 reserve sites.

In June 2000, the PM announced a four-month schedule slip in software development and proposed that Release 1 be delivered in two separate increments. The first increment (Release 0.2) would address personnel actions and the second increment (Release 1) would address pay actions for the Navy active force. Each increment would undergo a full operational evaluation.

## **TEST & EVALUATION ACTIVITY**

Operational evaluation of Release 0.2 was conducted during the period April 23 to May 4, 2001. Operational evaluation of Release 1 is scheduled for February 2002, with a fielding decision expected in May 2002. Full operational capability is planned for July 2002.

## **TEST & EVALUATION ASSESSMENT**

The OPEVAL results of Release 0.2 indicated that two effectiveness and eight (of ten) suitability critical operational issues were resolved satisfactorily. Interoperability and documentation were found unsatisfactory. Corrections were subsequently made and a follow-on test was conducted from July 9-27, 2001. Test results of the follow-on evaluation indicated that previously identified deficiencies had been corrected.

## RADAR WARNING RECEIVER (RWR) AN/APR-39A (V)2

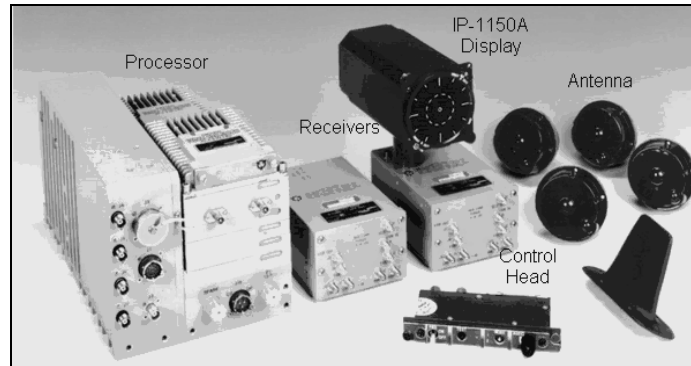

The APR-39A (V)2 Radar Warning Receiver (RWR) improves individual aircraft survival through improved aircrew situational awareness of the electromagnetic threat environment. The APR-39A (V)2 is a multi-Service (Navy/USMC, and Special Operations Force) next generation RWR upgrade to the existing APR-39 (V1). The upgraded system is intended for helicopters and other non-high performance aircraft. It is capable of detecting and providing alerts to the aircrew of surface to air missile (SAM) and antiaircraft artillery associated pulse, pulse Doppler, and continuous wave radar activities identified from a software programmable threat library. In addition to the cockpit video display, the APR-39A (V)2 provides the aircrew with synthetic speech audio threat warnings, facilitating a "hands on/heads up" aircrew posture. The system also integrates with other elements of the aircraft survivability equipment suite and, depending on aircraft configuration, provides control and display functions for the AVR-2/2A laser warning system family, the AAR-47 missile warning system, and the ALE-39 or ALE-47 countermeasures dispenser. The system retains the former APR-39A (V)1 low band vertically polarized blade antenna. The new, more sensitive, circularly polarized spiral antennas are a form and fit replacement for the previous equipment, as is the new night vision compatible cockpit video display and the cockpit control unit.

### **BACKGROUND INFORMATION**

Early Navy operational testing in the USMC AH-1W helicopter, from FY91-92, found the system not operationally effective and potentially operationally suitable. Fleet introduction was not recommended until a subsequent OPEVAL could demonstrate satisfactory resolution of OT-IIA deficiencies.

OT-IIB in a USMC UH-1N helicopter (in accordance with a DOT&E-approved TEMP and test plan) was completed by COMOPTEVFOR in May 1995, with a finding of operationally effective and suitable and a recommendation for fleet introduction into UH-1N. Involvement by the Operational Test community in the DT leading to this phase of OT facilitated meaningful use of DT test results and allowed some streamlining of OT-IIB.

Since the APR-39A (V)2 RWR is not a major defense acquisition program, no B-LRIP report was produced. The system is covered by language in the National Defense Authorization Act for Fiscal Year 1989, Conference Report (H.R. 4481, page 345) which "directed that all future operational test

results for RWR update programs be reviewed and approved by the Director of Operational Test and Evaluation, prior to obligation of production funds."

The Navy Milestone III was approved in 1QFY96. APR-39A (V)2 systems are intended as the standard RWR for the UH-1N, AH-1, V-22, VH-60, HH-60, SH-60, CH-53, MH-53, KC-130, and the VH-3 aircraft. Follow-on Operational Test and Evaluations (FOT&Es) of the HH-60 and AH-1W were conducted during FY01 according to DOT&E approved test plans and results are being analyzed.

### **TEST & EVALUATION ACTIVITY**

The first production units marked for testing were delivered in 3QFY99 and installed on the AH-1W, the lead FOT&E platform. The AH-1W APR-39A(V)2 Electronic Warfare suite and associated operating software were delivered to the government for independent validation and verification testing as part of host platform integration test efforts. Developmental flight testing on AH-1W and the HH-60H were completed in FY00. The FOT&E on these platforms was completed in FY01 and the results are being analyzed.

The APR-39A(V)2, as integrated on the MV-22, was delivered to the government as Contractor Furnished Equipment. The Electronic Warfare suite, as installed and integrated, was tested as part of the MV-22 complete airframe IOT&E in July 2000. Within the limited scope of these tests, the APR-39A (V)2 was effective and suitable. Plans to conduct FOTE in the HH-53 are now uncertain due to funding shortfalls, and FOTE in the KC-130 has been postponed indefinitely due to problems observed during DT on that platform.

### **TEST & EVALUATION ASSESSMENT**

The APR-39A(V)2 is undergoing a multi-platform test and evaluation program, which encompasses several platforms undergoing unique phases of their acquisition life-cycle. Contractor qualification testing and government independent validation and verification testing have proceeded relatively well considering the complexity and integration challenges of these systems. Management of diverse platform mission and integration requirements has also gone well. Issues involving the Test and Evaluation Master Plan have been resolved and FOT&E has been conducted on two platforms. Data collected and evaluated from these tests will help to determine if the systems should be deployed and serve the Program Manager in executing follow-on contract award options for additional units.

The Program Manager should pay particular attention to follow-on platform integration efforts that plan on utilizing existing lead platform (AH-1W) test and evaluation data to support fielding recommendations. In the past, there has been a tendency to rely too heavily upon existing lead platform data and to overly minimize unique platform-specific test requirements. It is very important that platforms adequately develop and implement robust test objectives that address unique aircraft platform integration and system-level performance. Each follow-on platform should plan on testing the integrated system's operational effectiveness and suitability and perform an assessment of upgraded performance against what is currently fielded.

## ROLLING AIRFRAME MISSILE (RAM) WEAPON SYSTEM

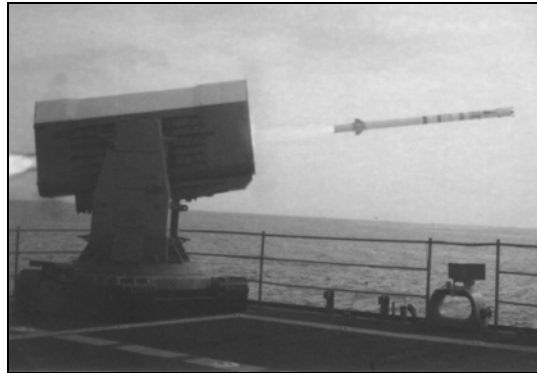

The Rolling Airframe Missile (RAM) program provides surface ships with an effective, low-cost, lightweight, self-defense system to engage and defeat anti-ship cruise missiles (ASCMs). The RAM Block 0 uses dual mode, passive radio frequency/infrared (RF/IR) guidance. Initial homing for RAM Block 0 is in RF, using an ASCM's RF seeker emissions. If the ASCM's IR radiation is acquired, RAM transitions to IR guidance. RAM Block 1 uses an improved, electro-optical proximity fuze and a new IR seeker and can be launched in an IR all-the-way mode, as well as the dual mode (passive RF, followed by passive IR) used by Block 0. Block 0 rounds are being configured with the new electro-optical fuze that is used in RAM Block 1. The Mod 0 launcher for RAM Block 0 was upgraded to accommodate RAM Block 1 and is designated the Mod 1 launcher. The launching system and missiles comprise the weapon system.

Most current RAM weapon system installations are integrated with the AN/SWY-2 or -3 combat system. On the LSD 41/49-class of amphibious ships, RAM is integrated with the Ship Self Defense System (SSDS) Mark 1. AN/SWY-2 installations use RAM as the only hard-kill weapon. AN/SWY-3 installations use both RAM and NATO Sea Sparrow systems as the hard-kill weapons. For future installations, it is intended that RAM be integrated with the SSDS Mark 2 on LPD 17-class and CVN 68-class ships (also NATO Sea Sparrow on the latter).

RAM Block 0 enhances ship self-protection against several RF-radiating ASCMs that have leaked past outer air defenses. RAM Block I extends that protection against several non-RF radiating missiles.

### **BACKGROUND INFORMATION:**

RAM was developed jointly by the United States and the Federal Republic of Germany. Block 0 IOT&E was completed in FY90. The DOT&E assessment was reported in the DOT&E FY90 Annual Report. Although a B-LRIP report was prepared, the Navy deferred its decision to proceed beyond LRIP. Due to this deferred decision, the B-LRIP report was not forwarded to the congressional defense committees until April 1994, prior to Block 0 missile and launcher full-rate production. The B-LRIP report concluded that the RAM weapon system was operationally effective against the preponderance of RF-emitting ASCMs, although there were exceptions. It also concluded that RAM Block 0 was not operationally suitable. These deficiencies were addressed prior to the decision to proceed beyond LRIP, with the new Block I missile program addressing the more fundamental deficiencies.

The RAM Block 1 OPEVAL was completed on the Self Defense Test Ship (SDTS) in August 1999. DOT&E concluded that RAM Block 1 is operationally effective and lethal against most current ASCMs, and is operationally suitable. An accompanying caveat was that those conclusions could not be decoupled from the combat system that was simulated on the SDTS.

In 1997, the resource sponsor requested that the Program Manager determine what RAM capability existed against helicopter, slow aircraft (less than 250 knots), and surface targets (HAS). This request stipulated that Block 1 anti-ASCM capability was to be retained, but was unaccompanied by operational requirements for the additional target set. Effort has been ongoing to develop missile software modifications to investigate that capability. Separate from, but concurrent with this effort, a new version of the launcher (Mod 3) will be introduced as an ordnance alteration to reduce acquisition and installation cost, address component obsolescence, and reduce manning. This launcher will be functionally equivalent to the Mod 1 launcher and will be capable of firing Block 1 missiles with the HAS software modifications. RAM HAS will be integrated with the Ship Self Defense System (SSDS) Mark 2.

#### **TEST & EVALUATION ACTIVITY:**

Activity consisted of firing a Block 1 missile that had undergone shipboard storage for the requisite period of time. This was an area that was not addressed during the OPEVAL and was conducted in conjunction with ship training at the Atlantic Fleet Weapons Training Facility in Puerto Rico during January 2001. This test was conducted again in July 2001 at the Naval Air Warfare Center (NAWC) Weapons Division sea range near Point Mugu, CA. Planning for FOT&E of RAM Block 1 and T&E of the RAM Helicopter-Aircraft-Surface (HAS) target mode was carried out as part of the TEMP update.

Further activity included preparations for contractor testing of the RAM HAS mode modification against HAS targets, using a RAM launcher located on San Nicolas Island on the NAWC sea range.

#### **TEST & EVALUATION ASSESSMENT:**

RAM Block 0. DOT&E's assessment of RAM Block 0 is that it is operationally effective against most of the RF-emitting ASCMs (based on the 1990 OPEVAL) and that it is now operationally suitable, after deficiencies were addressed. Performance against targets executing evasive maneuvers was never tested because these targets were not available, nor was the SDTS available for OT of RAM Block 0 against the most realistic threat attack profiles.

RAM Block 1. RAM Block 1, as supported by the SSDS Mark 1, integrating an AN/SPS-49A search radar, a CIWS Block 1B, and an AN/SLQ-32(V)3 electronic warfare system, is operationally effective against most current ASCMs. The CIWS Block 1B radar was essential in tracking targets and supporting RAM Block 1 launches. By no means can the operational effectiveness assessment of RAM Block 1 be divorced from the combat systems suite used in testing. RAM Block 1 is operationally suitable and is lethal against most current ASCMs. Its capability was examined against representative targets from all ASCM threat categories but one. That category is projected to have slow expansion and is currently populated by a single threat. FOT&E for Block 1 still needs to address missile capability against the threat category that was not tested during the OPEVAL; missile capability against a



supersonic, maneuvering sea-skimmer under more stressing conditions; and missile capability against ASCMs under conditions of EA to the combat system sensors, low visibility (high aerosol environment), and other IR sources.

For the threat category not tested in OPEVAL, there has been little progress in target development, with the only available target unrealistic in terms of no RF emissions and an IR signature lower than that of the predicted threat. For examining missile capability against ASCMs under conditions of electronic attack against the combat system sensors, the Program Manager considers this to be an area beyond his control and does not want to fund such T&E. Without such testing, the fleet users of the system will remain uninformed about their capability to defend themselves in an electronic attack environment.

Follow-on testing of RAM Block 1, intended to demonstrate missile reliability after requisite shipboard storage time, was conducted during stressing weather in January 2001. The PM reports that the unexpected results of this testing are still under review. The missile reliability test was conducted again in July, under more benign conditions, with the missile successfully intercepting its target.

RAM HAS Mode. Although it was understood that the program sponsor would issue detailed performance goals for RAM HAS in FY02 after completion of a performance characterization/evaluation phase, that no longer appears to be the case. The current proposal for fielding RAM HAS is to conduct:

- Combined DT/OT of Block 1A rounds (Block 1 rounds upgraded with HAS software) to demonstrate retention of Block 1 capability against ASCMs. This would occur in FY03, using the RAM Mod 1 launcher on the SDTS.
- DT in FY03-04 with the same missile round configuration against a small number of representative HAS targets (three surface, one helicopter, one light aircraft) from an upgraded RAM launcher operated in a stand-alone mode.
- DT/OT from a manned ship with the same missile round configuration against an aerial target drone in FY04, accompanied by a maintenance demonstration and evaluation of the Mod 3 launcher.
- DT/OT from a manned ship with RAM HAS fully integrated with SSDS Mark 2 against HAS targets. This is anticipated in FY05-06.

Navy's Surface Warfare Development Group would have full access to the test data to assist in defining capabilities and limitations of the HAS mode and to develop recommended tactics for fleet use. From an OT&E perspective, the proposed program is deficient in testing against the HAS target set. Further, the absence of operational requirements undermines objective assessment of OT results.

Both RAM Block 0 and Block 1 underwent LFT&E to evaluate their lethality against various ASCMs before proceeding to full-rate production. In late 2001, DOT&E designated RAM HAS for lethality LFT&E oversight based on its new target set. Because previous versions of the missile were not used or evaluated against helicopters, aircraft, or surface ships, there are few existing data on the RAM warhead's lethality against those targets. Testing is needed to gather basic information on the lethality of the weapon and to develop lethality simulations that can be used to predict lethality/effectiveness against those threats under a variety of scenarios. The LFT&E strategy for RAM HAS should include ground testing of the warhead against whole targets and/or components, flight testing, and simulation-based analyses.

This Page Is Intentionally Left Blank

## **RQ-8A FIRESOULT VERTICAL TAKEOFF AND LANDING TACTICAL UNMANNED AERIAL VEHICLE SYSTEM (VTUAV)**



The Vertical Takeoff and Landing (VTOL) Tactical Unmanned Aerial Vehicle (VTUAV) system is required to provide Reconnaissance, Surveillance, and Target Acquisition (RSTA) and communications relay capability in support of littoral operations for the Navy and Marine Corps. The purpose of the VTUAV system is to collect and pass information utilizing an airborne sensor platform that will provide the commander an extended and enhanced battlespace situational awareness. The VTUAV will incorporate an Electro-Optic/Infrared/Laser designator payload and should deliver timely, accurate, and complete information about the Commander's area of interest in near real-time.

A VTUAV system consists of air vehicles with payloads, a ground control element (ship-based for the Navy and vehicle-based for the Marine Corps), data link equipment, a remote data terminal, and associated ground support equipment. The Fire Scout air vehicle is based on the Schweizer Aircraft Corporation Model 330 manned turbine helicopter. The most significant change from the manned version is the replacement of the cockpit with a redundant flight control system including actuators, avionics, and software to support unmanned flight and payload operations. The Fire Scout has a gross takeoff weight of 2,550 pounds, cruises at 110 knots, and is intended to loiter on-station at 110 nautical miles for over 3 hours. An existing Allison Rolls Royce gas turbine engine powers the air vehicle. The ground control element will use the Tactical Control System (TCS) architecture to support system functionality and intelligence product dissemination to other C4I nodes.

The operational tempo calls for one VTUAV system to provide 12 continuous hours on-station at 110 nautical miles. This will be accomplished with more than one air vehicle and conducting relief-on-station operations. The command and control architecture using the tactical common data link and AN/ARC 210 UHF/VHF radio allows one ground station to monitor up to three air vehicles simultaneously, while receiving imagery from one of the airborne platforms.

### **BACKGROUND INFORMATION**

In November 1998, the JROC directed the Navy and the Army to pursue separate air vehicle solutions to satisfy their tactical UAV requirements, and the Navy submitted their operational requirement for a vertical takeoff and landing tactical UAV. The JROC subsequently validated the Navy's VTUAV ORD in January 1999, with the following Key Performance Parameters (KPPs): ability to conduct VTOL operations from a land-based site and all air-capable ships; ability to maintain a steady

state hover; automatic launch and recovery capability; 200 pound payload capability; deck restraining capability; ability to transfer control of the air vehicle from one ground control station to another; and ability to use either JP-5 or JP-8 heavy fuel. An interoperability KPP was added to the ORD that stipulates nine interfaces with which the VTUAV must be interoperable.

The Assistant Secretary of the Navy for Research, Development, and Acquisition (ASN(RDA)) approved Milestone II in January 2000. The first of two LRIP decisions will be for the purchase of one USMC VTUAV system consisting of three air vehicles, two remote data terminals, two ground control stations (GCS), shipboard GCS installation (although there may be problems here as described below), and associated support equipment, documentation, and training.

Prior to the Milestone II, 39 manned flights of the Model 379 for a total of 41 flight hours were accomplished. In January 2000, the first unmanned fully autonomous flight took place at NAWC China Lake, and the same prototype air vehicle (P1) successfully completed additional flight testing in June 2000. In November 2000, after a successful autonomous flight, the air vehicle crashed into the ground and was totally destroyed. Post-crash analysis attributed the mishap to an improperly installed radar altimeter antenna. As a result of the mishap, a manned air vehicle was inserted into the developmental flight test program.

## **TEST & EVALUATION ACTIVITY**

The manned air vehicle has flown over 60 flight hours in support of risk reduction flight testing. Flight testing with the manned platform continued in anticipation of availability of another unmanned prototype in late 2001, but support for the program inside the navy waned in late 2001, in favor of expected participation in other UAV programs.

Commander, Operational Test and Evaluation Force (COMOPTEVFOR) and the Marine Corps Operational Test and Evaluation Activity (MCOTEA) completed an operational assessment (OA, OT-IIA) during April 2001. The purpose of OT-IIA was to assess the potential operational effectiveness and potential operational suitability of the VTUAV system to support a decision to field low rate initial production lot 1 (LRIP 1). OT-IIA consisted of analyses of limited flight data, manned air vehicle data, and the developer's proposal. Subject matter experts from Marine Unmanned Aerial Vehicle Squadrons ONE (VMU-1) and TWO (VMU-2), Navy Fleet Composite Squadron Six (VC-6), and engineers from Ryan Aeronautical Center and Naval Air Systems Command were consulted.

## **TEST & EVALUATION ASSESSMENT**

COMOPTEVFOR's OA rated the VTUAV system as potentially operationally effective and potentially operationally suitable. The primary risk to the program is its dependence on the TCS for its ground control element; without the TCS, the VTUAV cannot be an effective system.

Final recommendations from the OA were to continue program development; however, fielding was not recommended until the current concept of employment with respect to forward basing or CONUS basing is reviewed. The OA also found that the VTUAV requirement to "be capable of conducting VTOL operations at 4,000 feet density altitude (DA) from all air-capable ships and be capable of conducting VTOL operations at 4,000 feet DA from an unprepared land-based site (threshold/KPP)" is operationally restrictive; that the Fire Scout air vehicle's inability to be delivered via vertical replenishment may unduly restrict the system's capability to operate from remote and austere

locations; that the VTUAV system will likely exceed set-up and pack-up timelines by several fold; and that although the VTUAV will likely meet the 25 meter spherical error probable/target location error requirement, it is inadequate for precision weapons guidance.

When fielded, it is envisioned that the VTUAV will be operated from LPD-class amphibious ships. As it now stands, this is the LPD 4 class. In the future, LPD 4 class ships will be retired and replaced by LPD 17 class ships. As a matter of Navy policy, systems are not allowed to achieve IOC on ships that will be retired in the next 5 years. Therefore, a production representative VTUAV system will not be installed aboard an LPD 4 class ship, and VTUAV must await introduction of LPD 17 to conduct OPEVAL aboard an amphibious ship. Delivery of the first LPD 17 will be approximately November 2004. A separate B-LRIP report must be generated after OT-IIIB to support the decision for full-rate production of the sea-based system.

A second shipboard issue is the required use of a landing grid in order to launch and recover the VTUAV. This grid was originally envisioned as a mobile platform that would be positioned on the flight deck for every launch and recovery of the VTUAV. However, the use of a mobile landing grid would prevent the VTUAV from meeting its ORD launch and recovery timelines. As a result, the landing grid is now envisioned to be a fixed, integral part of each LPD 17 flight deck. It might be too late to make the landing grid part of the initial ships of the LPD 17 class. In this case, early LPD 17 flight decks would have to be retrofitted with the landing grid, at a significant cost increase.

This Page Is Intentionally Left Blank

## SEAWOLF SSN 21 CLASS ATTACK SUBMARINE AND AN/BSY-2 COMBAT SYSTEM



The *Seawolf* (SSN 21) Nuclear Attack Submarine is designed to rapidly deploy to hostile ocean areas and deny their use to the enemy, clear the way for strikes by other friendly forces, and engage and destroy enemy submarines, surface forces and land targets. Secondary missions are mine and special warfare. *Seawolf* is designed to be a quiet, fast, heavily armed, shock resistant, survivable submarine.

The AN/BSY-2 Submarine Combat System is designed to support SSN 21 in all mission areas. It is required to detect, classify, localize and track targets, platforms, and weapons by means of onboard active and passive sensors and with target information from other platforms and external detection systems. The combat control subsystem provides setting and control of weapons, over-the-horizon targeting, combat systems management, improved target motion analysis, piloting and navigation functions, and automatic contact correlation. It includes the weapon launch equipment for the MK 48 Advanced Capability torpedo and the Tomahawk Missile. Acoustic hardware includes a truncated 24 ft diameter spherical receive array, a 15 ft diameter hemisphere active transmit array, the Wide Aperture Array (WAA), a low frequency bow array, two towed arrays, and a mine detection and avoidance high frequency array.

### **BACKGROUND INFORMATION**

The *Seawolf* program began in 1982 and was approved for conceptual design in 1983. The preliminary design was authorized in 1983 and was completed in 1985. Approval for lead ship production was granted in 1988.

*Seawolf* began initial sea trials in July 1996. She demonstrated unprecedented speed during her first trial. Following delivery, *SEAWOLF* began acoustic trials, which were completed in November 1997. *Connecticut* (SSN 22) went to sea in 1998. The third and final *Seawolf* class submarine, *Jimmy Carter* (SSN 23), is under construction with delivery scheduled in FY04. *Jimmy Carter* will be uniquely outfitted with an additional hull section lengthening the ship for special missions and R&D projects.

The *Seawolf* LFT&E plan included a 1/4 scale Shock Model Test Vehicle that underwent underwater shock and hull whipping. Shock tests were conducted in the A/B-1 shock test vehicle in 1995 with shock testing of a surrogate Main Propulsion Unit (MPU) and the Wide Aperture Array (WAA) sonar fairing. A series of underwater shock tests of major hull penetrations and related components was

conducted using the Navy's A/B-1 test fixture at the Aberdeen Test Center in 1998-1999. Other testing of smaller hull penetrations has been performed using the Navy's Full Scale Section (FSS-5 and FSS-8) shock test vehicles and Paddlewheel shock test fixture. Extensive shock qualification testing of *Seawolf* internal vital components has been accomplished using Floating Shock Platforms (test barges) and standard Navy shock test machines. As of October 2001, approximately 5,852 of 6,509 *Seawolf* components had been shock qualified. The LFT&E Plan for *Seawolf* featured a full ship shock test (FSST) of the completed ship. This was not accomplished due to legislative action that specifically prohibited the Navy from expending funds to perform the FSST.

## **TEST & EVALUATION ACTIVITY**

DOT&E approved Change 1 to Revision 4 to the TEMP in October 2000. This change aligned initial and follow-on operational testing consistent with agreements reached between the Navy and DOT&E. This realignment has supported the Navy's desire to deploy *Seawolf* as soon as possible by initially testing only those mission profiles that *Seawolf* is expected to use during her initial deployment. Other mission profiles, including Battlegroup Operations and Special Warfare will be tested before the ship is employed tactically in those mission profiles. Follow-on operational testing and evaluation (FOT&E) will also be needed to assess planned propulsor and sonar improvements.

The *Seawolf* OPEVAL was completed in FY01. Warm water and cold water testing was performed by USS *Seawolf*. Minefield testing was conducted by USS *Connecticut*. USS *Connecticut* then deployed for five weeks to the Arctic and surfaced at the North Pole in June 2001. In September 2001, USS *Connecticut* completed a test of the missile strike capability while performing as launch platform for a Cruise Missile Program Operational Test Launch.

As required by the TEMP LFT&E strategy, the Navy prepared a *Seawolf* (SSN 21) Class Vulnerability Assessment Report (VAR) that provides an overall assessment of vulnerability to threat weapons that may be encountered in combat. The VAR was completed in January 2001; but due to the lack of an FSST, DOT&E's LFT&E evaluation may not provide a complete ship survivability picture.

## **TEST & EVALUATION ASSESSMENT**

In 2001, progress was made in several deficiency areas pointed out by OPTEVFOR's 1999 Operational Assessment, the most significant being in weapon launch, handling and storage. These are no longer major concerns as demonstrated by the operations of the USS *Connecticut*, which had many updates installed during her Post Shakedown Availability (PSA). Progress was also demonstrated on Covertness and Detection. At the completion of OPEVAL in 2001, tactical development was continuing to be developed.

The *Seawolf* (SSN 21) Class VAR addresses the LFT&E issues and provides an overall assessment of vulnerability to threat weapons that may be encountered in combat. LFT&E issues addressed include the ship's vulnerability to torpedoes and mines and the ship's ability to perform its mission after exposure to specified levels of underwater shock intensity. The VAR applies to both SSN 21 and SSN 22, but it does not apply to SSN 23 because it is a much different ship.

The Navy's VAR was largely based on component and subsystem tests and analyses. But the Navy cannot fully address all the agreed upon LFT&E issues without completing the FSST. This leaves



the overall *Seawolf* LFT&E program as incomplete because major aspects of ship survivability remain unknown. The data voids will impact DOT&E's independent *Seawolf* vulnerability assessment.

The *Jimmy Carter* (SSN 23) design is substantially different from the *Seawolf* (SSN 21) configuration, with upgrades that may significantly affect survivability. In addition to lengthening the hull by approximately 100 feet and adding nearly 2,500 tons displacement, other modifications include changes to the pressure hull, adding a dry deck shelter, inserting an ocean interface section as well as installation of numerous new systems that should be shock qualified. Therefore, in December 1999, DOT&E designated *Jimmy Carter* as a covered product improvement program on the LFT&E oversight list. DOT&E emphasized the need for a new TEMP, including a new LFT&E strategy to the Assistant Secretary of the Navy Research, Development, and Acquisition (ASN (RDA)) in July 2000. The Navy has resisted this designation and requirement claiming that 100 additional feet of hull, new mission, and 2,500 tons of displacement and approximately \$1 billion cost, although a major product improvement, do not significantly affect ship survivability.

This Page Is Intentionally Left Blank

## SHIP SELF DEFENSE SYSTEM (SSDS)

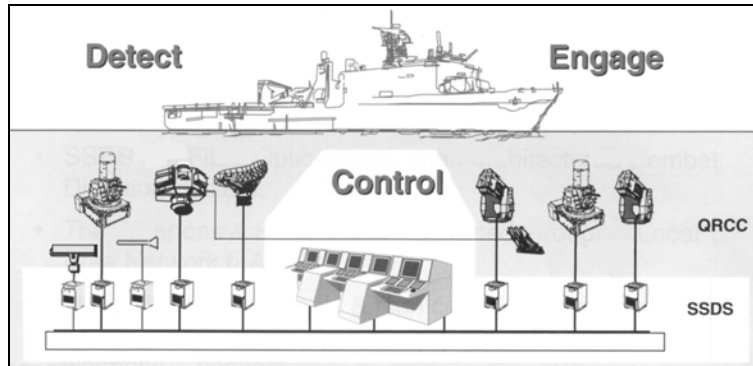

The Ship Self Defense System (SSDS) is designed to expedite the detect-through-engage process on amphibious ships and aircraft carriers against anti-ship cruise missiles (ASCMs). SSDS, consisting of software and commercial off-the-shelf (COTS) hardware, integrates sensor systems with engagement systems. Although SSDS will not improve capability of individual sensors, it enhances target tracking by integrating the inputs from several different sensors to form a composite track. Similarly, SSDS will not improve capability of individual weapons, but should expedite the assignment of weapons for threat engagement and provide a recommend engage display for operators, or if in automatic mode, initiate weapons firing, ECM transmission, chaff or decoy deployment, or some combination of these.

SSDS Mark 1 integrates previously stand-alone sensor and engagement systems for LSD 41-class ships, and SSDS Mark 2 is the combat direction system for aircraft carriers and other amphibious warfare ships.

### **BACKGROUND INFORMATION**

OPEVAL of SSDS Mark 1 was conducted during June 1997, in accordance with a DOT&E-approved plan and TEMP, to support the B-LRIP decision for procurement of SSDS. Based on OPEVAL results, SSDS Mark 1 was determined to be operationally effective against subsonic, low altitude ASCMs and operationally suitable. Full production was authorized in March 1998, with total procurement of 58 units. However, only the LSD 41 class will receive SSDS Mark 1. The rest of the production buy will be an upgrade to the Mark 2 configuration, which will incorporate functionality of the Advanced Combat Direction System (ACDS) Block 1 and provide the interface for integration with the Cooperative Engagement Capability (CEC). FOT&E of Mark 1 was conducted on-board the remotely controlled Self Defense Test Ship (SDTS) during FY99 at the Naval Air Warfare Center, Weapons Division Sea Range at Point Mugu, CA, with a separate phase for operational suitability issues conducted in FY01.

### **TEST & EVALUATION ACTIVITY**

Mark 1. The operational suitability portion of the FOT&E deferred from FY99 was conducted on USS *Oak Hill* inport in Norfolk, VA.

Mark 2. Activity consisted of further definition of the overall T&E program and early testing of the Mod 0 version intended for USS *Nimitz*.

### **TEST & EVALUATION ASSESSMENT:**

Mark 1. As a result of the FY97 OPEVAL and FOT&E to date, Mark 1 is considered operationally effective against most current ASCM raids. It is operationally suitable, although improvement is still required in officer and tactics training.

Mark 2. The proposed T&E program includes a land-based test phase at Wallops Island, VA, and at-sea phases on two aircraft carriers (CVNs 68 and 76) and the LPD 17. Because it incorporates ACDS Block 1 functionality, SSDS Mark 2 will require assessment of performance in several warfare areas. These include Air, Surface, Strike, Amphibious, and others. Further, the Air Warfare area T&E requires an additional phase to assess ship self-defense against ASCMs. This requires Mark 2 integrating the sensor and engagement subsystems of the applicable ship class combat systems while engaging ASCMs or acceptable surrogates as targets. Moreover, since the systems on these ships are short-range air defense systems, safe and effective testing requires use of an SDTS capable of being remotely operated during operationally realistic ship air defense scenarios. Given that the LPD 17 is the first new ship class receiving SSDS Mark 2, OT&E of Mark 2 should be combined with the IOT&E for the LPD 17.

The existing TEMP is out of date and fails to address Mark 2 T&E. A draft TEMP has not been submitted for review. Navy operational requirements for Mark 2 are expected in the near future and a TEMP update is expected during FY02.

The Navy warfare sponsor for LPD 17 is resisting funding realistic operational testing of the LPD 17 combat system on a self-defense test ship. Cited among reasons for such resistance are the inordinate cost of installing SSDS Mark 2 and the associated sensors and RAM on an SDTS. However, without such testing, the IOT&E for LPD 17 will be inadequate.

## STANDARD MISSILE-2 (SM-2)



The Standard Missile-2 (SM-2) is a solid propellant-fueled, tail-controlled SAM fired by surface ships. It was designed to counter high-speed, high-altitude anti-ship cruise missiles (ASCMs) in an advanced ECM environment. Its primary mode of target engagement uses command mid-course guidance with radar illumination of the target by the ship for missile semi-active homing during the terminal phase. The Block II version of SM-2 includes a signal processor to provide less vulnerability to ECM, an improved fuze, and focused-blast fragment warhead that provides better kill probability against smaller, harder targets, and new propulsion for higher velocities and maneuverability. The SM-2 can be used against surface targets.

A Block III version of SM-2 provides improved capability against low altitude targets. A modification to this version, designated Block IIIA, extends capability to even lower altitudes and includes a new warhead that imparts greater velocity to warhead fragments in the direction of the target. These SM-2 versions are provided as medium range (MR) rounds that can be fired from Aegis rail launchers, Aegis vertical launch systems (VLS), and Tartar rail launchers. Another MR version, designated Block IIIB, added a passive infrared seeker for an alternate guidance mode. A Block IV version was developed to provide extended range, improved cross-range, and higher altitude capability for Aegis VLS ships, as well as improved performance against maneuvering targets and complex ECM.

### **BACKGROUND INFORMATION**

Full production approvals for SM-2 Blocks have been as follows: Block II was approved in December 1986; Block III in June 1988; Block IIIA in February 1992; and Block IIIB in September 1996. Block IV was approved for LRIP in May 1995. Further procurement was deferred, pending development of the Block IVA missile for the Navy Area Theater Ballistic Missile Defense (NATBMD) program. The Block IV program was restructured with the intention to proceed to DT&E/OT&E and support a full production decision if technical problems were encountered during development of the SM-2 Block IVA that preclude its retention of Block IV capability (never fully determined) against anti-air warfare threats. While the number of at-sea flight tests of Block IV is small, those tests have supported partial validation of the model used to predict performance.

The NATBMD program, including SM-2 Block IVA, was terminated in December 2001.

## **TEST & EVALUATION ACTIVITY**

For both Block IIIB and Block IV, capability in various environments was investigated during flight tests conducted in conjunction with combat system ship qualification trials of Aegis ships. There was no formal T&E.

## **TEST & EVALUATION ASSESSMENT**

Based on the 1996 OPEVAL results, DOT&E concluded that SM-2 Block IIIB is operationally effective and suitable, although there was degradation in minimum range performance. FOT&E conducted in December 1998 verified correction of the loss of minimum range performance. Further FOT&E was conducted during April 1999, demonstrating capability against an actual anti-ship cruise missile with a Block IIIB that had undergone a more representative storage period onboard a fleet ship. Additional FOT&E was conducted in July 1999 to characterize and understand the potential of fratricide in certain operational environments. Further tests, intended to characterize and understand capability in specific operational environments, will be conducted in conjunction with training events.

In view of the NATBMD program termination, it is not clear what path the Navy intends to follow in order to bring the Block IV or IVA improvements to air defense. When that is determined, T&E planning will follow. However, it is known that surrogates to represent supersonic, sea-skimming, maneuvering ASCM threats will be required for the OT&E. Currently, very few of these surrogates are available. VANDAL targets, being used for fleet training and acquisition program T&E, will be depleted by early FY03. MA-31 target availability is an uncertainty. The GQM-163A Supersonic Sea Skimming Target (SSST), currently in development, is supposed to be available in mid-2004. Further, a new ASCM threat has emerged for which there is no credible surrogate to use as a target. DOT&E has notified the Navy that it expects OT&E of air defense systems to include testing against this threat.

LFT&E is discussed in Section VI under the NATBMD report.

## **STANDOFF LAND-ATTACK MISSILE EXPANDED RESPONSE (SLAM ER)**



The Standoff Land-Attack Missile- Expanded Response (SLAM-ER) is a deployed precision tactical weapon that provides Joint Force and Carrier Battle Group Commanders with a standoff precision strike capability and is launched from carrier battle group aircraft. An advanced derivative of its predecessor (SLAM), the SLAM-ER has longer range, reduced susceptibility to countermeasures, increased probability of kill against hardened targets, and improved guidance with an integrated Global Positioning System and Inertial Navigation System. Improved user interfaces for mission planning and an automated target acquisition (ATA) capability to aid the pilot in finding and killing targets are being retrofitted to both SLAM and SLAM-ER.

SLAM-ER seeks to provide incremental improvements in range and penetrating lethality. ATA provides aimpoint cueing assistance to the pilot in man-in-the-loop (MITL) mode in cluttered scenes, marginal weather, and countermeasures environments. This is accomplished by employing scene matching technology (hardware and software modifications). The ATA may also be used in a stand-alone mode when MITL is not feasible or desirable. SLAM-ER uses a newly developed titanium-cased warhead to achieve greater hard target penetration and lethality.

### **BACKGROUND INFORMATION**

SLAM-ER entered EMD after a Milestone IV/II decision in FY95. The Navy decided to procure the FY96 buy of SLAM in the SLAM-ER configuration, avoiding future retrofit costs. The LRIP I decision was made in April 1997, with LRIP II approved in April 1998. OPEVAL was conducted from August 1998 to May 1999. As detailed in the 1999 Annual Report to Congress, DOT&E assessed that during OPEVAL, SLAM-ER was not operationally effective and not operationally suitable as tested. DOT&E did not concur with COMOPTEVFOR's assessment that SLAM-ER was operationally effective but not suitable. An LRIP III decision was made in August 1999. These three production decisions totaled over 100 missiles. The program corrected deficiencies and a Verification of Correction of Deficiencies (VCD) Phase examined all corrected deficiencies to ensure the fleet had an operationally effective and suitable system upon introduction. DOT&E monitored the VCD phase and assessed that SLAM-ER is operationally effective and suitable as tested during the VCD phase. Milestone III and the full-rate production decision were approved in May 2000.

## **TEST & EVALUATION ACTIVITY**

FOT&E (OT-III A) began in September 2001 to evaluate the ATA capability. The test plan incorporates one developmental test flight (DT-1), three developmental/operational test flights (DT/OT-1, 2, and 3), and one operational test flight (OT-1). Initial testing included several captive carry flights of the missile with positive assessments by the operational test pilots. Initial developmental tests suffered from missile system failures not related to ATA: first, a hang fire and then failure of the missile wings to deploy after launch. These were followed by three effective tests (DT-1; DT/OT-1; DT/OT-2). One event remains – operational test of the missile with ATA (OT-1) against a land-based target in spring 2002. Testing of missile effectiveness against ships (AsuW) is planned but not completed.

## **TEST & EVALUATION ASSESSMENT**

DOT&E has approved the TEMP and test plan and will monitor and report on the final operational test flight (OT-1). DOT&E will also assess overall missile reliability given the two missile reliability failures that occurred during initial ATA tests: one missile was a hang fire and the other missile failed to deploy its wings after launch.

Both the ATA and AsuW modes employ the new SEM 1.6 software package that is the configuration for all fleet deployments of missile in the foreseeable future. Testing data to date suggests that ATA mode could be useful in cueing the pilot. Final evaluation will be based on operational test data.



## STRATEGIC SEALIFT PROGRAM (SSP)



The Strategic Sealift Program (SSP) is a focused logistics program that produces ships to transport or provide afloat pre-positioned logistic support for a projected military force. This mission is a vital part of dominant maneuver in the current power projection environment. The notional cargo per ship is envisioned as equipment for one-third of a heavy Army brigade task force and its supporting supplies. SSP projects and sustains the force by providing strategically mobile forces, ready on arrival. The SSP ships are Large, Medium Speed, Roll-on/Roll-off (RO/RO) vessels referred to as LMSR. Their sizable dimensions are 950 feet long, 106 feet wide, and 55,000 long ton displacement; capable of steaming at 24 knots. The sealift ships are expected to be capable of self-sustained RO/RO and Lift-on/Lift-off (LO/LO) operations at a pier and in In-The-Stream (ITS) scenarios through stern and side port ramps to lighterage via a RO/RO Discharge Facility.

The LMSR ships are not armed and do not have a combat system. They do have a C3I suite sufficient to perform their intended mission in conjunction with other naval vessels.

### **BACKGROUND INFORMATION**

SSP is scheduled to deliver 20 ships, five of which are conversions of existing commercial container vessels, and fifteen of which will be newly constructed ships. Officially, there will be 19 LMSR ships in the SSP. The twentieth ship had been converted to a Maritime Pre-positioning Force ship. All LMSR ships use common Navy-furnished cargo handling systems. Three contractors are completing construction of the LMSRs. A performance type procurement description was used, with the result that ship configurations differ as the respective builders have interpreted the mission requirements.

As authorized in the acquisition strategy, developmental testing has been limited, focusing on production assurance testing by government agents in conjunction with the builders. Navy, U.S. Coast Guard, and American Bureau of Shipping representatives witnessed systems and integration testing.

The current TEMP was approved in June 1996. In view of the single ship mission and similarities in the LMSR configurations, it treats the ships in two groupings: conversion ships and new-construction ships. The TEMP outlines a mix of operational test events and operational assessments designed to address the variance among the separate designs. Two IOT&E's were planned, one of a conversion ship and the other of a new construction ship. Operational assessments of conversion and new construction ships would examine the operational effectiveness and suitability of the ship designs not subjected to full operational testing.

The IOT&E (OT-IIA) of the National Steel Shipbuilding Company (NASSCO) conversion LMSR ship was planned and conducted in accordance with the DOT&E-approved TEMP and OT Plan. OT-IIA was conducted during September 1996, aboard United States Naval Ship (USNS) SHUGHART in Savannah, GA, at sea and in Hampton Roads, VA, and in conjunction with a planned Army sealift deployment exercise, which moved a representative load of Army equipment (over 1,000 pieces, including tanks, trucks and various helicopters) from the 3d Infantry Division. Limited ITS operations were conducted at Ft. Story, VA.

### **TEST & EVALUATION ACTIVITY**

The Avondale Industries new construction LMSR IOT&E (OT-IIB), originally scheduled for July 1998, had been delayed by several production issues and by the difficulties of providing sufficient Army-unit equipment for the test. In September 2001, after extensive coordination with the Commander, U.S. Central Command (CENTCOM), USNS SEAY was selected as the test platform to conduct OT-IIB while supporting CENTCOM's BRIGHT STAR 01/02 Exercise. This test was designed to examine the Avondale's new construction ship as part of the strategic sealift system and focused on the surge sealift mission. Due to the failure of one of the ship's controllable reversible propellers, and the events of September 11, 2001, this test was postponed.

The TEMP update is in final development and should be forwarded to OSD for approval shortly.

### **TEST & EVALUATION ASSESSMENT**

The first phase IOT&E event (OT-IIA) found the NASSCO conversion LMSR to be potentially operationally effective and potentially operationally suitable. No significant deficiencies had been observed from the operational testing, which is focused on ship capabilities, with the exception of comprehensive ITS operations in sea-states; however, no shortfalls have been observed in load planning and training of personnel for executing the mission, notwithstanding an adequate doctrine that is not yet in place to guide execution. Considerable data has been collected in the OTA assessments of the Newport News Shipyard conversion ships and the NASSCO new-construction LMSR, but the reports of those assessments have not been delivered.

In-The-Stream (ITS) RO-RO operations (doctrine, training, expected offload flow rate, and stern ramp operations) and LO-LO capabilities, including control of crane pendulation, are two general areas of concern. ITS operations have not been tested adequately and are specific areas of concern. It is highly probable that LMSR ship mission performance will be hindered by existing deficiencies in the Strategic Sealift System. Shortfalls in the Sea State 3 lighterage system (capability, inventory, and doctrine) will adversely affect the United States' ability to project power in a timely manner in situations where adequate port facilities are not available. A total of only 113 ports were identified as having sufficient depth of water and length of berth to allow pier side offload of an LMSR and only 31 of these are in locations other than the Americas, Europe, Australia, and Japan. Although a force may get to a crisis in a timely fashion, in some situations, it will be challenged to get its equipment off the ship. In the Stream offload of a tactically representative equipment load has not been demonstrated under operationally realistic conditions. The overall class assessment of ITS operations, which was to be conducted during the BRIGHT STAR 01/02 Exercise, would have collected minimal test data and been insufficient to complete an evaluation of the ship's ability to unload "in-the-stream." An FOT&E will be required to demonstrate ITS operations under realistic conditions, and additional testing of ITS offload capability in Sea State 3 must be performed when Sea State 3-capable lighterage is developed.

## SUBMARINE EXTERIOR COMMUNICATIONS SYSTEM (SubECS)



The Submarine Exterior Communications System (SubECS) is an umbrella program, which integrates 15 smaller acquisition programs and Commercial Off-the-Shelf (COTS) components into a system that supports Network Centric Warfare. The goal of this effort is a communications system that is common across all submarine classes, is interoperable with the planned DoD C4I infrastructure, and will support the Navy's Copernicus Information System Architecture, the Joint Technical Architecture, the Global Command and Control System Maritime, and the Joint Maritime Communications System.

SubECS will support the steady infusion of new technology and the modernization and replacement of obsolete equipment to allow prompt, sustained, and synchronized operations with Joint U.S. and multinational forces.

SubECS upgrades the communications systems of all existing and planned submarines (*Los Angeles* Class, *Seawolf* Class, *Trident* Class, and *Virginia* Class) and is being fielded in four major phases. Phase 1 will provide increased interoperability, data rate, and aggregate throughput to the submarine; Phase 2 will provide enhanced message processing and distribution; and Phase 3 will replace remaining legacy transceivers and cryptographic hardware with digital modular radios and programmable cryptographic solutions. During these phases, software and hardware upgrades to equipment from previous phases will be implemented as necessary to keep up with commercial technologies. By Phase 3, a functionally common radio room baseline will exist for all in-service submarine classes. The *Virginia* Class (SSN 774) ECS is being developed and integrated as part of new construction using the construction shipyard as the integrator. The *Virginia* ECS will build on SubECS Phase 3 and is the Phase 4 of SubECS. The goal for the out-years is that all in-service submarines will be upgraded to the *Virginia* ECS plus any necessary technology insertions, maintaining a common state-of-the-art radio room on all submarine classes.

### **BACKGROUND INFORMATION**

The test concept for SubECS involves operational testing for each smaller sub-component and end-to-end system testing for each major phase. Each sub-component program will undergo operational testing before it is introduced into the Fleet. Each SubECS Phase will undergo a land-based Operational Assessment and land-based TECHEVAL, which will be used to certify the system for installation on a submarine. Subsequent to on-board installation, each SubECS Phase will then undergo an at-sea TECHEVAL (for those tests not completed in the land-based radio room) and an OPEVAL. The *Virginia* Class ECS land-based testing will occur in the Combat Control System Module Off-hull Assembly and Test Site during *Virginia* class submarine construction at the Electric Boat Company in

Groton, CT. At-sea operational testing of the *Virginia* ECS will occur concurrently with the overall OPEVAL of the USS *Virginia* (SSN 774).

In June 2000, FOT&E was satisfactorily completed in the *Trident* submarine variant of the Submarine Low Frequency (LF)/Very Low Frequency(VLF) Versa Module European Bus (VMEbus) Receiver (SLVR), which incorporated the new KOV-17 embedded encryption device, a space-saving improvement. SLVR is now being introduced to fleet *Trident* submarines and to some *Los Angeles* submarines.

### **TEST & EVALUATION ACTIVITY**

The first phase of TECHEVAL for the SubECS Phase 1 program was conducted at the Land Based Submarine Radio Room at the Naval Undersea Warfare Center Division, Newport, RI, during February and March 2001. The second TECHEVAL phase will be conducted on an operational submarine platform. At-sea OPEVAL is scheduled for FY02 on a *Los Angeles* class SSN.

An OPEVAL was conducted by COMOPTEVFOR of the Submarine High Data Rate (SubHDR) Antenna System in *USS Providence* (SSN 719) in March 2001. A maintenance demonstration was conducted at the Submarine EHF Satellite Communications Integration Facility Lab, Naval Undersea Warfare Center, Newport, RI. Due to satellite limitations, the scope of OPEVAL was limited to testing Extremely High Frequency Low Data Rate capability on those satellites available to the test platform. Additional system performance capabilities will be tested during a phase of FOT&E. These limitations excepted, all test objectives were accomplished.

### **TEST & EVALUATION ASSESSMENT**

Operational testing occurred on SubECS sub-components in accordance with their individual Navy-controlled TEMPs, and FY01 saw the start of the first SubECS integrated phase testing in accordance with the Capstone TEMP. The introduction of the Capstone TEMP will provide *Virginia* and all in-service submarines with a framework in which formal communications system requirements can be addressed. DOT&E concurs with the dual strategy of testing both individual subsystems and major system upgrades.

The *Virginia* ECS program implemented a phased delivery approach to mitigate risk that delays the selection of a final configuration as long as possible to reduce changes, both anticipated and unanticipated, in the Navy's C4I acquisition programs. *Virginia*'s limited ECS space—9 rack versus 14 on *Los Angeles* class—also makes it important to delay *Virginia*'s final configuration as long as possible in order to take best advantage of the latest miniaturization developments. DOT&E continues to evaluate the *Virginia* risk as moderate but acknowledges that the Navy's approach seems sound. Navy initiatives to field an early *Virginia* ECS build on the *Seawolf* class, if funded, would further reduce risk, at least to the *Virginia* class ECS.

Significant delays in the launch of MILSTAR satellites has pushed complete Submarine High Data Rate (SubHDR) antenna operational testing to several years past the fleet introduction date. The Navy decided to operationally test the SubHDR antenna in FY01 as much as practicable and proceed on with fleet introduction, even though the antenna's higher data rate capability cannot be tested until a MILSTAR II becomes available. DOT&E agrees that this course of action, although not ideal, is a reasonable approach.

## TACTICAL AIRCRAFT MISSION PLANNING SYSTEM (TAMPS)



The Tactical Automated Mission Planning System (TAMPS) is a computer-based method for planning routes and the delivery of weapons for naval aviation systems. TAMPS provides an automated system for rapidly processing large quantities of digitized terrain, threat and environmental data, aircraft, avionics, and weapon systems parameters to assist in strike planning and other missions. The system was also designed to provide data transfer from mission planning computer to the tactical computers aboard fixed and rotary wing aircraft, standoff weapons, and unmanned air vehicles.

The system's software interacts with other naval C<sup>4</sup>I systems so that planners are able to use current weather and intelligence databases. Its modular and open system architecture was developed to satisfy specialized aircraft weapons and avionics systems requirements while maintaining consistent displays and interactions across all platforms. The system produces a variety of products used by naval aviators during combat missions: digital loads, strip route charts, and pilot kneeboard cards.

There are two configurations for TAMPS 6.2.1: stand-alone and networked in a mission-planning, local area network (MPLAN). The stand-alone system uses Sun UltraSPARC 1200 or 1300 workstations. The MPLAN configuration allows shipboard collaborative planning within a carrier air wing/battle group. Mission planning is performed on personal computer client workstations connected to an Enterprise 4000 server. A Sun UltraSPARC 2300 is used as a backup server.

After TAMPS 6.2.1 development has been completed, no future upgrades are planned. The Navy will migrate mission planning to the Joint Mission Planning System (JMPS) when that system becomes operational. The only TAMPS activity planned after 6.2.1 will be to sustain current users.

### **BACKGROUND INFORMATION**

TAMPS was initially designed in December 1985. No IOT&E was conducted prior to fleet release. During the 1990s, TAMPS was upgraded to Version 6.0, which first underwent FOT&E in late 1994 (this test phase was designated OT-IIIC). Other releases of the 6.X versions have also undergone FOT&E. These releases have added capabilities, attempted to correct deficiencies, and have moved towards off-the shelf products and a more networked, collaborative mission-planning environment. As TAMPS evolved, it focused less on aircraft mission planning and more on smart weapon deliveries and as a conduit for transferring data to and from aircraft computers. Aircraft and weapon computers have become increasingly dependent on TAMPS for mission planning, aircraft computer programming, and data transfer. The JMPS, which is currently under development, will eventually become the mission planning system used by both the Air Force and the Navy and replace TAMPS.

FOT&E of versions 6.2 and 6.2K was completed in June 1999. Version 6.2 was found to be operationally effective and suitable for some F/A-18 mission planning, but not operationally effective for AH-1W tactical waypoints and routes data loading. Version 6.2K was determined to be operationally effective for some specific types of weapons planning and data loading, but some key aspects of operational effectiveness were not tested due to test limitations. Version 6.2K was found to be operationally suitable in a stand-alone configuration, but not operationally suitable in the MPLAN configuration. Specific deficiencies cited included continued problems with ARC-210 radio; planning printouts that were of limited value; sensitivity to dropped network connections; a slow process to restore replication server failures; incompatibility with a shipboard environment and storage cases; inadequate training (for both operators and administrators); and inadequate documentation. Fleet release was recommended only in the stand-alone configuration and only for a specific set of weapons; fleet release was not recommended for the MPLAN configuration.

TAMPS 6.2.1 is the latest version and is supposed to correct the deficiencies encountered in 6.2 and 6.2K and improve stability and performance in the MPLAN configuration. A new user interface was added, the operating system upgraded, and a new contractor team was hired to take over system development.

### **TEST & EVALUATION ACTIVITY**

FOT&E of version 6.2.1 began in January 2001. Test and Evaluation Squadron NINE (VX-9) conducted the test, primarily with their mini-LAN configuration at China Lake and when Carrier Air Wing ONE used TAMPS during the Air Wing detachment Fallon in April. Testing of some specialized functionalities (e.g., E-2C, P-3) was a smaller subset of the overall test and was conducted at other locations. Operational testing was conducted in accordance with a TEMP and test plan approved by DOT&E. In spring 2001, operational testing of version 6.2.1 was suspended due to three major deficiencies in weapon mission planning: F-14 Joint Direct Attack Munition (JDAM) load failures; Joint Stand Off Weapon (JSOW)/JDAM Combined Mission Planning Module (CMPM) crashes; and JSOW/JDAM CMPM failures associated with expired data loads from other weapons. Software changes made during operational test corrected each of these major deficiencies and testing resumed in June 2001. A final report was made by COMOPTEVFOR on December 20, 2001.

### **TEST & EVALUATION ASSESSMENT**

COMOPTEVFOR reported that TAMPS 6.2.1 was operationally effective for creating data loads for five aircraft (F-14B/D, E-2, S-3B, SH/HH-60, P-3); weapon planning for four weapons (JDAM, JSOW, HARM, SLAM-ER); and for use with F/A-18 aircraft tactical software avionics.

COMOPTEVFOR also reported that TAMPS 6.2.1 was operationally suitable in stand-alone and networked environments provided the system was adequately supported by uniquely qualified support personnel, "ship-riders," that currently augment deploying units.

Aircrew primarily use TAMPS to transfer weapon data between desktop computers and aircraft and weapon computers. They rarely, if ever, use it in other areas of mission planning. As highlighted by COMOPTEVFOR, the Navy must pay particular attention sustaining adequate funding for the uniquely qualified ship riders whose system maintenance skills keep TAMPS operationally suitable while deployed. The Navy plans to begin using JMPS when development of this system is completed. If JMPS replaces TAMPS as planned, TAMPS 6.2.1 is the final version of TAMPS that will be evaluated.

# TOMAHAWK

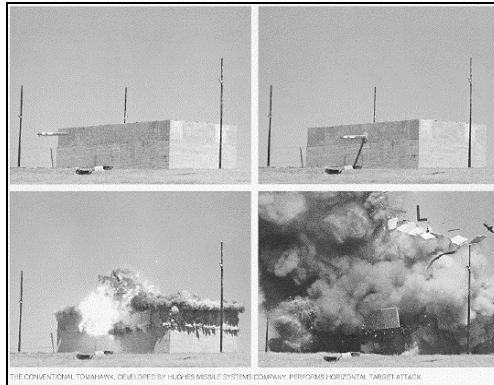

Tomahawk is a long-range cruise missile designed to be launched from submarines and surface ships against land targets. Three primary variants are currently operational: (1) Tomahawk Land Attack Nuclear (TLAM-N) (not deployed); (2) Tomahawk Land Attack Missile-conventional (TLAM-C); and (3) Tomahawk Land Attack Missile-conventional submunition (TLAM-D). Each missile is contained within a pressurized canister to form an all-up-round (AUR). The Combat Control System (CCS) on submarines or the Tomahawk Weapon Control System (TWCS) on surface ships performs engagement planning, missile initialization, and launch control functions aboard the launch platform. Targeting, mission planning, and distribution of Tomahawk tactical data are supported by the Tomahawk Command and Control System (TC2S).

The Tactical Tomahawk program began in FY98 as a restructure of the earlier (FY94-98) Tomahawk Baseline Improvement Program. Tactical Tomahawk represents a considerable leap forward in technology compared with Block III Tomahawk. Designated C<sup>3</sup> nodes will be able to communicate with the missile in-flight and direct it to pre-planned alternate targets or change its mission plan to attack new targets. While in-flight, the missile will be able to transmit its health, status, and limited imagery to the C<sup>3</sup> nodes.

## **BACKGROUND INFORMATION**

Early in FY01, the AUR program office (PMA-280) announced a six-month delay in the Tactical Tomahawk AUR development and production program. This delay led to an extensive restructuring of the Baseline IV T&E program with a revision to the AUR Low Rate Initial Production (LRIP) entrance criteria. Due to this delay, testing of the Tactical Tomahawk Weapon Control System (TTWCS) was expanded to support existing installation schedules of fleet-releasable TTWCS hardware and software.

Differences between Tomahawk Block III and the Tactical Tomahawk Baseline IV in the fuze, significant structural modifications to the Baseline IV missile, and modified terminal engagement parameters potentially affect system lethality and require live fire testing. During FY00-01, the program office carried out substantial modeling and analysis to address live fire concerns. Modeling and simulation efforts failed to fully address two of the three areas of concern. Subsequently, in FY01, a LFT&E strategy was developed and approved that included system-level testing of Tomahawk Baseline IV missiles with live warheads against realistic targets.

## **TEST & EVALUATION ACTIVITY**

There was one completed test event in FY01, OT-IIIIE. This test evaluated TC2S software release TMPC 3.1. Software version TMPC 3.1 introduced the Post-Digital Scene Matching Area Correlator-Global Positioning System (PDGPS) capability. This feature permits the use of the Global Positioning System aiding after the inertial navigation system has received a Digital Scene Matching Area Correlator (DSMAC) update.

Test event OT-IIIF, evaluating TC2S software release TMPC 3.2, was begun in FY01 but has not yet been completed. This software version adds the capability of planning missions with a steeper terminal dive maneuver than previously available. Other enhancements include tools to increase the efficiency and flexibility of the mission planning process.

Test event OT-IIIL, evaluating the Advanced Tomahawk Weapon Control System (ATWCS) version 1.7.1, was also begun in FY01 but has not yet been completed. ATWCS 1.7.1 incorporates expanded functional capability, improvements in management of data communication, improvements to the human-machine interface, and new interfaces to systems external to ATWCS: the Global Command and Control System-Maritime and the Battle Force Tactical Trainer.

No operational test or live fire test activity of Tactical Tomahawk was conducted in FY01.

## **TEST & EVALUATION ASSESSMENT**

The testing conducted during phase OT-IIIIE resulted in findings that TC2S software version TMPC 3.1 is operationally effective and operationally suitable. The software did not meet certain mission-planning timeline requirements, but the user community found the software acceptable despite this shortcoming. Further investigation by DOT&E revealed that the ORD requirements, as written, do not accurately reflect the operational environment and that correction of this discrepancy would remove the apparent deficiencies. DOT&E asked that the Navy take action to address the discrepancy and ensure that interpretations of the requirements are formally documented.

The restructuring of the Tactical Tomahawk T&E program has reduced both the quantity and quality of the information available to the milestone decision authority for the LRIP decisions. Operational testing to support these decisions has been abbreviated. A single engineering test flight replaces an Operational Assessment (OA) in support of the first LRIP increment. The second LRIP increment will be supported by a second engineering test flight, launched from a fixed underwater site plus stand-alone (non-integrated) testing of the TTWCS vice the completed TECHEVAL. The TECHEVAL entails integrated testing of the AUR, TTWCS, and TC2S operating as a system and is supported by four Tactical Tomahawk AUR flight tests launched from surface ships and submarines. A major purpose of TECHEVAL is demonstrating system readiness for OPEVAL (full-scale OT&E in support of full-rate production), whereas an OA provides early feedback of operational considerations to the program. Consequently, the levels of system maturity and system integration seen in an OA are considerably lower than those of TECHEVAL.

The Tactical Tomahawk T&E strategy presents considerable challenges. Successful development of Tactical Tomahawk will add considerable capability and flexibility to the Navy's land attack arsenal. These new capabilities require an unprecedented degree of integration among the segments. The T&E strategy must ensure that the level of integration achieved in testing is representative of the operational environment.



## USMC H-1 UPGRADES



This program combines upgrades of two USMC H-1 aircraft: the AH-1W Cobra attack helicopter and the UH-1N light utility helicopter. The common elements of the two will be identical twin engines, drive trains, a new four-bladed rotor, tail sections, and integrated digital cockpits. In addition, the AH-1 attack helicopter will gain an upgraded targeting system and the UH-1 will have an upgraded night navigation system. The upgrade will extend the lives of the two H-1 models well into the 21st century.

The upgrade of the AH-1W is referred to as the AH-1Z, and the upgrade of the UH-1N is referred to as the UH-1Y. Collectively, the AH-1Z/UH-1Y effort constitutes the USMC H-1 Upgrades Program.

### **BACKGROUND INFORMATION**

The Marine Corps instituted the H-1 Upgrades program in 1996 by combining several lesser planned upgrades to their UH-1 utility and AH-1 attack helicopters. Prior to entry into EMD in September 1996, DOT&E approved the program's TEMP and alternative LFT&E plan, and USD(A&T) approved a waiver from full-up, system-level LFT&E. The AH-1Z will be tested full-up, system-level; the UH-1Y received a waiver from full-up, system-level testing.

The alternative LFT&E plan calls for component and sub-system level testing of critical components for each helicopter. Common components tested as part of the AH-1Z Live Fire tests will not be re-tested as part of the UH-1Y Live Fire testing. The H-1 Upgrades Operational Requirements Documents require that both helicopters be tolerant to impacts by 12.7mm rounds and have crashworthy enhancements. Additionally, the drive components of the AH-1Z should be damage-tolerant to 23mm rounds.

### **TEST & EVALUATION ACTIVITY**

The only OT&E activity during the year was test planning. The approved TEMP calls for the T&E program to be conducted in two phases: integrated contractor/government developmental testing called IT and Operational Testing. Each aircraft model (AH-1Z and UH-1Y) will undergo its own individual OT&E and LFT&E.

To provide feedback early in development, the operational testers have formed a team to monitor IT and to provide Marine maintainers to assist with aircraft maintenance and to validate maintenance documents and procedures. Concurrent with IT, the operational testers will conduct two operational assessments that will provide data to support two LRIP decisions. OT&E for both aircraft will be conducted prior to MS III.

Live Fire testing of critical components and sub-systems continued, with five of the 17 scheduled tests now completed. During this past year, ballistic firings were conducted against the main rotor drive shaft and the 42° gearbox that drives the tail rotor. FY01 tests included dynamic ballistic tests of the 90° gearbox located directly next to the tail rotor.

### **TEST & EVALUATION ASSESSMENT**

An Integrated Test Team (ITT) consisting of government and contractor flight test engineers and pilots is conducting the IT program. The contractor demonstrates safety of flight of the EMD aircraft prior to participation of government personnel in flight testing. Funding constraints continue to threaten the overall scope of testing; recent program upheaval caused by increased costs and poor performance by the avionics integration subcontractor triggered an ongoing review of the program baseline, the outcome of which is not final at this writing. The program Test Integration Working Group (TIWG), in which DOT&E participates, is actively seeking to develop an integrated T&E program that should resolve all critical technical and operational issues before production.

An LFT&E Integrated Product Team (IPT), which includes representatives from DOT&E, the program management activity, the Naval Air Systems Command, and the prime contractor, has been formally established under the TIWG. This group has implemented changes in the component test procedure to ensure that an adequate get-home capability is demonstrated following hits to critical components and is identifying opportunities for a battle damage repair team to participate in the component-level tests as well as the full-up and full-up, system-level live fire testing.

The H-1 Upgrade Program has a comprehensive, robust LFT&E plan that is showing satisfactory progress. The LFT&E program is fully integrated into the systems engineering effort and should yield a reasonable opportunity to incorporate improvements as deficiencies are identified.

## V-22 OSPREY



The V-22 Osprey is a tilt-rotor vertical/short takeoff and landing (VSTOL), multi-mission aircraft developed to fill multi-Service combat operational requirements. The MV-22 will replace the current Marine Corps assault helicopters in the medium lift category (CH-46E and CH-53D). The Air Force requires the CV-22 to provide a long-range VTOL insertion and extraction capability and to supplement the Special Operations Forces MC-130 aircraft. The tilt-rotor design combines the vertical flight capabilities of a helicopter with the speed and range of a turboprop airplane and permits aerial refueling and worldwide self-deployment.

Two 6150 shaft horsepower turboshaft engines drive two 38-ft diameter, 3-bladed proprotors. The proprotors are connected to each other by interconnect shafting which maintains proprotor synchronization and provides single engine power to both proprotors in the event of engine failure. The engines and flight controls are controlled by a triply redundant digital fly-by-wire system.

The airframe is constructed primarily of graphite-reinforced epoxy composite material. The composite structure is intended to provide improved strength to weight ratio, corrosion resistance, and damage tolerance compared to typical metal construction. Battle damage tolerance is built into the aircraft by means of composite construction and redundant/separated flight control, electric and hydraulic systems. An integrated electronic warfare defensive suite including a radar warning receiver, a missile warning set, and a countermeasures dispensing system will be installed.

The ballistic design requirements specify not-to-exceed vulnerable areas for the following threats: 7.62mm API, 12.7mm armor-piercing incendiary (API), 14.5mm API, and 23mm API. Hits could occur at either hover condition or during a 2-g maneuver. Following a hit, the aircraft must be able to complete a 30-minute flight and land vertically.

### **BACKGROUND INFORMATION**

The V-22 is being developed to provide the Marine Corps and Air Force with the capability to conduct assault support and long-range, high-speed missions requiring vertical takeoff and landing capabilities.

Starting with OT-IIA, a total of five periods of OT&E have been conducted. The first three periods of OT&E used test aircraft from the earlier FSD program. The main thrust of these OT&E

periods was ground testing combined with simulation. OT-IID in 1998 was conducted using EMD aircraft numbers 9 and 10, the final two aircraft delivered under the EMD program. OT-IID consisted of 142.6 flight hours conducting operationally realistic missions and the MV-22 was found to be potentially operationally effective and potentially operationally suitable, although unrealistic maintenance procedures and contractor involvement skewed the reliability and maintainability data.

OT-IIIE (OPEVAL) of the MV-22 began on November 2, 1999 and finished on July 21, 2000, accomplishing 804 flight hours in 522 sorties. OPEVAL was conducted with five MV-22 LRIP aircraft, aircraft numbers 11 through 15, aboard four Navy ships and at nine locations ashore. One LRIP aircraft was destroyed, and 19 Marines were killed in April 2000 when the aircraft experienced an excessive rate of descent and entered into an aerodynamic phenomenon called vortex ring state.

A waiver request from full-up, system-level live fire testing for the V-22 was supported by DOT&E and granted by the Secretary of Defense on April 25, 1997. An alternative LFT&E plan, approved by DOT&E prior to submittal of the waiver request, included a comprehensive series of ballistic tests of critical components, major assemblies, and aircraft structures. A continuous process of design refinements has been an integral part of the system engineering effort since the start of live fire testing, and several design changes have been made based on the test results.

The effectiveness of the V-22's vulnerability reduction features was demonstrated during the LFT&E program. Numerous vulnerability reduction features were developed or integrated into the design as a direct result of LFT&E, including re-design of the composite sponson fuel tank structure.

## **TEST & EVALUATION ACTIVITY**

DOT&E completed an independent evaluation of test adequacy, operational effectiveness, suitability and survivability, and submitted the required B-LRIP Report to the Secretary of Defense and congressional defense committees in time to support the Milestone III decision planned by the Navy in November 2000. The Navy delayed the Milestone III decision indefinitely after a second fatal V-22 mishap in December 2000. All V-22 flying was halted following the December 2000 mishap and is not expected to resume until spring 2002.

In the wake of two serious mishaps, the V-22 program has restructured the development and acquisition schedule, seeking advice from several independent sources: a Blue-Ribbon Panel appointed by the Secretary of Defense to review the entire program's history and future; an Executive Committee of senior Service officials; and a panel of aeronautical experts from NASA and academia. In addition, the program has consulted closely with DOT&E as plans for future needed testing were developed.

## **TEST & EVALUATION ASSESSMENT**

In the B-LRIP Report, DOT&E concluded that testing had been adequate to determine the MV-22's operational effectiveness, operational suitability, and survivability. However, additional testing is needed to verify correction of deficiencies, the effectiveness and suitability of waived items, and to investigate the phenomenon of vortex ring state. The MV-22 was assessed by DOT&E as operationally effective but not operationally suitable. Results from OT-IIIE (OPEVAL) indicate that the V-22 will provide major range, speed, and payload improvements to meet Marine Corps and Special Operations Forces requirements. The V-22 offers significant maneuverability and handling advantages as compared to conventional helicopters; e.g., rapid deceleration upon arrival at a landing zone and rapid acceleration

during departure. When tactics are fully developed, these capabilities should provide substantive advantages in mission accomplishment and survivability. In addition, OPEVAL results indicated that with modified operational procedures, at least some required tasks could be performed despite the downwash experienced in the rotary wing mode, which had been an issue of concern in previous OT&E. The MV-22 met all the key performance parameters specified in the Joint Operational Requirements Document.

Operational testing of the MV-22 did not demonstrate that the MV-22 as configured and tested during OPEVAL is operationally suitable. The MV-22 demonstrated marginal mission reliability, excessive maintenance manpower and logistic support requirements and inadequate availability, interoperability, human factors, documentation, and diagnostics capabilities. In the latter half of OPEVAL, the trends on some key measures of suitability were positive, suggesting that the aircraft has the potential to eventually meet its suitability requirements. Nonetheless, taken as a whole or considering only its improved suitability data from the second half of OPEVAL, the MV-22 failed to meet several important JORD established thresholds. Moreover, the demonstrated results for MV-22 mission reliability, maintainability, and availability were less favorable than the same measures from the fielded CH-46 fleet. The OPEVAL results also failed to confirm the improvements postulated before the test in system reliability and fault diagnostics.

The effectiveness of the V-22's vulnerability reduction features was demonstrated during the LFT&E program. Also, the following vulnerability reduction features were developed or integrated into the design as a direct result of LFT&E: redundant jam-proof actuators; run-dry gear boxes; improved composite wing structure and fuel tanks; dual, tandem swashplate actuators; damage-tolerant ballscrew conversion actuators; dry bay fire protection; self-sealing fuel tanks; and suction fuel system.

Early ballistic tests against the full-Scale development aircraft identified a potentially serious cracking problem following a hit into the composite sponson fuel tank structure. The damage was significantly greater than expected and was accompanied by fires under the fuselage floor and within the cargo/passenger area of the fuselage. The sponson structure was re-designed using a different epoxy resin as well as a revised graphite fiber laydown process and re-tested. The additional tests demonstrated that the cracking was significantly reduced, there were no fires, and repair was within the limits typically used for composite structures.

The general approach to return the V-22 to flight is staged, with high rate of descent (HROD) testing the first order of business after a thorough ground test of the flight control software in laboratories and simulators. As soon as the first aircraft is modified with system safety changes, developmental flight testing will resume; an Operational Assessment will be done in conjunction with early DT&E. After confirmation of the safe flight envelope in the HROD tests, the Navy plans to issue a limited flight clearance to operational V-22 units, which will allow training flights to prepare for a second phase of OPEVAL to address the issues raised in the B-LRIP Report (testing not conducted, waived items, and correction of deficiencies). DOT&E plans to issue a supplement to the B-LRIP Report containing our assessment of test results.

## **LESSONS LEARNED**

The restructuring of the V-22 program, which has substantially delayed getting the V-22 to operational units, was necessary and prudent. The extended development and deficiency correction plans are cautious and appropriate.

This Page Is Intentionally Left Blank

## VIRGINIA (SSN 774) CLASS ATTACK SUBMARINE



*Virginia* will replace the aging fleet of *Los Angeles* (SSN 688) Class submarines. It is intended to be a submarine comparable in most respects to its immediate predecessor, the *Seawolf* but in a more affordable configuration. It is designed to rapidly deploy to militarily important hostile ocean areas and deny their use to the enemy, clear the way for strikes by other friendly forces, and engage and destroy enemy submarines, surface forces, and land targets. *Virginia* will have a broad range of missions packaged in a quiet, heavily armed, survivable submarine. These include Covert Strike Warfare, Anti-Submarine Warfare, Covert Intelligence Collection/Surveillance, Covert Indication and Warning and Electronic Warfare, Anti-Surface Ship Warfare, Special Warfare, Covert Mine Warfare, and Battle Group Support.

*Virginia* is required to be capable of targeting, controlling and launching MK 48 ADCAP torpedoes, mines, and Tomahawk missiles from anywhere in the ocean. Its sonar capability is expected to be similar to *Seawolf*'s, and its electronic support suite and combat control system represent improvements over legacy systems. The external communications system is required to be an improvement over *Seawolf* and legacy systems, providing full, high data rate interoperability with U.S. and allied forces. These characteristics provide intelligence and strike capabilities.

### **BACKGROUND INFORMATION**

The Milestone I DAB approved *Virginia* to enter Phase I in August 1994. To support Milestone II, a thorough Early Operational Assessment of *Virginia* was conducted, concluding that *Virginia* was potentially operationally effective. The Milestone II DAB approved *Virginia* to enter Phase II in June 1995.

The *Virginia* sonar program, known as AN/BQQ-10 Acoustic Rapid COTS Insertion (A-RCI), uses COTS technology to upgrade submarine sonars. Current upgrades are for the SSN 688 class submarines, and will later include *Trident* SSBNs, *Seawolf*, and *Virginia*. After Phases III and IV operational tests are completed in FY02, the A-RCI program will continue to upgrade its sonars through (approximately annual) software and/or hardware upgrades. The AN/BQQ-10 series sonar is planned to progress to a common COTS architecture for all U.S. submarine sonars by 2005-2007.

DOT&E recommended, and the Secretary of Defense approved, a waiver from full-up, system-level live fire testing of *Virginia* in accordance with Title 10, Section 2366. DOT&E approved the

alternative LFT&E plan submitted in lieu of full-up, system-level testing in June 1995. This plan includes shock qualification tests and analysis of components, surrogate underwater shock tests, a Total Ship Survivability Trial (TSST), a Full Ship Shock Trial, as well as a series of vulnerability assessments.

## **TEST & EVALUATION ACTIVITY**

Revision C of the TEMP was signed in March 2001. Because the test program extends so far into the future, DOT&E directed that the TEMP must be updated in FY03 before the scheduled Dockside and Builder's Trials begin to address: (1) any performance shortfalls and associated corrective actions from testing encountered prior to sea trials; (2) changes needed to the test scenarios to reflect updated threat information; (3) lessons learned from *Seawolf* and BSY-2 operational testing; and (4) testing from the *Virginia* lead ship pre-planned product improvements, including follow-on technology insertions.

This TEMP revision includes a move of the Full Ship Shock Test (FSST) and Total Ship Survivability Trial (TSST) from Hull 1 (SSN 774) to Hull 2 (SSN775), which DOT&E agreed to, based on the Navy's input that this move would improve overall scheduling stability without impacting the Milestone III decision. Both SSN 774 and 775 will be used for TECHEVAL/OPEVAL. It also added a Critical Operational Issue to address Information Assurance. The TEMP update also revised several Critical Technical Parameters (CTP's) and developed CTPs on Compatibility, Interoperability and Integration.

In August 2001, DOT&E approved the concept of testing by OPTEVFOR at the Command and Control System Module (CCSM) Off-hull Assembly and Test Site or COATS facility. The COATS land-based operational test (OT-IIB) is proposed to assess the potential operational effectiveness and suitability of the *Virginia*-class SSN combat system. The basic test plan involves the use of the On-Board Team Trainer and simulation/stimulation (SIM/STIM) systems to create scenarios that will allow for the examination of combat system integration.

Technical testing to improve the acoustic performance of the *Virginia* propulsor development continued throughout the year. The *Virginia* program has opted for a different propulsor design than that used on the *Seawolf* class, hoping to take advantage of hydro-acoustical and propulsor technological advances evolved since the original *Seawolf* design. More details are in the classified report.

The third and final *Virginia* class Operational Assessment (OA) by COMOPTEVFOR was completed in December 2001. The latest OA (which ended for data gathering on September 2001) will not have the latest propulsor results. The latest propulsor data will be evaluated by OPTEVFOR along with the results of the COATS testing in Spring 2002.

The Navy continued its vulnerability assessment work and prepared Update II of the Vulnerability Assessment Report (VAR), which was completed in July 2001. DOT&E is reviewing this new VAR Update and will provide comments to the Navy. DOT&E has continued to participate in *Virginia* LFT&E Senior Working Group meetings and TSST Planning Group meetings to reach resolution of earlier VAR comments, participate in TSST planning, and provide insight as well as oversight on Navy plans for other planned LFT&E activities. DOT&E also continued to witness component shock qualification tests, and review with the Navy the results of completed Live Fire component and surrogate tests. As with *Seawolf*, there is a deficiency in the LFT&E plan for *Virginia* regarding survivability data in the propulsion system. The Director, Naval Nuclear Propulsion Systems



and DOT&E have engaged to draft a memorandum of agreement that provides sufficient information for DOT&E to perform its statutory requirement to assess the survivability of the entire ship.

### **TEST & EVALUATION ASSESSMENT**

An FY97 OA concluded that the *Virginia* design should lead to a potentially operationally effective submarine. The OA identified three high and six moderate risk areas. Many of the issues identified during the FY97 OA were the results of programmatic decisions to scope back efforts or eliminate capabilities factored into the original estimates of the *Virginia* performance baseline.

The Navy has evaluated six damage scenarios for the detail design VAR using linear extrapolation from physics-based design-level shock analyses in local environments to 10 percent above the design level. The assessment at this level of shock intensity resulted in very limited damage and few lessons learned. The Navy is proposing a “Meaningful Drill Concept” for the post-delivery TSST with damage scenarios that are to be tied back to the six shot lines. DOT&E has questions about how the Navy will simulate realistic propulsion plant damage in the TSST scenarios. DOT&E is continuing to work with the Navy to resolve these issues.

DOT&E has other LFT&E concerns: (1) the approach for Verification, Validation, and Accreditation (VV&A) of LFT&E computer models has not been described; (2) the extrapolated Ship Shock Test results to higher shock intensity levels for use in the assessment of *Virginia*’s vulnerability to underwater shock has not been described; and (3) *Virginia*’s ability to surface after exposure to an underwater burst at the hull integrity shock factor level may not be assessed.

This Page Is Intentionally Left Blank

# **PART V**

## **AIR FORCE PROGRAMS**



# **ADVANCED EXTREMELY HIGH FREQUENCY (AEHF) SATELLITE COMMUNICATIONS SYSTEM**

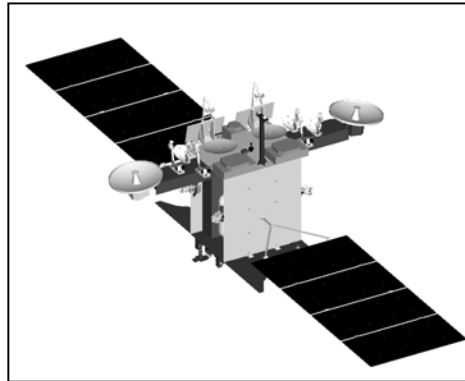

The Advanced Extremely High Frequency (AEHF) satellite communications (SATCOM) system is designed to provide secure, survivable communications to the U.S. warfighters during all levels of conflict. It will follow Milstar as the protected backbone of DoD's Military Satellite Communications (MILSATCOM) architecture.

## **BACKGROUND INFORMATION**

In lieu of an additional Milstar satellite to replace Flight 3 (which placed the satellite in a nonoperational orbit), the first flight of the Advanced EHF satellite program, named Pathfinder, will be programmed to operate initially as a Milstar II satellite. The second flight will then be launched as a fully capable Advanced EHF satellite. After it is operational, Pathfinder will be reprogrammed on-orbit as an Advanced EHF satellite.

The first three program phases, Advanced EHF Technology, Engineering Models, and System Definition, have been completed. At Milestone B, the DAB authorized fabrication and assembly of the first two satellites (SV1, SV2), development and deployment of the ground command and control segment, and advanced procurement for three additional satellites (SV3, SV4, SV5) within the FYDP. A separate tailored Milestone C is anticipated at the end of FY03, following completion of the system-level Critical Design Review to provide final authorization for production of SV3, SV4 and SV5. The first launch is scheduled for 3QFY06 and the second launch for 3QFY07. The newly approved acquisition strategy provides for a three-year delay before the third launch. The launch of the last three satellites, SV3, SV4 and SV5, will be 2QFY10, 1QFY11, and 3QFY11, respectively.

## **TEST & EVALUATION ACTIVITY**

AFOTEC performed an Early Operational Assessment (EOA) and Operational Impact Assessment (OIA) in support of the Milestone B decision in 4QFY01. In addition, an Operational Assessment (OA) will look at the results of the DT/OT performed on the Pathfinder satellite to verify its full capability to function as a Milstar II LDR/MDR satellite.

MOT&E will evaluate whether or not the entire system, including equipment, personnel, procedures, training, and logistics support, is effective and suitable based on the operational requirements. The test will exercise satellite-to-satellite cross-links to evaluate theater-to-theater communications, network control, satellite control, and interoperability.

## **TEST & EVALUATION ASSESSMENT**

AFOTEC performed an EOA and OIA based on results of the engineering model tests, the contractor system design review presentation, modeling and simulation, and a review of program documents. Satisfactory progress is being made on the four major technology risk areas: nuclear hardening and shielding, performance of the nuller spot beam, performance of the phased array antenna, and electric propulsion. The contractor should minimize the use of turbo coding because of its susceptibility to nuclear fading.

The lack of terminal synchronization is both a void in the program and a risk to successful MOT&E. The following risks to the test program were identified: pressure to reduce the minimum developmental testing as defined in the TEMP, insufficient software testing, the need for a payload simulator that is common for all the terminal development programs, and availability of Pathfinder for MOT&E after it has become an operational asset.

It is imperative to monitor the fidelity of the AUST-T terminal simulator and the payload simulators. If their configurations do not remain standardized and consistent with the true payload, the new terminals will not be compatible with the payload or with each other.

## AIM-120 AMRAAM

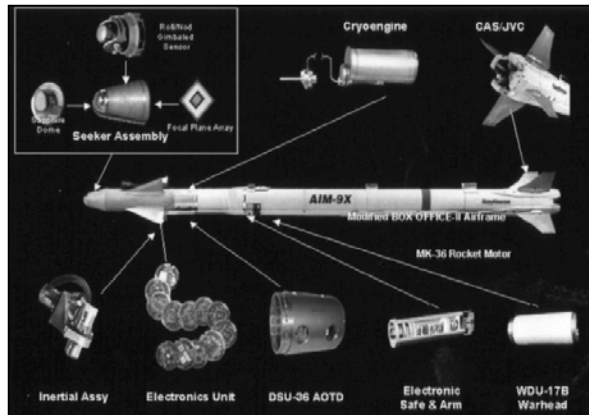

AIM-120 is an all weather, radar guided, air-to-air missile with launch-and-leave capability in both the beyond-visual-range and within-visual-range arenas, enabling a single aircraft to simultaneously engage multiple targets with multiple missiles. The U.S. Air Force and Navy, as well as several foreign military forces use the AIM-120. Currently employed by the F-15C, F-15E, F-16, and F/A-18C/D, AIM-120 will also be employed by the F/A-18E/F, F-22, and the Joint Strike Fighter.

The AIM-120C was developed to reduce its box size from 17.4 to 12.5 inches. This allowed for increased internal carriage in the F-22. Lethality improvements are being incorporated into the missile from Lot 8 and beyond, culminating in a new warhead in Lot 11 and lengthened rocket motor in Lot 12. All current U.S. deliveries are of the AIM-120C configuration.

The AMRAAM Pre-Planned Product Improvement (P3I) Phase 3 development program is underway. The Phase 3 missile will include new guidance section hardware and software. The antenna, receiver, and signal processing portions of the system are being upgraded to handle the requirements to counter new threats, and will be compressed to create room for future growth. Some existing software will be re-hosted to a new Higher Order Language (C++), some existing software will be re-hosted and modified to function with the new hardware, and some additional software algorithms are being written to react to the new Phase 3 threats.

### **BACKGROUND INFORMATION**

The AMRAAM program entered FSD in September 1982 and entered full-rate production (Milestone III) in April 1992. FOT&Es were completed in May 1993 and December 1995. This testing included the launch of 40 missiles under various test conditions and continued the captive-carry reliability program (CCRP) testing. Twenty-four of the live launches were missiles from CCRP inventory. The live shots were designed to evaluate missile end game performance against advanced ECM threats and warhead lethality in more challenging end game scenarios.

Another FOT&E was started in 1996. This was a joint Air Force and Navy evaluation emphasizing testing of lethality improvements in missiles from Lot 8 and higher, culminating with the new warhead in Lot 11 and rocket motor in Lot 12. The LFT&E program for the new warhead included

characterization of the new contact fuze and arena testing of the warhead. Arena tests were conducted against a cruise missile, a bomber section, and two foreign fighter targets in 1996 and 1999.

### **TEST & EVALUATION ACTIVITY**

The TEMP is under revision to provide a comprehensive developmental and operational test and evaluation for the AMRAAM (P<sup>3</sup>I) Phase 3 Program. This missile is scheduled to begin production in Lot 16 (FY04) and will incorporate new seeker and guidance sections as well as Operational Flight Program software written in a new language. Raytheon plans thirty-eight captive carry missions and eight DT&E missile launches. Based on current system reliability exceeding the ORD requirement and a decision to rely on contractor controls over production, including reliability acceptance testing and environmental stress screening, no captive carry reliability program is planned. An OT&E will follow using the first Phase 3 production missiles. The Air Force's Air Combat Command and Navy's Air Test and Evaluation Squadron will conduct the test under AFOTEC and COMOPTEVFOR oversight. Significant attention has been given to the process for accrediting modeling and simulation for use in the OT&E. DOT&E highlighted concerns with the model and its use in OT&E to the program staff and the operational test agencies. Technical issues remain and final scoping of the OT&E awaits resolution of these issues. The TEMP has been submitted to OSD for approval.

### **TEST & EVALUATION ASSESSMENT**

The Phase 3 P3I missile is largely a new missile with distinct capabilities from predecessor variants of the AIM-120. Hardware and software changes in the guidance section are significant. An adequate OT&E strategy to assess performance of these upgrades against requirements is evolving. At present, the Air Force and Navy jointly propose nine OT&E live fire events and a constructive model and simulation adapted from the baseline AMRAAM program. DOT&E is evaluating the proposal as presented in the draft TEMP. Adequate model components, overall operational test adequacy, and a determination that ORD required capability is tested are open issues that require resolution for TEMP approval. A potential outcome is additional cost to add characteristics to the modeling and simulation program and/or additional missile shots for OT&E.

DOT&E has completed its independent evaluation of AMRAAM LFT&E results. The Director plans to send his report to Congress in late 2001. Based on the results of three arena tests, one flight test, and other tests and simulation analyses, DOT&E found that the P3I warhead is lethal against its expected targets and that it is as lethal or more lethal than the baseline AMRAAM warhead. DOT&E also found that the AMRAAM P3I LFT&E program was adequate to evaluate the system's lethality.



## AIR FORCE MISSION SUPPORT SYSTEM (AFMSS)



**MPS III**

**PFPS**

The Air Force Mission Support System (AFMSS) is a family of hardware and software products designed to provide automated mission planning support for Air Force aircraft and precision-guided munitions (PGMs).

AFMSS planning systems use several configurations comprised of commercial off-the-shelf (COTS) hardware to meet system requirements. Two basic configurations exist: the Mission Planning System (MPS), which is UNIX-based and runs on UNIX workstations and the Portable Flight Planning Software (PFPS), which is Microsoft Windows-based and runs on IBM-compatible PCs. Upgrades for AFMSS are developed in an evolutionary or spiral development process.

Used in conjunction with AFMSS, mission-planning environments (MPEs), consisting of Aircraft/Weapon/Electronics (A/W/E) modules and other Installable Software Modules (ISMs), produce aircraft-specific combat mission folders, consisting of maps, images, and flight information forms. Additionally, aircraft with electronic data transfer capability can employ aircraft-unique hardware peripherals with AFMSS to prepare data transfer devices (DTDs) for uploading mission information into aircraft computers.

There are currently four Mission Planning System (MPS) hardware configurations. Eventually, all Air Force AFMSS users and Navy platforms using legacy mission planners will migrate to the Joint Mission Planning System (JMPS) architecture. JMPS is described in a separate report in this document.

### **BACKGROUND INFORMATION**

In earlier years, the UNIX-based AFMSS was a problematic, trouble-plagued program. While some versions worked acceptably (albeit with many workarounds), the more demanding UNIX-based versions were not operationally effective or suitable, particularly in earlier versions. Recent AFMSS versions (both UNIX and PFPS) have improved considerably. All Air Force users are now able to meet operational commitments using AFMSS planning systems.

Current activity in the AFMSS program is directed toward development, testing, and fielding of planned, periodic software releases. The goals of these releases are to correct deficiencies remaining from earlier versions and to add functionality, consistent with user requirements and upgrades to aircraft operational flight programs.

**TEST & EVALUATION ACTIVITY**

Table 1 below summarizes AFMSS operational test activity performed during FY01.

**Table 1. Summary of Recent AFMSS OT&E Activity**

Operational Test Organization	MPS Versions Tested	PFPS Versions Tested
28 <sup>th</sup> Test Squadron, Air Warfare Center (AWFC), Eglin AFB, Florida	F-15 Multi-Stage Improvement Program (MSIP), F-15E Suite 3.1 with EGBU-15, F-15E Suite 4.0, F-16 PO6 (40T6/50T5)	PFPS 3.1.2 (basic), F-16 Software Capabilities Upgrade (SCU) 4/4.1, F-16 PO6 (40T6/50T5) Cartridge Support Software (CSS), E-3A
Detachment 1, 53 <sup>rd</sup> Test and Evaluation Group (TEG), Holloman AFB, New Mexico	F-117A	
9 <sup>th</sup> Wing, Beale AFB, California	U-2	
18 <sup>th</sup> Flight Test Squadron, Air Force Special Operations Command (AFSOC), Hurlburt Field, Florida		PFPS 3.1.1 (basic), C-130 (various designations)
33 <sup>rd</sup> Flight Test Squadron, Air Mobility Warfare Center (AMWC), Fort Dix, New Jersey		C17, C-5, KC-10, KC-135

Operational tests of planning systems utilize mission planning scenarios characteristic of squadron or wing level peacetime and combat missions. Missions were planned under realistic conditions and time constraints while test team members tracked failure data, evaluated software maturity, and recorded the time required to prepare mission planning products.

**TEST & EVALUATION ASSESSMENT**

The AFMSS family of systems has matured over the past few years to provide effective mission planning tools for Air Force aircraft. All AFMSS planning systems that underwent operational testing in FY01 received overall satisfactory ratings, except for the F-117A version 6.0, which received a marginally satisfactory rating because of software and hardware reliability problems discovered during testing. Several users still have some functional areas that are rated as unsatisfactory or marginally satisfactory, but overall speed improvements of the hardware makes these problems bearable for the user. Although many deficiencies remain uncorrected, most of the outstanding deficiencies are considered minor and of low priority.

Although funding to migrate platforms currently on MPS and PFPS systems to JMPS has been budgeted, the current legacy systems must continue to be maintained and updated for the foreseeable future through at least FY09. Platform migration is schedule to begin in FY 04 and be complete in FY09. This will mandate continued operational tests to ensure evolving versions continue to meet requirements.

## AIRBORNE LASER (ABL)



The Airborne Laser (ABL) is intended to shoot down enemy Theater Ballistic Missiles (TBMs) during their boost phase of flight. The ABL engagement concept calls for the laser to focus on a missile's booster skin, rupturing it or damaging it sufficiently to cause the missile to lose thrust or flight control and fall short of its intended target. The ABL engagement of TBMs in the boost phase should result in the negation of the missile before decoys, warheads, or submunitions are deployed.

ABL is designed to be rapidly deployable and add a boost-phase layer to the Theater Missile Defense (TMD) capability. It will be positioned behind the forward line of friendly troops and moved closer toward enemy airspace as local air superiority is attained. The Air Force is proposing a seven-aircraft fleet and envisions that five aircraft would deploy to support two 24-hour combat air patrols in a theater.

The aircraft will be a modified Boeing 747-400F (freighter), carrying a megawatt-class Chemical Oxygen Iodine Laser (COIL) operating in the near infrared (1.315 microns). In addition to the laser, the ABL system will also have a Beam-Control/Fire-Control (BC/FC) system and a Battle Management, Command, Control, Communications, Computers, and Intelligence (BMC4I) system. The BMC4I system will provide autonomous capability to detect and track the target and manage much of the engagement. A passive IR sensor suite will provide boosting TBM detection capability, and an active laser ranger system provides precise ranging and angular pointing. After a target has been acquired, the BC/FC system will actively track the missile and use adaptive optics to compensate for the degrading effects of atmospheric turbulence on the laser beam's path. Once the BC/FC system has established a track, the high-energy laser will irradiate the missile until it has been negated.

### **BACKGROUND INFORMATION**

The program passed Milestone I and entered the Program Definition and Risk Reduction (PDRR) phase in November 1996. During the PDRR phase, one ABL system will be built to demonstrate the feasibility of the system. The high-energy laser on the PDRR system will have about half the energy of the full production-representative system, and a number of the other subsystems will also not be production-representative.

There are several interim milestones during PDRR. AFOTEC completed EOA-1 in May 1998 to support the Authority to Proceed (ATP-1) decision in June 1998. Overall, EOA-1 found the ABL

program and system design were on track at that early stage of the PDRR phase. The team did not assess potential operational effectiveness and suitability because of the lack of performance data on flight-representative hardware and software. The ATP-1 decision allowed the Air Force to commit to the purchase of the commercial 747-400F, which will be used for the PDRR system. As currently planned, an ATP-2 review is scheduled for late FY02. This review will authorize the long-lead purchase of the EMD aircraft. Current ATP-2 criteria are (1) performance of the integrated PDRR beam control system at low power; (2) multi-module operation of the PDRR laser modules; and (3) an integrated surveillance system performance.

The program took delivery of the PDRR aircraft from Boeing's commercial assembly line in January 2000, and modifications began that same month at Boeing's Wichita plant. A system-level critical design review was held in April 2000. The aircraft begins ground testing in November 2001, in Wichita, and is scheduled for first flight in January 2002. In FY01, the Tracking Illumination Laser (TILL) and the flight weighted, high-energy laser module both demonstrated initial lasing capabilities. Fiscal Year 2001 was very turbulent for the ABL program. The program was underfunded and ran out of money in March 01, although the contractor team continued to work at risk. This problem was resolved in September when supplemental funding was received. The Department decided to transfer management of ABL from the USAF to BMDO, effective October 2001.

### **TEST & EVALUATION ACTIVITY**

Much progress was made on the MS I TEMP update during this period, but finalization was hampered due to program changes resulting from budget cuts and program restructuring. The System Program Office is planning to finish this update and submit the TEMP to OSD in early FY02.

Laser development and testing have continued and contributed to the final laser-module design for the PDRR aircraft. Several experiments were conducted by the Air Force Research Laboratory (AFRL) to measure fundamental thermodynamic and optical properties of relevant materials, including a number of potential countermeasures and threat target vulnerabilities. Critical components and sub-systems have been investigated under simulated flight and propulsive conditions to gain a better understanding of the internal operating condition of an in-flight missile.

In support of the ATP-2 decision, the 12-month EOA-2 was started in July 2001 by AFOTEC. EOA-2 will address potential operational effectiveness and suitability, potential operational impacts, programmatic issues, requirements, and program support for OT&E. EOA-2 will obtain data from a variety of events and activities, including aircraft/BMC4I ground and flight tests; laser development, tests, and integration; and BC/FC integration and ground tests.

### **TEST & EVALUATION ASSESSMENT**

Overall, the PDRR program contains reasonable amounts and types of tests, but the schedule is ambitious and clearly success-oriented. Although the proposed EMD schedule has increased from 2 to 4 years since last report, ABL remains a high-technical risk program, and the aggressive schedule allows for no significant problems or test failures. The abbreviated EMD phase was originally justified because the PDRR and EMD systems were assumed to be scalable, identical except for the number of laser modules and weight reduction of basic module design. However, the PDRR and EMD designs are beginning to differ more significantly, and further design changes may be required in the future. The

current EMD plan may result in a high degree of concurrency between the PDRR and EMD phases, which would increase risk, and might not provide adequate time to transfer all lessons learned during PDRR testing into the EMD design. When compared to other major acquisition programs that are less complex, the 4-year EMD program is relatively short.

There will be significant challenges involved in adequately testing and evaluating ABL. Specific concerns include the following:

- It will be difficult to test the ABL against an appropriate mix of threat targets the ABL is required to negate. The ABL System Threat Assessment Report (STAR) lists approximately 30 threats that the ABL is required to negate. These missiles include a diverse range of physical and operating characteristics. However, of the various combinations of physical and operating characteristics, it is unlikely that more than one or two of these missile types will be available for testing, and it is unclear how the program will demonstrate effectiveness against the array of different threat missile types. The Live Fire Test and Evaluation (LFT&E) lethality strategy must address targets that will not be included in the flight test program.
- It may be difficult and/or cost prohibitive to perform end-to-end operational tests that cover all of the important parameters of the ABL operating environment. These parameters include range, level of turbulence, azimuth and elevation angles, day and night engagements, and the presence of clouds and other atmospheric conditions.
- Likely countermeasures that reduce ABL's effectiveness need to be identified and included in ABL's test and evaluation program.
- The ABL survivability must be addressed. Early understanding of the threats to the ABL system and ABL system vulnerabilities will be crucial for development of an executable LFT&E strategy for survivability.
- Producing a system that is operationally suitable will be a challenge. The ABL system will have new and unique maintenance requirements compared to other airborne military systems. Thus, adequately assessing the reliability, maintainability, availability, safety, and the required logistics support of the ABL in operationally realistic conditions is an important part of the OT&E.

This Page Is Intentionally Left Blank

## B-1B CONVENTIONAL MISSION UPGRADE PROGRAM (CMUP)



The B-1B Lancer is a swing-wing, heavy bomber, with a takeoff weight of 477,000 pounds and a crew of four. The aircraft has four F-101-GE-102 turbofan engines with afterburners. With air refueling, the B-1B can deliver approximately 50,000 pounds of bombs or near-precision guided weapons to targets anywhere in the world. The aircraft is capable of penetration speeds up to Mach 1.2.

IOT&E of the B-1B was conducted from 1984 through 1989, and it achieved IOC as a nuclear bomber in FY87. With the transition of the B-1B from a nuclear to a conventional role in 1993, the Conventional Mission Upgrade Program (CMUP) was begun. Initially, for a conventional mission, the bomber could carry only Mk-82 500-pound general-purpose bombs. To date, block changes carried out under the CMUP have upgraded the aircraft's capabilities as follows:

- Software upgrades to offensive and defensive systems (Block B).
- Capability to deliver CBU-87/89/97 cluster bombs (Block C).
- Communications system upgrades, addition of Global Positioning System (GPS) navigation, and capability to deliver GBU-31 Joint Direct Attack Munition (JDAM) (Block D).

Remaining blocks of CMUP will accomplish the following:

- Upgrade the computers for increased weapon flexibility and better supportability, and integrate Wind Corrected Munition Dispenser (WCMD), Joint Stand-Off Weapon (JSOW), and the Joint Air-to-Surface Standoff Missile (JASSM) weapons (Block E).
- Upgrade the defensive avionics suite by removing most of the existing AN/ALQ-161 and replacing it with an AN/ALR-56M radar warning receiver and portions of the Navy's AN/ALQ-214 Integrated Defensive Electronic Countermeasures (IDECM) system with a fiber-optic towed decoy (Block F).

CMUP changes to the B-1B enhance conventional weapons delivery capabilities, provide increased situational awareness, increase survivability, and improve supportability. These improvements will equip the B-1B to provide precision strike, attacking strategic and tactical targets at all stages of conflict.

## **BACKGROUND INFORMATION**

Development of Blocks E and F was initiated in FY96. When begun, Block E was expected to be ready for full-rate production (FRP) in FY01 and Block F in FY02. Problems with development of flight software have delayed both Blocks. Block E and F's FRP dates are now in FY03 and FY04, respectively.

Block E adopted a three-phase approach to minimize impacts of software development delays. The first phase (Phase A) has been delivered and tested. This phase supports basic aircraft flight functions of navigation, terrain following, and radar operation. Phase B software will support gravity weapon delivery and Phase C will support guided weapon delivery.

In addition to late flight software, Block F was also impacted by development problems in the Navy's IDECM program resulting in the late delivery of IDECM hardware and software to the B-1B program. Block F FRP is currently projected to occur in March 2004.

Both blocks were re-baselined for cost and schedule in FY99. However, further delays have occurred since that time due to the February 2000 Seattle earthquake and limited test infrastructure to support defensive testing. Because of changes and schedule delays in the programs, the Block E TEMP Annex was approved September 2001 and the Block F TEMP Annex is being updated.

Live Fire Test & Evaluation (LFT&E) of Block D consisted of a series of LFT ballistic tests conducted on large assemblies cut from production aircraft #1. All ballistic testing was completed to support Block D MS III. An LFT&E report was submitted to Congress in January 1999. LFT&E will be evaluated by analysis for Block E and Block F.

## **TEST & EVALUATION ACTIVITY**

DT&E flight testing of Block E began in December 2000 at Edwards AFB, California. Testing to date has concentrated on Phase A (basic aircraft software) and Phase B (capabilities to deliver gravity weapons). As of September 2001, more than 60 Phase A, B, and C flight test sorties have been flown, accumulating more than 250 flight hours on the test aircraft. DT&E flight testing of Phase C functions related to delivery of precision guided munitions started in September 2001 and is planned to be completed by April 2002. Of nearly 1,300 planned test points, more than 56 percent have been completed. Dedicated IOT&E is planned for June 2002 through September 2002.

DT&E testing of the Block F defensive system has included hardware-in-the-loop (HITL) testing at the Nevada Test and Training Range (NTTR), system integration laboratory testing at the Integrated Facility for Avionics Systems Testing (IFAST), and aircraft installed systems testing at the Benefield Anechoic Facility (BAF) at Edwards AFB, California. Block F DT&E flight testing began in August 2001 and is expected to last until December 2002. Early testing will evaluate aerodynamic aspects of deploying the IDECM fiber-optic towed decoy from the aircraft; tests to evaluate situational awareness and jamming effectiveness will follow. Dedicated Block F IOT&E is currently planned for February 2003 to September 2003.

AFOTEC Detachment 5 at Edwards AFB, California, is currently conducting Operational Assessments of Block E and Block F. Aeronautical Systems Center at Wright-Patterson AFB, Ohio, is



currently conducting analyses to support LFT&E of Block E and Block F, leveraging on the previously conducted LFT&E on Block D.

## **TEST & EVALUATION ASSESSMENT**

### **BLOCK E**

Block E DT flight testing of Phase A software has progressed satisfactorily to date. Tests of computer and software functions for basic aircraft flight conditions have revealed relatively few anomalies, and the software appears to be stable.

Testing of Phase B software (gravity weapon delivery functions) is in early stages. To date, the most serious findings have been associated with WCMD releases. WCMDs released from all bays have experienced violent pitch downs and inconsistent tail fin deployments. Test results indicate an inconsistent capability for WCMD to reach the desired target. Store separation testing halted in Phase B. Issues included uncertainties with weapon specific hardware and system aerodynamic effects on weapon release. This could lead to some restrictions on the WCMD delivery envelope. Stores separations are not necessarily dependent on the software build so they can be accomplished in Phase C.

Additionally, as reported last year, there is a high level of risk associated with planned Block E IOT&E in the adequacy of the design of cockpit controls and displays to support weapon delivery from the aircraft. Concerns about the Block E design were based on crew assessments in simulations. Simulator study results and crew subjective opinions indicate that the planned display of Launch Acceptability Regions (LAR) may not provide adequate steering cues to enable flying the aircraft to the correct weapon release zone when the aircraft is not on the planned route or when operators experience heavy workload. Until testing of Phase C software is complete (functions for guided munition weapon delivery), the seriousness of this problem remains unknown. The System Program Office and Air Combat Command are currently working near and far term situational awareness upgrades to address this problem in additional efforts.

Air Combat Command's agreement to furnish a production-representative kitproof aircraft to participate in the planned IOT&E mitigated concern about the adequacy and availability of flight test aircraft.

At least four regression testing sorties are planned at the end of IOT&E to mitigate the risk associated with late delivery of the production version SP-103A aircraft computer and ensure no degradation with the final producible design.

### **BLOCK F**

The Block F development schedule continued to experience delays, in part because of delays in the Navy's IDECM program, but also because of delays in Block E avionics software development. The IDECM fiber-optic towed decoy, towline, and deployment design are high-risk issues for the B-1B, even though the B-1B's environment may be somewhat less stressful than the F/A-18s. Availability of IDECM is on the critical path to Block F flight testing.

## **BOTH BLOCKS (E AND F)**

Flight testing of both Blocks E and F depends on access to the NTTR. Because of competition from other programs and unexpected delays in the availability of key range emitters, the B-1B may have difficulty getting the required number of range sorties in the planned timeframe. Although some sorties can be flown at other test ranges (i.e., China Lake), there remains a risk that range availability could lead to an extension of B-1B flight testing for both upgrades.

Both Blocks E and F of the B-1B CMUP have several moderate to high-risk problems, outlined above, that could prevent or delay meeting operational effectiveness and suitability requirements. Although the risks are diminishing as DT&E is progressing, continued management attention will be necessary to solve technical problems, correct deficiencies, and conduct thorough testing of CMUP functions.

Updated OT&E plans for B-1B Blocks E and F are in work to reflect schedule changes. However, the previously approved test approaches are not expected to change significantly.

## **B-2 SPIRIT**

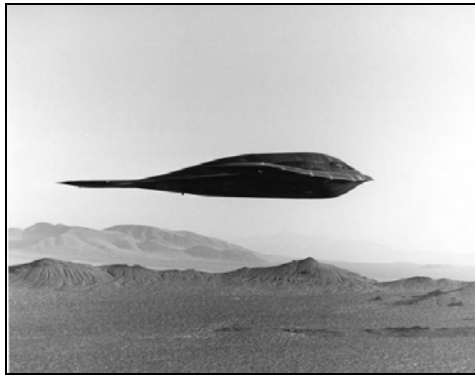

The B-2 Spirit is a land-based, long-range bomber capable of delivering both conventional and nuclear munitions. The aircraft features a flying wing design and incorporates advanced technology to reduce its radar observability and its infrared (IR) signature. The crew consists of two pilots, one of whom serves as the mission commander. The aircraft's characteristics include four engines and two side-by-side weapon bays.

The B-2's most notable design feature is its low radar cross section (RCS), achieved by a combination of shaping and application of surface treatments, including sealants used to fill gaps between panels, adhesives, and tapes to cover the joints.

B-2s from the Main Operating Base were employed in combat during Operation Allied Force (OAF) in 1999, delivering Joint Direct Attack Munitions (JDAMs) against targets in Serbia and Kosovo.

### **BACKGROUND INFORMATION**

The B-2 IOT&E concluded in June 1997. However, the aircraft did not fully meet operational requirements at the conclusion of IOT&E. Principal deficiencies included:

- Defensive Management System (DMS) – inaccurate information, cluttered display and excessive workload to operate.
- Low Observable (LO) Systems – low reliability and poor maintainability.
- Terrain Following/Terrain Avoidance (TF/TA) – potential radar blind spots in turns.
- Mission Capable Rate and Sortie Generation Rate – did not meet operational requirements.
- Deployability – shelter protection required for LO maintenance and protection from rain intrusion; extensive support equipment required.

The B-2 development program has initiated a series of upgrades aimed in part toward correcting the above deficiencies discovered in earlier testing. Significant upgrades that have progressed into development testing (DT) include:

- Upgraded aircraft software through version P2 – improved TF/TA and DMS performance, but some issues remain.
- Alternate High Frequency Materials (AHFM) – improved LO materials, substitutes magnetic radar absorbing material (MAGRAM) in lieu of caulk and tape.
- Joint Air-to-Surface Standoff Missile (JASSM) – hardware and software provisions to support delivery.
- UHF Satellite Communications (SATCOM) – improves interoperability with other force assets.

Additional upgrades have been initiated but are not yet ready for DT&E. These initiatives include:

- Additional LO improvements and diagnostic tools (Various dates).
- 500-pound JDAM – capability to carry and release 80 GPS-guided weapons (DT&E in FY03).
- Enhanced Guided Bomb Unit (EGBU)-28 – replaces GBU-37 (DT&E in FY03).
- Link 16, Center Instrument Display and In-Flight Replanner – improves battlefield situational awareness (DT&E in FY04).
- EHF SATCOM – adds nuclear survivable SATCOM capability (DT&E in FY05/06).
- DOT&E placed the B-2 under Live Fire Test and Evaluation (LFT&E) oversight in May 1995, after its strategic nuclear mission changed to include conventional weapons delivery. The LFT&E relied on data from limited past testing, plus reports and analysis from the government and contractor.

## **TEST & EVALUATION ACTIVITY**

B-2 IOT&E was followed by a period of FOT&E (through September 1998) and more recently by several increments of Force Development Evaluation (FDE). During FY01, FDE activity focused on the following areas:

- Evaluating B-2 aircraft software upgrade versions P1.3 and P1.4.
- Testing weapon delivery capabilities.
- Assessing survivability against selected threat systems.
- Evaluating reliability and maintainability of improvements to LO systems.
- Evaluating a deployable shelter for use by B-2.

## TEST & EVALUATION ASSESSMENT

B-2 effectiveness and suitability have changed very little from previous years. Improvements have occurred in several areas; however, the overall status of the B-2 has improved only slightly (since the changes resulting from software upgrade P1.1).

Although the B-2 cannot support the sustained operations requirements specified in the ORD and standards specified by the Air Combat Command (ACC), it has proven to be an effective weapon delivery platform, capable of striking targets anywhere in the world during combat operations (OAF & OEF). Assessments are provided for each of the five B-2 Critical Operational Issues: Rapid Strike; Sustained Operations; Mission Survivability; Weapons Effectiveness; and Reliability, Maintainability, and Deployability.

**Rapid Strike:** This area is marginally satisfactory. Time to generate and launch the B-2 is considered marginally satisfactory based on nuclear and conventional generation exercises conducted in FY00. However, regeneration timelines were not met due to the time required for LO maintenance (discussed below). If aircraft are allowed to accumulate a large number of LO discrepancies, generation times cannot be met. Nevertheless, since aircraft with LO defects can still be flown, training schedules can be met. Operational commitments for fully LO aircraft are supported by keeping a number of aircraft ready on the ground and not flying them, while conducting training with remaining aircraft.

As noted in previous reports, recent software upgrades beginning with version P1.1 have improved TF/TA performance to the point where operational requirements are met. Development testing of the improvements was completed; however, operational testing of TF/TA at the lowest altitudes has still not been completed. Air Combat Command (ACC) has placed a low priority on OT&E of TF/TA since conventional missions do not normally use TF/TA at the lowest altitudes.

Weapon System Reliability (WSR), which measures the probability that an aircraft will function correctly to reach the target and release weapons, continues to be rated as satisfactory for nuclear and conventional missions.

**Sustained Operations:** This area still does not meet requirements, primarily because of unreliability and difficulty in maintaining LO systems. Some improvements have already been fielded, but the most promising improvements to LO maintainability are still in development testing and have neither undergone OT&E nor reached the operational squadrons.

Mission Capable Rate (MCR) for FY 2001 was 31 percent, compared to an ORD requirement of 60 percent and an ACC standard of 50 percent. This represents a significant decline from FY 2000 (37 percent). The following major drivers impacted the MCR: continuing LO maintainability issues, shortage of fully qualified LO maintainers, and management decisions by 509<sup>th</sup> Bomb Wing to meet the flying hour program while deferring maintenance.

The MCR, not considering LO discrepancies, was 65 percent, also below that for FY00 and below the ACC standard of 80 percent. Major non-LO factors impacting MCR were: hourly post-operations inspections, power takeoff shaft failures, phase inspections, aircraft incidents, and failures of engine inlet seals.

Sortie Generation Rate (SGR) for FY01 at the MOB was comparable to the 0.2 sorties per aircraft per day seen in FY00. The ORD requirement for deployed SGR is considerably higher than the

rate achieved at the MOB. The required deployed SGR has yet to be demonstrated with an operationally significant number of aircraft and cannot be achieved without adequate shelters and substantial improvement to reliability and maintainability, not just to LO systems, but to other B-2 systems that affect downtime.

**Mission Survivability:** This area is satisfactory except for the DMS. There is no significant change to DMS performance since the improvements brought about in FY00 with the introduction of P1.1 aircraft software and changes to the mission data file. Although the system demonstrated improved location and identification performance and raised crew confidence in the information presented by the system, overall situational awareness provided by DMS remains marginally satisfactory. Location accuracy and response time performance against pop-up threats requires improvement. Improvements to DMS antennas and revised mission data files are anticipated in FY01 and may improve pop-up threat location accuracy.

During FY01, the 72nd Test and Evaluation Squadron conducted survivability assessments against three additional threat systems. Results of these assessments are used to validate signature templates used in mission planning for the B-2. Although the B-2's LO signature is considered satisfactory in the present configuration, introduction of new LO materials may lead to changes in aircraft signature and will require continued testing to update or validate signature templates.

**Weapons Effectiveness:** This area is satisfactory except for JSOW. Version P1.4 software has corrected some anomalies seen in earlier JDAM and JSOW testing. Five JDAM weapons were dropped in FY01 with only one anomaly (due to a broken lanyard). Miss distances for weapons that guided successfully were well within required values.

To date, only four JSOW weapons have been released from the B-2. Of these, early flights had several anomalies, in part due to B-2 software. On one early flight B-2 software caused a JSOW to fly direct to the target instead of flying through its planned waypoints. This error was corrected in software version P1.4. Two of the four JSOWs delivered by the B-2 had significant miss distances. The first involved an inadequate wind estimator model in the weapon software that will be fixed when JSOW version 9.0 software is fielded, and the second involved failure of the weapon guidance and control unit to acquire GPS and navigate correctly. Further testing is needed.

**Reliability, Maintainability, and Deployability:** This area is assessed as unsatisfactory because of poor reliability and maintainability of B-2 LO systems. Deployability of an operationally significant quantity of B-2s also remains undemonstrated.

A number of improved materials and processes are being introduced to improve LO reliability and maintainability. New caulks, paints, and fillers with improved cure times, currently being qualified, promise to reduce the repair times for some LO surface treatments. Additionally, several LO improvement and durability initiatives have been partially fielded and show promising results. These include modified designs for the crew entry door, jackpads, and arrowhead panels.<sup>1</sup>

The most significant LO improvement initiative is the AHFM configuration that replaces 60 percent of the caulk and tape surface treatment areas with MAGRAM. To date, this configuration has been applied only to the B-2 test aircraft at Edwards AFB. EMD and development testing of AHFM are

---

<sup>1</sup> Arrowhead panels on the underside of the aircraft provide access to the engine bay and engine exhaust nozzle bay.

complete and the program is proceeding with production on the basis of development testing alone. Minor design changes were accommodated in the production AHFM design with the intention of correcting problems seen in development testing, including significant areas of cracking and disbonding of MAGRAM from conductive sealant below the surface. Data showed that predicted AHFM MC Rate and MMH/FH reductions can be achieved in a development test environment (including a southern California high desert climate). A by-product of AHFM is that the test aircraft has already produced significant improvement in test operations and efficiency. Additional test issues awaiting resolution include how well AHFM aircraft meet signature requirements over the long term, whether design changes to correct early problems were successful, and how well the materials hold up in cold weather. If FDE in an operational environment bears out the program office's expectations, AHFM will represent a significant maintainability, sortie generation, and cost improvement over Block 30.

Only minor changes have occurred in the area of LO verification. Two LO verification tools were fielded in FY01: a resistive probe for evaluating surface conductivity and a hand-held reflectometer for evaluating the paint beneath AHFM coatings.

Development testing on a deployable B-2 Shelter System (B2SS) was conducted at Whiteman AFB in FY01. The shelter was erected and disassembled three times. The most recent assembly in June 2001 took a total of 34 days. Indications are that the shelter will provide adequate environmental protection for the B-2 but that assembly takes longer than desired. Additionally the shelters require concrete pads, aprons, and utilities. Because of these factors, ACC adopted an approach of erecting and maintaining B-2 shelters as semi-permanent facilities at forward operating locations (FOLs).

A production decision was made in September 2001 to buy four additional shelters and to upgrade the qualification shelter to a production level configuration. The first production shelter will be available to ship in April 2002. The qualification shelter will be upgraded, packed and ready to ship/store by mid-November 2001. Initial shelter operational capability (one shelter/fixed facility at each FOL) is expected in FY03 assuming adequate funding is appropriated.

**Live Fire Test and Evaluation (LFT&E):** LFT&E results were reported in the B-2 LFT&E Report submitted to Congress in March 2001. Based on review of the Air Force furnished documents, discussions, and briefings, the B-2 LFT&E program was inadequate. However, there was enough information to conclude that the vulnerability of the B-2 to threats expected on conventional combat missions could be reduced significantly using proven design approaches and relatively inexpensive available technology.

This Page Is Intentionally Left Blank



## **C-130 AIRCRAFT MODERNIZATION PROGRAM (AMP)**



The purpose of the C-130 Avionics Modernization Program (AMP) is to lower the cost of ownership of the U.S. military's C-130 fleet, while complying with the Air Force Navigation and Safety (Nav/Safety) Master Plan, Required Navigation Performance requirements, and other applicable Global Air Traffic Management (GATM) requirements. This will be done through a cockpit modernization program that replaces aging, unreliable equipment and adds equipment necessary to meet Nav/Safety and GATM requirements. New equipment is intended to lower the cost of ownership by reducing cockpit crew manning, increasing aircraft reliability, maintainability, and sustainability as well as the number of different aircraft configurations. The C-130 AMP should also provide an improved precision airdrop capability for the combat delivery fleet, meet Night Vision Imaging System (NVIS) requirements, and improve the C-130's precision approach and landing capability. This program also provides the interfaces necessary to integrate real time information in the cockpit. A standard cockpit layout is planned allowing crewmembers to be trained to fly in one aircraft type and required to undergo mission qualification only when reaching their new units—unlike the current situation.

### **BACKGROUND INFORMATION**

A C-130 AMP/Common Avionics Architecture for Penetration (CAAP) Test Planning Working Group has been established to provide a forum for all cognizant test organizations to participate in the C-130 AMP/CAAP test planning process. The Responsible Test Organization (RTO) for AMP/CAAP Developmental Test & Evaluation is the 418<sup>th</sup> Flight Test Squadron (FLTS) at Edwards AFB, CA. The using commands and AFOTEC will provide crew members, as required, to support ground and flight tests during combined DT/OT and dedicated OT&E. The RTO is responsible for conduct of DT&E testing, detailed test planning, and reporting of test results to the Program Managers. Participating Test Organizations include, but are not limited to, the 339<sup>th</sup> Flight Test Squadron at Robins AFB, GA, and Detachment 1 of the 46 Operations Group at Hurlburt Field, FL. The Program Office will manage the LFT&E program.

OT&E will be conducted by AFOTEC, with support from the program office and the using commands. DT&E and OT&E test objectives and sorties will be combined to the maximum extent possible. Force Development Evaluations may be conducted by the Air Mobility Command's, 33<sup>rd</sup> FLTS and by the Air Force Special Operations Command's 18<sup>th</sup> FLTS.

## **TEST & EVALUATION ACTIVITY**

DOT&E has participated in the IPTs that prepared for the Milestone II decision. The Milestone II decision resulted in the Boeing Company being awarded the C-130 AMP contract in July 2001. A Test Planning Working Group and a LFT&E IPT have been created to formulate the specifics of the LFT&E program and the TEMP. The C-130 AMP TEMP was approved by DOT&E in July 2001. The TEMP is currently being revised to include specific details applicable to the winning contractor.

The AMP test strategy presumes that contractor ground tests will be conducted at the Boeing facility in San Antonio, Texas, the plant at Long Beach, and Edwards AFB. Following a series of shakedown flights at the contractor facility, initial prototypes will transition to the RTO facility at Edwards AFB for the start of formal DT&E. DT&E flight tests will be accomplished by a combined government and contractor Integrated Test Team under the direction of the RTO. AFOTEC personnel will participate as part of the government contingent.

## **TEST & EVALUATION ASSESSMENT**

The successful testing of AMP components across a broad range of aircraft configurations and mission requirements will be a significant challenge. The concept is feasible; however, it is unlikely to succeed unless the various users commit to a unified fleet management approach for the modification of all aircraft. Fleet management of more than 700 aircraft is one of the keys to success. A tentative plan calls for some aircraft being retired, others being moved from one unit to another to manage structural life, some sent to depot, and still others used for test purposes. Identifying aircraft by tail number, without regard to unit ownership, is efficient, but it is not popular.

The following lists the different Mission Design Series (MDS) of the C-130s to be modified and some of the special test requirements for them:

**Quantities of C-130 and Special Test Requirements by MDS**

<b>MDS</b>	<b>Nomenclature</b>	<b>Special Tests</b>
C130E/H/H1/H2/H3	Combat Delivery	GATM, TCAS, TAWS, NVIS, FMS
AC-130H/U	Gunship	Gunfire Accuracy, ESA, Defensive
EC-130E	ABCCC	Mission Unique
EC-130H	Compass Call	Mission Unique
HC-130N/P	Combat Rescue	Mission Unique
MC-130E	Combat Talon I	TF/TA Navigation
MC-130H	Combat Talon II	TF/TA Navigation, ESA, Defensive
MC-130P	Combat Shadow	Mission Unique
LC-130H	Ski	Mission Unique

## **C-130J AIRLIFT AIRCRAFT**



The C-130J Hercules II is a medium-range, tactical airlift aircraft designed primarily for the transport of cargo and personnel within a theater of operations. The cargo area can adapt to accommodate a combination of passenger, cargo, and/or aeromedical airlift missions. Variants of the C-130J will perform missions such as psychological operations (EC-130J), weather reconnaissance (WC-130J), and aerial refueling (KC-130J).

The C-130J retains many structural characteristics of the C-130H, having the same overall interior/exterior dimensions. However, the C-130J is more than 70 percent unique, relative to previous models. Significant differences include an advanced integrated digital avionics system, a redesigned flight station intended to facilitate a two-person cockpit, a new propulsion system intended to provide improved take-off, climb and cruise performance, and cargo compartment enhancements.

### **BACKGROUND INFORMATION**

The C-130J aircraft is a contractor-initiated improvement upon the C-130H-3. The United Kingdom, Australia, and Italy have purchased variants of the C-130J design. Creation of a C-130J acquisition program within DoD was directed to provide U.S. Air Force oversight of aircraft development. The C-130J aircraft procurement is proceeding under a commercial acquisition strategy.

Contractor DT&E commenced in spring 1996 and will likely continue through 2003. DT&E has focused on the satisfaction of aircraft requirements defined in the Model Specification. Government Qualification Test and Evaluation has occurred in two formats. Initially, it evaluated designated military utility issues. Subsequently, a Follow-On Test Program was established by the Air Force to permit evaluation of incremental development progress as well as formation airdrop, the towed-parachute retrieval system, defensive systems, and survivability.

DOT&E designated the C-130J aircraft for LFT&E Oversight in May 1995. In March 1998, the Director of OT&E and the Assistant Secretary of the Air Force agreed to a LFT&E program that addresses wing dry bay fire, composite propeller ballistic vulnerability, wing fuel tank hydrodynamic ram effects, engine and engine bay fires, vulnerability to man-portable air defense systems threats, and mission abort vulnerability. The agreement established a joint DOT&E/Air Force C-130J LFT&E program that takes advantage of testing and evaluation under both the DOT&E funded Joint Live Fire (JLF) program for the C-130E/H and the Air Force funded C-130J (LFT&E program) vulnerability

reduction program. The JLF program addresses potential vulnerabilities of wing fuel tanks to hydrodynamic ram impact and mission abort vulnerability. A TEMP describing the program was submitted to and approved by DOT&E in July 1999.

The Federal Aviation Administration (FAA) awarded Lockheed Martin a Type Certificate for a commercial version of the C-130J-30 aircraft (a stretch model designated as the 382J, which currently exists only on paper) on September 9, 1998. However, significant C-130J and C-130J-30 military requirements are not included in the FAA certification. This necessitates additional testing by the Air Force and other U.S. government users.

### **TEST & EVALUATION ACTIVITY**

Qualification testing for mission software Version 5.3 was completed in May 2001. A number of deficiencies were identified for corrective action and retest. Operational testing of Version 5.4 is now scheduled for late CY04. The OT test team will test the interim versions as they are released. The operational test plan is being revised to reflect the current structure of the test program.

Contractor developmental testing and Air Force regression testing included airdrop testing at Edwards AFB and Pope AFB, with the support from the Army at Ft. Bragg.

Live Fire Test and Evaluation Phase 2 (composite blade testing) has finished testing and the team is in the process of analyzing the data. Phase 3 (manpads assessment) is complete. Engine nacelle testing has been funded (phase 4) and planning has started.

### **TEST & EVALUATION ASSESSMENT**

Issues confronting the C-130J program have included: (1) logistics support and training systems funding; (2) delayed FAA certification; (3) hardware, software, and technical order deficiencies; (4) manufacturing quality; (5) sub-system reliability; (6) failure to meet required measures of system effectiveness and suitability; (7) lead command responsibilities; (8) resolution of documented deficiencies; (9) schedule credibility; and (10) parallel development of numerous variants to the basic platform.

These issues will continue to affect the program as it progresses through developmental testing and moves toward the final phase of operational testing and concurrent delivery of aircraft to selected users undergoing unit conversion training. Operational capabilities will be limited for the foreseeable future.

The overriding shortfall has been in software development and integration. A second critical issue impacting both OT&E and user implementation has been the lack of funding for logistics support and training systems. Future logistics shortfalls appear likely to render the C-130J not operationally supportable. Interim contractor support, repairable items, logistics and maintenance data, and maintenance training will all be degraded. These shortfalls will limit operational deployment of the C-130J.

Based on the evaluation test results, the aircraft is not operationally effective for the airland mission. Aircrew workload issues, software discrepancies, and cargo loading and constraint requirements were major contributors. The using command is unable to verify manpower requirements

to field this system until the crew workload evaluation is complete. Since the 400 lb paratrooper discrepancy has been lifted, paratroop airdrop testing has commenced. Airdrop evaluation is ongoing.

In addition, the aircraft is assessed as not suitable. The reliability, maintainability, availability, and logistics supportability demonstrated during Phase 1B were below operational requirements. Deficiencies were noted with on-aircraft integrated diagnostics and fault isolation systems, portable maintenance aids, maintenance technical orders, and availability of spare parts. Additional contractor field service representatives will be required to assist in the maintenance of the aircraft for the foreseeable future.

Although Block Upgrade 5.3 showed improved navigation functions, flight displays, technical publications, and reduced nuisance faults, there remains a large number of open deficiency reports that need to be resolved to achieve operational capability. Testing of full operational capability will not occur until the delivery of the Block 5.4 upgrade (Phase 2).

This Page Is Intentionally Left Blank

## **C-17 GLOBEMASTER III AIRLIFT AIRCRAFT**



The C-17 is a four-engine turboprop aircraft capable of airlifting large payloads over intercontinental ranges without refueling. It is intended to allow delivery of outsize combat cargo and equipment directly into austere airfields. The C-17 is required to deliver passengers and cargo between continents, provide theater and strategic airlift in both airland and airdrop modes, and augment aeromedical evacuation and special operations missions.

Significant features of the C-17 include a supercritical wing design and winglets to reduce drag; in-flight refueling capability; externally blown flaps; direct lift control spoilers; high impact landing gear; a forward and upward thrust reverser system that provides backing capability; a cargo handling system that permits operation by a single loadmaster; a two-person cockpit; and maximum use of built-in test equipment to reduce maintenance troubleshooting times.

### **BACKGROUND INFORMATION**

IOT&E of the C-17 was conducted in four phases from May 1992-June 1995. Based upon results of IOT&E and live fire testing, DOT&E submitted an Operational and Live Fire Test and Evaluation Report (B-LRIP) to Congress in November 1995. The report assessed the operational effectiveness and suitability of the aircraft to conduct operational missions within the context of the existing airlift system. The C-17 was judged to be operationally effective (with limitations) and operationally suitable. Survivability was not sufficiently evaluated to make an assessment. A full-rate production decision, Milestone IIIB, was made in November 1995. A three-year initial period of FOT&E commenced in June 1996.

IOT&E cited deficiencies associated with personnel airdrop, including equipment and procedural shortcomings. Specific areas requiring further evaluation during FOT&E included exit rate for static line personnel drops, combination paratrooper and bundle drops, and development/refinement of personnel airdrop formations.

The C-17A completed LFT&E in 1994. Since completion of that testing, two major structural modifications have been incorporated that may require further LFT&E. The horizontal tail has been changed to a composite material construction, and an extended range fuel containment system (ERFCS) has been added in the center-wing area of the fuselage. These changes could significantly affect aircraft survivability. Furthermore, based on the total cost of these changes, the upgrades could constitute a new

program since their costs exceed that of a major system development. DOT&E has initiated a review of all changes made to the C-17 since the LFT&E report was published in November 1995.

Most of the sub-standard items identified in IOT&E have been closed. This includes deficiencies (did not meet ORD criteria), inadequacies (qualitative assessment that failed), recommendations (met criteria but had problems which could be improved), and deferrals (test not accomplished during IOT&E). Although all deficiency items are considered closed, fault isolation procedures/manuals and built-in test equipment require improvements, and the Strategic Brigade Airdrop mission has operational limitations. Efforts to include dual-row cargo/equipment airdrop are in progress to shorten the drop zone delivery time.

### **TEST & EVALUATION ACTIVITY**

One high visibility FOT&E item still in progress is an improvement to the On-Board Inert-Gas Generating System (OBIGGS). High failure items (e.g. compressor, air separation module and bleed pressure regulator) are tracked on a weekly basis to ensure adequate spares exist. Funding for the OBIGGS improvement program is being considered for FY03.

Developmental Test and Evaluation will continue at Edwards AFB under the heading of the Follow-On Flight Test Program. AFOTEC-Detachment 5 at Edwards AFB will maintain involvement through ongoing communication with the Program Office and the C-17 Test Team resident at Edwards AFB.

C-17 FOT&E activities and program developments that affect program limitations identified in the B-LRIP report to Congress are being monitored. These include the OBIGGS, the composite material horizontal tail construction, ERFCS, crew protection armor, liquid oxygen bottle design, and other changes.

### **TEST & EVALUATION ASSESSMENT**

The apparent limited capability for dual-row airdrops (release of two rows of cargo platforms positioned side-by-side in the aircraft) may necessitate sequential (side by side) release rather than simultaneous release of the special 88-inch wide by 16-foot long platforms to prevent collisions after they exit the aircraft. The resultant effect is an increase in delivery time and required drop zone length; however, the total number of aircraft required to drop equipment for a brigade has been reduced. At present, the combined effects of dual-row airdrop and aircraft spacing for personnel drops have positively impacted the strategic brigade airdrop execution time, which is approaching the Army's goal. In addition, the C-17 is incurring erroneous displays while flying in formation (SKE2000 station keeping equipment). These problems occur without adequate warning to the crew. Testing to verify fixes should result in operational restrictions being lifted by February 2002.

The Program Office is revising the TEMP to better address continuing flight tests, particularly the Follow-On Flight Test Program at Edwards AFB and continued operational testing by the 33 Flight Test Squadron (FLTS) at McGuire AFB. The current TEMP was approved in 1995. A revised TEMP will better address follow-on developmental testing at Edwards AFB and operational testing by AFOTEC and the 33 FLTS. In addition, an updated OT test plan will be submitted. The updated plan will focus a more detailed scope of the proposed testing for the next four years. In addition, AFOTEC will have an



increased role in future operational testing to include Global Air Traffic Management upgrades. The TEMP will also define the future LFT program.

Challenges to developmental and operational flight testing in 2002 and beyond include constraints to individual project budgets, test resources, and aircraft availability for test. Only a single dedicated aircraft exists for developmental flight testing. Requests for flight test time on operational aircraft are in stiff competition with high operational mission demands. Also, the large number of aircraft scheduled for modification has limited the available aircraft to perform mission requirements and testing. These challenges have affected the depth and duration of testing conducted following aircraft modification and upgrade.

The C-17 passed the 296,000 flight-hour mark in August 2001. The Mission Capable (MC) and Fully Mission Capable (FMC) rate have been tabulated. Results of both measures, presented as a range of monthly averages over three different measurement periods, are shown below, together with standards from the 1993 ORD and the 1998 ORD.

**C-17 Flight-Hour Mission Capable (MC) and Fully Mission Capable (FMC) Rates**

**Measured Values**

	<b>Jun 93-Aug 95</b>	<b>Sep 95-Aug 97</b>	<b>Sep 97-Sep 99</b>	<b>Oct 99-Sep 01</b>
<b>MC</b>	30.5-83.5%	75.7-93.0%	81.7-91.1-%	78.6-85.9%
<b>FMC</b>	0-74.4%	7.8-75.0%	41.6-71.5%	37.6-64.3%

**Standards**

	<b>1993 ORD</b>	<b>1998 ORD</b>	<b>AMC FY98 Standards</b>
<b>MC</b>	82.5%	90.0%	87.5%
<b>FMC</b>	74.7%	80.0%	77.5%

Notes: Standards for MC are threshold (minimum acceptable) values while FMC standards are deemed objective values (goals).

Aircraft are experiencing main landing gear post lug failures. A fleet post lug inspection is being considered using the ultrasound non-destructive inspection method to investigate this problem.

This Page Is Intentionally Left Blank

## **C-5 RELIABILITY ENHANCEMENT AND RE-ENGINEERING PROGRAM (RERP)**



The current C-5 fleet operates throughout the Active, Reserve, and National Guard components in various missions and environments. C-5 missions include strategic airlift, emergency aeromedical evacuation, airland transport of a brigade-size force in conjunction with other organic aircraft, transport of outsize and oversize cargo, and multi-ship Special Operations Low Level II. The C-5 aircraft must perform missions at night and in adverse weather, and it may employ aerial refueling during intercontinental missions.

### **BACKGROUND INFORMATION**

The C-5 Reliability Enhancement and Re-engining Program (RERP) upgrades the aircraft propulsion system. It integrates commercial engines, nacelles, thrust reversers, and pylons into the existing C-5 airframe. These performance improvements are designed to optimize cargo carrying capabilities, allowing fully loaded take-offs and landings on relatively short runways, and meet the performance requirements of the Global Air Traffic Management initiative. Additionally, re-engining is expected to provide significant reliability, maintainability and availability improvements. A commercial engine support concept (two levels of maintenance, warranties, power by the hour, etc.) will be integrated into the C-5 logistics support system infrastructure. Other candidate sub-systems for reliability enhancement include the flight controls, hydraulics, environmental, electrical, and fuel systems. Specific upgrades and the extent of the expected reliability improvement will be identified from recently completed trade studies.

The C-5 was developed and procured prior to the implementation of LFT&E statutory requirements. Therefore, the basic aircraft has never completed a live fire evaluation. The RERP modification is an ACAT I program, and constitutes a covered program for LFT&E.

### **TEST & EVALUATION ACTIVITY**

The C-5 RERP TEMP was approved October 2001 in support of a Milestone B decision. No testing has been conducted to date. Only preliminary test planning has occurred thus far. DOT&E has been an active participant in the development of the TEMP, in the review and revision of the acquisition strategy, and in the DoD IPT process.

LFT&E activity has focused on identifying potential LFT&E issues, developing an LFT&E strategy, and updating the TEMP to incorporate LFT&E requirements. To support the LFT&E strategy, the Air Force is conducting modeling and simulation to evaluate C-5 survivability against man-portable air defense systems (MANPADS). Several models are being used, namely, FASTGEN (Fast Shotline Generator), COVART (Computation Of Vulnerable Area and Repair Time), MOSAIC (Modeling System for Advanced Investigation of Countermeasures), SPIRITS (Spectral and In-band Radiometric Imaging of Targets and Scenes), and FISTA (Flying IR Signatures Technology Aircraft). DOT&E has supported a request for a waiver from full-up, system-level testing since testing a complete, combat configured system would be unreasonably expensive and impractical. The LFT&E plan was approved in October 2001.

### **TEST & EVALUATION ASSESSMENT**

The schedule risk for the C-5 RERP development and test programs is moderate to high. The C-5 RERP test program is dependent on the success of the C-5 Aircraft Modernization Program (AMP), which is avionics and software intensive. Any slip in the C-5 AMP program schedule will impact the schedule of the C-5 RERP since the single engineering and manufacturing development aircraft will be a modified C-5B from the C-5 (AMP) test program. The current acquisition strategy will modify four C-5B aircraft for system development and demonstration. A single C-5A Manufacture and Qualification Test program, if approved, will commence in FY09.

## COMBAT SURVIVOR EVADER LOCATOR (CSEL) SYSTEM

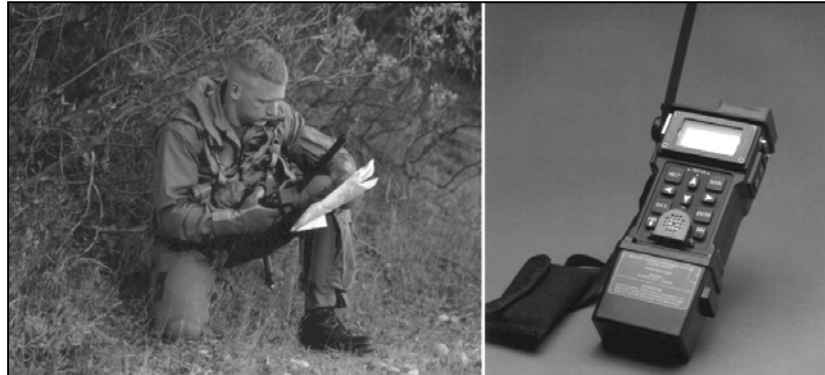

The Combat Survivor Evader Locator (CSEL) is the next generation, survival radio/personnel locator system designed to provide accurate survivor/evader (S/E) location and reliable two-way communication between S/Es and rescue elements. CSEL allows the command elements and search and rescue forces to locate and maintain communication with CSEL-equipped isolated personnel.

CSEL is more than a hand-held radio. It is a complex aerospace command and control system including radios, support equipment, unmanned base stations, and rescue center workstations. The system relies on support from many systems including UHF Satellite Communications (UHF SATCOM), Secret Internet Protocol Network (SIPRNET), National Systems, Search and Rescue Satellite Aided Tracking System (SARSAT), and Global Positioning System (GPS).

The Hand Held Radio (HHR) uses UHF/VHF line-of-sight voice, beacon, precise GPS, and three Over the Horizon (OTH) data communications modes to provide worldwide coverage. GPS position is included in all OTH transmissions. The radio support equipment consists of the unit-level CSEL planning computer and radio set adapter. The OTH segment includes four unattended UHF Base Stations (UBSs) that control SATCOM communications with the HHRs and interface with National Assets, SARSAT, and Joint Search and Rescue Centers (JSRC) via the SIPRNET. The ground segment displays and prepares messages for transmission to/from the HHR through the UBS.

### **BACKGROUND INFORMATION**

The Air Force initiated CSEL as an Acquisition Reform, 18-month program to rapidly field the system. CSEL is intended to replace the current PRC-90 and PRC-112 survival radios. The program was placed under DOT&E oversight in spring 1998 because of its importance to joint warfighting, congressional interest, and potential impact of CSEL integration into DoD C4I systems.

AFOTEC conducted an operational assessment (OA1) from April-July 1998. It included data and observations from combined ground based and shipboard testing, participation in joint rescue exercises, and water and cold weather testing in Alaska. The CSEL EMD configuration tested in OA1 was neither effective nor suitable. As a result of OA1 deficiencies, the Air Force delayed purchasing 891 production radios, restructured the program, and adopted a spiral development approach. The OA1 system was designated Spiral 1. Spiral 2 included corrections to most of the OA1 problems and was tested in September 1999. Spiral 3 HHRs were used for OA2 in March 2001 and included the following

functionality: secure two-way UHF SATCOM; SARSAT capability; UHF and VHF Voice; and GPS Selective Availability Anti-Spoofing Module (SAASM). Multi-Service OT&E (MOT&E) is scheduled for October 2002, using production representative radios similar to the OA2 radios but with a SAASM hardware configuration improved to reduce cost and enhance producibility while retaining all the functionality of the OA2 configuration. The new SAASM will undergo developmental and combined testing prior to MOT&E. Spiral 4 will be for FOT&E and will include software upgrades to enable Demand Availability Multiple Access (DAMA)-compatible UHF SATCOM and Defense Information Infrastructure Common Operating Environment Level 7 Interoperable Joint Service Rescue Centers (JSRCs).

A full-rate production decision is planned for 3QFY03. The F-117 and F-16 losses during Operation Allied Force increased DoD focus on the CSEL program. The Commanders in Chief, U.S. Central Command and U.S. Special Operations Command, requested program acceleration. In addition, current counter-terrorist activities have elevated the need for CSEL, resulting in the Services also requesting acceleration.

### **TEST & EVALUATION ACTIVITY**

Operational Assessment #2 was conducted in FY01. It included observations from combined DT/OT, as well as water and jungle testing. OA2, using 22 radios and support equipment, a UBS, and four JSRC workstations, supported a proposed decision to buy 376 production radios. As a result of OA2, 35 production radios with the OA2 SAASM, and 341 radios with the improved SAASM were purchased. These will be used for DT and combined DT/OT in the summer of 2002 to mitigate risk to MOT&E. The OTAs, led by AFOTEC, requested 110 production representative HHRs to conduct MOT&E.

An update to the TEMP is in coordination and is expected to be approved in February 2002.

### **TEST & EVALUATION ASSESSMENT**

The OA2 configuration was determined to be potentially effective and suitable, but CSEL was not ready for operational employment. Seven areas required corrective action prior to MOT&E: Concept of operations, battery, training, manning requirements, ORD requirements, fielding plan, and communications infrastructure. Only three of the seven are directly attributable to the CSEL system: battery, training, and manning requirements. The remaining four must be addressed by the Services and Combatant Commands, not solely by the contractor or the Program Office. Since OA2, the contractor has announced that all deficiencies generated from both OA1 and OA2 have been corrected. These fixes will be validated during DT3 in March 2002. There are no mission critical deficiencies requiring resolution prior to MOT&E.

### **LESSONS LEARNED**

An overarching lesson for CSEL has been the importance of early coordination with external agencies. This has proven true in CSEL development, not only with systems it depends on and supports, but also with a user community that has never had such a capability. The program has experienced a number of problems attributable to poor/late coordination, although some of these may have been exacerbated by the program accelerations. There have also been problems with access to the systems on

which CSEL depends. Next, the planners, operators, and maintainers have not understood how the capabilities and limitations of these systems affect CSEL. Also, users must be an early and integral part of the program, particularly when a new concept is accelerated. In some areas, development has outpaced the user community's preparations to receive it. This has not only created problems with fielding and support, but with the ability of the users and testers to discover and articulate functional, operational and support problems with the system. In addition, users, trainers, testers, and acquisition personnel must consider the entire system, but some have not been involved in the program enough to appreciate this. Concept of operations, fielding, manning, training, and support have been slighted in the rush to produce a 'radio.'

Another lesson learned in CSEL has been the utility of early and often OT involvement. The program has been consistently pushed into an aggressive schedule of near concurrent development and field-testing. In addition, demanding performance and reliability requirements have kept the program on the leading edge of technology. As a result, the technology at times has been too immature for the users to field. Early OT involvement in the rapid development cycle and combined DT/OT have allowed the Services to evaluate the system, thereby identifying significant issues early in CSEL's development.

This Page Is Intentionally Left Blank



## **DEFENSE CIVILIAN PERSONNEL DATA SYSTEM (DCPDS)**



The Defense Civilian Personnel Data System (DCPDS) will provide the software application tools and the requisite hardware to support civilian personnel mission requirements for DoD. Its genesis was the regionalization of DoD personnel data centers, with the consolidation of personnel service centers. DCPDS complements regionalization in that the automated tools it provides will facilitate the expected decrease in the personnelist to customer service ratio (from 1:50 to 1:100).

The basic design of the system is a client-server architecture. Data entered into the system at the Customer Support Units will update the database at one of the Service's Regional Service Centers. The database of record for each Service's region (and for each DoD agency) will reside at its respective Regional Service Center. The Civilian Personnel Management Service will keep a DoD enterprise database for survey and planning purposes.

### **BACKGROUND INFORMATION**

In FY96, DCPDS underwent an Operational Assessment (OA) to evaluate the success of initial personnel process improvements provided by DCPDS, but it was found that these enhancements were not being employed. Another OA was conducted during FY97, which noted marked improvement, due in part to the increased emphasis after the first assessment.

During FY98 and early FY99, T&E activities were limited to developmental and technical testing. This activity included software unit testing and integration testing in which the system's end-to-end performance was tested in a laboratory environment. The formal Software Qualification Test (SQT), the last DT prior to OT, was initiated. Representatives from the components participated in the integration testing and the SQT.

During the period extending from June 1999 to February 2000, AFOTEC conducted QOT&E on DCPDS at several test sites in two stages—system level evaluation and dedicated OT&E—in accordance with the DOT&E-approved TEMP and Operational Test Plan (OTP). AFOTEC employed a new test approach, Combined Test Force, to maximize the sharing of data collected at all phases of testing.

The dedicated OT&E phase was conducted during 2QFY00 at civilian personnel offices located at Ft. Richardson, AK; Ft. Shafter, HI; Silverdale, WA; McChord AFB, WA; and Randolph AFB, TX. This test phase was managed and controlled exclusively by AFOTEC, which used mission task

accomplishment analyses to evaluate DCPDS operational effectiveness and suitability. Several shortcomings in the execution of QOT&E were noted by DOT&E. Prominent among these were inadequate data collection during the dedicated OT phase and frequent system baseline changes during the test events. However, the most significant shortfall was that operational requirements were reduced by Civilian Personnel Management Service (CPMS) just prior to the start of the dedicated OT phase. Accordingly, no testing was carried out to evaluate the performance of several major system capabilities. As a result of these and other shortcomings, DOT&E directed that additional testing be completed prior to full fielding. This initial QOT&E activity was subsequently labeled QOT&E Phase I.

### **TEST & EVALUATION ACTIVITY**

The Follow-on OT&E, labeled Phase II QOT&E, was conducted by AFOTEC over a 2-week period in July and August 2001, at three test sites in Fort Benning, GA; Redstone Arsenal, AL; and San Diego, CA. Phase II was designed to evaluate the deferred (from Phase I) functionalities and the pre-planned upgrades (released since Phase I QOT&E), to resolve COI 1 (Administrative Training), which was resolved as unsatisfactory for Phase I, and to re-evaluate other deficiencies noted during the Phase I testing, such as Mass Action—which include Mass Pay, Mass Realignment, and Mass Appraisals.

### **TEST & EVALUATION ASSESSMENT**

During the Phase II testing, AFOTEC observed that the majority of the users rated the deferred functionalities and pre-planned upgrades as “largely acceptable” or “completely acceptable.” AFOTEC, however, was unable to completely resolve COI 1 (Administrative Training), because some of the required capabilities were not installed at the test sites, hence could not be observed. Surveys of users at the five test sites showed a 60 percent approval rating of the Mass Action functionalities, including Mass Pay, Mass Realignment, and Mass Appraisals. AFOTEC concluded that DCPDS was operationally effective and suitable; DOT&E agreed except for COI 1 and Mass Actions. DOT&E has required additional testing of the previously unobserved Administrative Training capabilities and the Mass Action functionality.

## **E-3 AIRBORNE WARNING AND CONTROL SYSTEM (AWACS)**



The E-3 AWACS is a commercial Boeing 707-320C airframe modified with an AN/APY-1 or AN/APY-2 radar. It is also equipped with general and specialized mission computers, multi-purpose displays, and clear and secure multiple-voice and data link communications. The United States has a total of 33 E-3s, assigned to Pacific Air Forces and Air Combat Command. AWACS has been employed in support of joint and multinational operations around the world. NATO, Great Britain, France, and Saudi Arabia also operate variants of the E-3. Finally, Japan operates a variant of the E-3 installed on a 767.

The Air Force is currently studying what upgrades to include in the next major AWACS modification, Block 40/45. This upgrade centers on replacing the current mission computer and the operators' terminals, with a COTS computer and a network of operator workstations. All software will be rewritten according to current standard business practices. This upgrade will enable the Air Force to incorporate several necessary improvements to AWACS functionality including multi-source integration (MSI), increased electronic support measures (ESM) system memory, integration of the Intelligence Broadcast System (IBS), and data link infrastructure (DLI). These improvements will be achieved by new tracking algorithms, software control of the communications subsystem, improved human-machine interfaces, and improved data link latency. The Block upgrade supports continued improvements to E-3 information correlation functions that will enable the E-3 to support SIAP and will extend AWACS capabilities through the 2025-2035 timeframe.

### **BACKGROUND INFORMATION**

Since initial fielding, the U.S. E-3 AWACS has undergone nearly continuous modification. The most recent prior to Radar System Improvement Program (RSIP) was the Block 30/35 upgrade, which included significant improvements in navigation, communication, central mission computer, and electronic support measures (ESM) capabilities.

RSIP replaced the aging AWACS radar sub-system computer, the Airborne Radar Technician workstation, other selected radar system hardware and software, to improve pulse-Doppler radar sensitivity and resistance to electronic countermeasures. RSIP also increased reliability and maintainability of the modified components, including increased radar sensitivity.

Block 40/45 will replace the aging AWACS computer system, and the operator's terminals with a network of commercial-off-the-shelf (COTS) operator workstations linked to several UNIX-based COTS computers. This configuration will be connected by a Gigabit Ethernet LAN and adds digital communications both for control of the radios and for internal communications. The baseline for the Block 40/45 upgrade will be the NATO Mid-Term Upgrade. Block 40/45 will improve E-3 reliability and availability, providing theater commanders significantly enhanced surveillance and control capabilities while contributing to information superiority needed to control the battlespace.

### **TEST & EVALUATION ACTIVITY**

The USAF is currently scoping the Block 40/45 development effort, including the development of a TEMP. DOT&E is participating in this process and is sharing lessons learned from the Navy's E2C multi-system upgrade that included Cooperative Engagement Capability. Block 40/45 testing will combine developmental and operational tests. Test data from NATO and U.K. tests/exercises will be used to reduce test costs and duration. In addition to leveraging existing activities wherever practical, modeling and simulation will be employed to evaluate maturity and maximum capacity of some of the Block 40/45 components. The USAF has been using modeling and simulation to interface with operators to get their comments on performance as part of the pre-EMD risk reduction activities. The Block 40/45 development and test employs the "spiral" approach.

### **TEST & EVALUATION ASSESSMENT**

Re-hosted radar software led to problems during the RSIP program. The problems were due to inadequate protection of aircraft radar hardware under certain operating conditions and degrading the long-range detection and tracking performance of the Beyond-The-Horizon radar. Both those issues have been corrected and steps were taken in both the ground and air test procedures to prevent recurrences. However, numerous in-flight failures of software routines resulted in low Mean Time Between Failure and remains a concern for RSIP. The Block 40/45 program will require re-hosting significantly more software. DOT&E will advise the 40/45 program to prevent a repeat of the types of problems experienced with the RSIP program.

## EVOLVED EXPENDABLE LAUNCH VEHICLE (EELV)

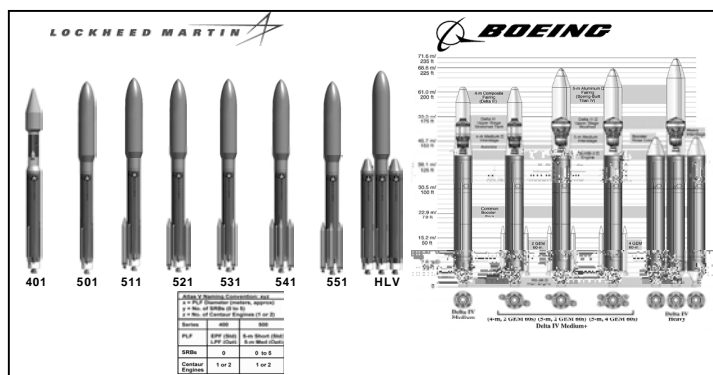

The Evolved Expendable Launch Vehicle (EELV) program will provide launch services for government satellite launch requirements currently served by Delta II, Atlas II, Titan II, and Titan IV. The EELV will be DoD's only medium, intermediate, and heavy payload space launch capability after current heritage inventories have been exhausted. The transition from current launch systems begins in FY02. EELV is expected to provide launch services through 2020.

The EELV system includes launch vehicles, infrastructure, support systems, and interfaces. Payload interfaces, launch pads, and infrastructure will be standardized so all configurations of each contractor's EELV family can be launched from the same pad, and so payloads can be interchanged between vehicles in the same class (i.e., medium, intermediate, or heavy). The EELV program will maintain current mass-to-orbit capability while increasing launch rate and decreasing costs. The EELV program is designed to reduce the cost of space launch by at least 25 percent compared with existing systems. Potential savings will be generated through the commercial launch market and shared development by government and commercial customers.

The EELV program uses a streamlined development approach to build a launch services capability. DoD will acquire launch services, while production and launch operations responsibilities remain with the contractor. The government will maintain an ongoing competition between two contractors rather than down-select to one. The two contractors are Boeing and Lockheed Martin. Boeing's EELV family of launch vehicles is designated the Delta IV, and Lockheed Martin's family of launch vehicles is designated the Atlas V. The contractors share development costs with the government to satisfy both DoD/civil launch requirements and commercial launch needs.

### BACKGROUND INFORMATION

The EELV program is a contracted launch service. Under this concept, launch service contractors have total system performance responsibility and retain ownership of all EELV flight hardware and launch pad structure. Launch pad real property and other on-base facilities required for operations are leased to the contractors. The EELV acquisition strategy uses government insight into contractor designs, processes, and operations to meet operational requirements. Insight is an operational risk management approach requiring minimum governmental involvement into contractor processes and operations.

The 1998 EELV Test and Evaluation Master Plan (TEMP), which is currently outdated and in need of revision, describes a test strategy that relies almost exclusively on combined developmental/operational testing. Due to the current acquisition strategy, there are no dedicated test events. The test strategy includes extensive use of models and simulations to predict individual sub-system and total system performance. Despite the ostensibly commercial nature of the program, the government needs to evaluate system performance, interoperability, standardization, and the ability of each launch system to support launch requirements using only two national launch ranges. There is an Operational Assessment (OA) currently in progress, and Initial Operational Test and Evaluation (IOT&E) is planned to begin in July 2002.

### **TEST & EVALUATION ACTIVITY**

Boeing and Lockheed Martin continued conducting qualification testing at the component and sub-system level for their respective families of launch vehicles with government insight provided by the EELV System Program Office (SPO). The SPO has made very little of this data available to the DoD test community, citing a lack of contractual requirements for formal reporting of the results and the attendant difficulties of assembling products suitable for external distribution.

DOT&E has not had the opportunity to observe any EELV test activities first-hand, but has visited production facilities and launch facilities for Delta IV and Atlas V. DOT&E participated in periodic, SPO-conducted, government-only reviews of the entire program as well as integration activities. Although only limited data was available at these reviews, DOT&E was able to determine the key issues and areas of concern for the program. DOT&E also participated in Test Integrated Process Team meetings, with the goal of establishing a process for updating the TEMP and ensuring critical documentation and data are available for independent review and analysis.

### **TEST & EVALUATION ASSESSMENT**

Based on DOT&E's participation in the periodic program reviews and limited insight into contractor-conducted test activities, there do not appear to be any insurmountable problem areas that would preclude starting Delta IV and Atlas V System Development Testing with pathfinder vehicles in December 2001 or conducting the first two commercial launches in May 2002. There is, however, critical documentation that needs to be evaluated by DOT&E prior to the first government payload launch on Delta IV, now scheduled for July 2002. Most important are the Post Flight Analysis Plan (PFAP) and the TEMP. The PFAP has not yet been released from the SPO for outside review, and the TEMP, as stated above, is in need of revision. The OA will support Air Force Space Command's launch readiness review for the first government payload launch. DOT&E will be better able to assess the readiness for the first government launch after observing pathfinder processing, independently reviewing the data, and after reviewing the documentation relevant to the first launch.

## **F-15 FIGHTER DATA LINK (FDL)**

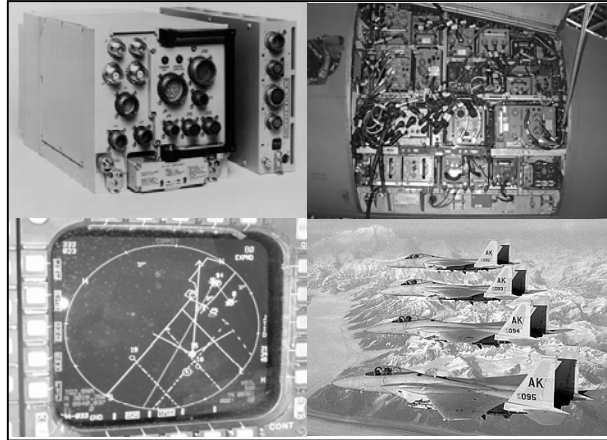

The Fighter Data Link (FDL), integrated into USAF and Air National Guard (ANG) F-15 fighters, provides improved situational awareness and sensor cueing in support of air superiority and interdiction missions. The FDL provides Link 16 data link networking with other Link 16 capable aircraft, command, and control systems. The FDL shares a number of components with the Multifunctional Information Distribution System (MIDS) terminal.

### **BACKGROUND INFORMATION**

The FDL was developed independently, but under the umbrella of the MIDS program and shares 30 percent commonality with MIDS. The FDL was designed to satisfy the USAF's "Urgent Need" for Link 16 data link in the F-15 fighter. The overall MIDS architecture is modular and additional capabilities, such as digital voice and imagery exchange can be inserted if required. The host platforms for the FDL are the ANG F-15A/B and USAF F-15C/D/E fighters. Initial Operational Test and Evaluation (IOT&E) was completed in FY00 and a Follow-On Test and Evaluation (FOT&E) was completed in FY01. The FDL was found to be operationally effective and suitable and it has been fielded to operational squadrons.

DOT&E encouraged increased information sharing and test support by FDL developers, users, and testers with the F-16 and F/A-18 MIDS integration efforts. This included lessons learned exchanges, technical advice regarding Link 16 integration, test design, and participation in test events. The F-15 FDL supported Navy F/A-18 MIDS and MIDS on Ships developmental test (DT) events.

### **TEST & EVALUATION ACTIVITY**

The one-year FOT&E ended in 2001. Its focus was reliability, integrated diagnostics Built-In Test (BIT), and logistics supportability.

## **TEST & EVALUATION ASSESSMENT**

The USAF has a requirement for 1,000-hour Mean Time Between Critical Failure (MTBCF) for the FDL. The FOT&E result is 963 hours MTBCF. While falling short of the 1000-hour requirement, the reliability exceeds the predecessor F-15 Class 2 Joint Tactical Information Distribution System reliability findings by approximately 400 percent. The BIT evaluation indicated that the F-15 Operational Flight Program (OFP) 3M is not suitable due to excessive False Alarms. OFP 4, planned for fielding in FY02, will provide a method for post-flight BIT data retrieval and the laboratory test OFP 4 with the enhanced BIT indicated a zero percent false alarm rate. Logistics supportability met the USAF specification, however AFOTEC has recommended increasing spares to allow for shipping delays to and from overseas deployment locations. This could add to FDL life-cycle costs. There were also deficiencies with the Interference Blanking System cable design and battery.

FDL-equipped F-15 aircraft supported F/A-18 MIDS-LVT-1 DT through participation in a common Link 16 network. While the F-15 FDL was generally interoperable on the Link 16 network with other Link 16 capable systems, there were F-15 FDL to F/A-18 MIDS message interoperability issues. This included difficulty in sharing engagement status and target contact information through Link 16 messages.

The F-15 FDL and F/A-18 MIDS fighter-to-fighter interoperability issues are a concern, particularly when Joint interoperability certifications have already been granted. OSD and Joint Staff Link 16 sponsors should review the deficiencies discovered, update message implementation standards if needed, and assign responsibility for correction. A joint operational verification test of both development and fielded legacy Link 16 host platforms is needed.

## **LESSONS LEARNED**

Lessons from F-15 FDL integration have proven valuable and have positively aided other MIDS integration efforts. All Service data link programs should be more aggressive in ensuring information is distributed to the Link 16 community and that a common problem resolution data base is created.



## **F-15 TACTICAL ELECTRONIC WARFARE SYSTEM (TEWS) (AN/ALQ-135 BAND 1.5)**

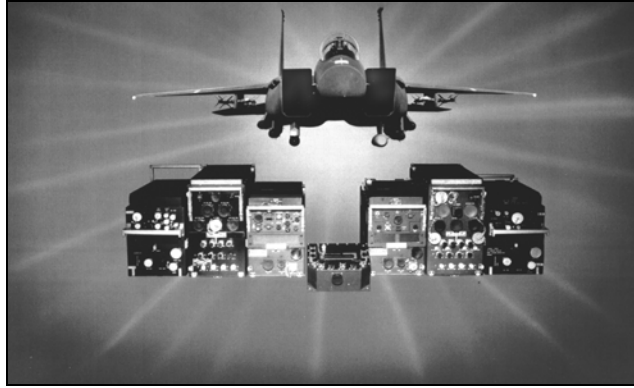

### **SYSTEM DESCRIPTION**

The F-15 Tactical Electronic Warfare System (TEWS) ALQ-135 Band 1.5 is an Air Force upgrade program that contributes to individual aircraft survival through improved air crew situation awareness of the radar guided threat environment, cueing both active and passive countermeasures in the Band 1.5 frequency spectrum, and adding a waveform select feature for jamming optimization against specific threats. TEWS consists of the ALR-56C radar warning receiver, the ALQ-135 internal countermeasures set, the ALQ-128 electronic warfare warning set, and the ALE-40/45 countermeasures dispenser. TEWS provides electronic detection and identification of surface and airborne threats and can provide active electronic jamming and dispensing of chaff and flares.

The ALQ-135 is an internally mounted responsive radio frequency jammer designed to counter surface-to-air and air-to-air threats with minimum aircrew activity. The Band 3 version of the ALQ-135 operates against threats at higher frequencies and has been fielded with the F-15E for over 11 years. It allows full interoperability and robust jamming techniques against modern Pulse-Doppler radar threat systems. The Band 1.5 improvement added the capability to operate against threats at lower frequencies. Band 1.5 is completely dependent on Band 3 for signal reception, processing, and interfacing with the rest of aircraft avionics. Future plans call for the integration of a Fiber Optic Towed Decoy (FOTD) to the existing TEWS system. The FOTD is based on Integrated Defensive Electronic Countermeasures (IDECM) technology and is currently scheduled for TEWS integration around 2005.

### **BACKGROUND INFORMATION**

DOT&E TEWS oversight began in November 1990. In 1994, AFOTEC conducted an Operational Assessment (OA) of the F-15E and concluded the system would not likely pass IOT&E. In 1998, the Band 1.5 DT phase began, but was encumbered by software immaturity and integration problems with Band 3.0. IOT&E was conducted May-July 1999 and included 38 open-air range test sorties with over 84 flight hours (103 operating hours). Numerous re-sets, BIT false alarms, and unexplained in-flight faults occurred and seven deficiency reports were written by AFOTEC. In October 1999, as a result of those deficiency reports, the AFOTEC commander de-certified the system from IOT&E, leading to the year 2000 Combined DT/OT and IOT&E (referred to herein as 2000 IOT&E). This effort consisted of Installed System Test Facility (ISTF) operations in the Preflight Integration of

Munitions and Electronics System (PRIMES) anechoic chamber at Eglin AFB, and a series of 55 open-air range sorties at the Eglin AFB Multi-Spectral Test and Training Environment and the Nellis AFB Test and Training Range. In-plant testing of the new Operational Flight Program (OFP) was conducted during the period November 1999-February 2000. Based on this testing (including a re-evaluation of BIT performance) at the Northrup Grumman facility in Rolling Meadows, IL, the ALQ-135 was re-certified to enter its year 2000 IOT&E.

The 2000 IOT&E consisted of ISTF operations in the PRIMES anechoic chamber and a series of 55 open-air range sorties at Eglin AFB and Nellis AFB, totaling 109 flight hours (137 operating hours). Fifteen of the 55 sorties were dedicated to evaluation of the system's contribution to reducing the lethality of surface to air missile systems. Additional test sorties were added as opportunities arose to evaluate effectiveness against air-to-air missile systems. Twenty-eight sorties were flown to assess suitability improvements. Three operational aircraft from Nellis AFB, as well as one Eglin AFB instrumented aircraft, participated in this test sub-phase. Twelve sorties were flown at Nellis AFB under operationally realistic conditions involving air-to-ground ordnance release and the use of chaff and maneuvers to accompany active ALQ-135 jamming.

### **TEST & EVALUATION ACTIVITY**

The only activity during FY2001 was the release of the DOT&E BLRIP report, discussed below.

### **TEST & EVALUATION ASSESSMENT**

DOT&E concludes that the system is operationally effective but not suitable (see the B-LRIP report to Congress dated December 2000 for more detail).

Results of the 2000 IOT&E indicate that the ALQ-135 is effective as measured by the system's capability to reduce the lethality of those SAM systems required by Air Combat Command. However, the ALQ-135 threshold criteria for effectiveness focused only on Band 1.5 and does not address the newer SAM systems. Effectiveness of the entire TEWS against air-to-air systems and its capability to engage multiple high duty cycle type threats remain to be evaluated. The addition of Band 1.5 equipment to the existing TEWS adds value to the self-protection capability of the F-15E and completes the TEWS suite as originally designed.

Reliability, Maintainability, and Operational Availability do not meet System Operational Requirements Document specified thresholds and objectives. Suitability of the ALQ-135 depends on the capability of the BIT to identify faults, enabling timely corrective action. The OFP changes made to improve BIT were ineffective; BIT false alarm rate is 65 percent. The BIT system for the ALQ-135 is the only means available for the aircrew to establish readiness of the system prior to entering a threat area. An excessive false alarm rate (e.g.,  $\geq 20$  percent) causes not only an unwarranted number of maintenance actions, but also distracts aircrew attention from primary mission functions.

Operational Availability (Ao) is a measure of the system's readiness for use when needed (uptime) as compared to total "ownership" time (uptime plus downtime). Ao was 80 percent based on Follow-On DT/OT data compared to the 63 percent estimate achieved during the 1999 IOT&E. The Air Combat Command objective for Ao is greater than 96 percent.

An additional shortfall with the TEWS system is a longstanding problem with the ALR-56C Radar Warning Receiver. In a dense signal environment, ALR-56C lacks adequate processing capability, as evidenced by incomplete and/or slow display of threat emitters to aircrews.

Because the Band 1.5 equipment adds an important capability, production was continued in spite of these shortcomings. BIT and reliability improvements, and Follow-on OT&E (FOT&E) are needed. The addition of a Fiber Optic Towed Decoy (Suite 5) will require a dedicated IOT&E. A full up, comprehensive ALQ-135 system level OT&E should be conducted prior to production and fleet release of the FOTD suite.

This Page Is Intentionally Left Blank

## **F-22 RAPTOR (ATF)**



The F-22 is an air superiority fighter designed to dominate the most severe battle environments projected during the first quarter of the 21<sup>st</sup> Century. Key features of the F-22 include low radar observability (with internal weapons carriage) and supersonic cruise capability in non-afterburning power, combined with superior maneuverability and excellent handling qualities. Other features critical to the F-22 concept of operations are wide field-of-regard offensive and defensive sensors, multi-spectral countermeasures, and high reliability, maintainability and supportability combined with enhanced deployability for worldwide operations. Basic armament consists of six AIM-120C radar-guided air-to-air missiles, two AIM-9 infrared guided missiles, and a 20mm cannon.

### **BACKGROUND INFORMATION**

The F-22 started as the Advanced Tactical Fighter (ATF) with Milestone 0 in 1983, Milestone I in 1986, and Milestone II in July 1991. Since then, the program has undergone several major changes due to schedule delays, budget reductions, and cost growth. An independent Joint Estimating Team identified significant cost growth in EMD and recommended program restructuring that was approved by a February 1997 DAB. A primary element of the restructure was elimination of the four Pre-Production Vehicles. As a result, two EMD test aircraft and two Production Representative Test Vehicles (PRTV 1) were assigned as OT test aircraft. EMD was also increased by nine months to allow more time for avionics testing. The EMD flight test program began on September 7, 1997, with first flight of aircraft 4001 at Marietta, GA.

In December 1999, a DAB delayed the LRIP decision and designated the next block of six aircraft Production Representative Test Vehicles II (PRTV II). It also provided long lead funding for LRIP Lot 1 (10 aircraft), and established the following exit criteria for the LRIP decision, then planned for December 2000:

- Complete avionics Block 3.0 first flight, initiating testing of Block 3.0 unique functionality.
- Complete first flight on EMD Aircraft 4003, 4004, 4005, and 4006.
- Complete static structural testing.
- Initiate fatigue life testing with the goal of completing 40 percent of first fatigue life.

- Conduct flight testing to include initiating RCS flight testing, initiating high angle-of attack testing with weapons bay doors open, and initiating separation testing of AIM-9 and AIM-120 missiles.
- Complete first portion of engine Initial Service Release (ISR) qualification test.

F-22 testing progressed slowly during CY 2000, mainly due to late aircraft deliveries. Only one test aircraft, of the five scheduled, was delivered to Edwards that year. In addition, aircraft deficiencies, including structural issues requiring onsite modifications and canopy problems, further delayed test progress. The December 2000 LRIP DAB was deferred to allow additional time to complete Exit Criteria. The F-22 TEMP was approved in January. In June 2001, to improve executability of the program, the Air Force again restructured the test program. The outcome was a reduction in testing across the avionics, flight sciences, and weapons integration areas and the deferral of some testing to beyond the start of IOT&E. In addition, the planned IOT&E start date was delayed from August 2002 to April 2003. All LRIP Exit Criteria were completed in February 2001 and the DAB was held in August 2001. Initiation of LRIP was recommended along with removal or adjustment of the previous F-22 production cost cap to reflect the \$5.4B increase in production. To compensate for the cost increase, production quantity was reduced from 331 (plus 8 production representative test vehicle aircraft) to 295 aircraft with the caveat that the Air Force could increase this quantity if production cost reduction programs yielded sufficient savings. Removal of the EMD cost cap was also recommended.

The F-22 live fire test (LFT) plan includes evaluation of hydrodynamic ram structural damage, dry bay fire, and critical component separation. Critical component separation reduces the possibility that a single hit will result in the loss of the aircraft. LFT in prior years included hydrodynamic ram vulnerability testing of the wing and aft fuel tanks, fire vulnerability testing of the wing attachment, aft side of fuselage, main landing gear (MLG), and airframe mounted accessory drive (AMAD) dry bays, and penetration vulnerability testing of avionics bays. High explosive threat effect tests were performed to evaluate component separation adequacy.

## **TEST & EVALUATION ACTIVITY**

Initial Service Release (ISR) accelerated ground testing of the F119 engine was completed in May 2001. F119 performance has generally been excellent throughout those portions of the flight envelope tested. However, the ferry range requirement is now projected as not achievable by a marginal amount due to actual specific fuel consumption. Additionally, some required mission/maneuver performance points may not be achievable with this engine. Full-scale airframe static testing has been completed but fatigue testing has been hampered by test fixture and attachment pad failures and only about one third of first fatigue life testing has been completed. Expansion of flight testing into the high-speed, high g-load regions of the performance envelope has begun. However, only one test aircraft incorporates the structural modifications and test instrumentation necessary to conduct this testing, which is crucial to expanding the allowable flight envelope for IOT&E and current aircraft operating limitations further increase schedule risk. Loads testing has been conducted in approximately 40 percent of the envelope. The ability to handle the load stress while performing at required maneuverability, especially asymmetric/rolling maneuvers, and fin buffet phenomena are areas of current known limitations. Structural limitations have been identified through static testing in regimes where flight testing at high load factors has not yet taken place. The program is also exploring candidate solutions to potential limitations found through flight testing in other regimes. Flight envelope expansion paces weapons integration and avionics testing since the flight envelope must be opened to complete necessary testing and prepare for IOT&E in those areas.

F-22 aircraft avionics flight test began in January 2001 with initial focus on validating installed radar performance. The APG-77 radar met detection range performance parameters, and radar testing continues in conjunction with the Communications, Navigation, and Identification (CNI) and Electronic Warfare (EW) subsystems that provide the other components of the integrated closed loop tracking. As a result of reductions in planned avionics test runs, the Flying Test Bed (FTB) is playing an even more essential role. The FTB consists of the radar in an F-22 forebody, spliced onto the nose of a Boeing 757 test aircraft, CNI components, EW components, and common integrated processors. It evaluates integration of avionics software and hardware components prior to their being installed and tested on the F-22. Used in concert with the Avionics Integration Laboratory, the FTB constitutes a key part of the process that culminates in F-22 avionics flight test.

Safe separation unguided missile launches were conducted with AIM-9 and AIM-120 unguided missiles. Testing revealed a “q bias” problem in the AIM-120 software. The q bias provides a command to the AIM-120 flight control system to ensure that the missile safely separates from the aerodynamic flow field surrounding the launch aircraft. A modified q bias command was developed and tested and has resolved this issue. Initiation of guided missile testing revealed a boresight problem in the current software that will be corrected in the next planned major software update. The first guided AIM-120C launch from the F-22, a CY 2001 exit criterion, occurred in September 2001 with the missile guiding to within lethal radius of the target. Though it was not conducted at TEMP required operational shot parameters, the event was a successful developmental test and highlights the need for continued guided, end-to-end missile testing.

Testing of F-22 stealth characteristics has included measurements of both radar and infrared signatures and initiation of stability over time and logistics testing. Stealth sustainability testing is in progress and the first of several planned 50-hour LO maintenance test blocks have been completed. Environmental risks in the LO area have been reduced and maintenance processes for restoration of RCS have been developed.

DOT&E provided inputs to the Defense Acquisition Executive on CY 2002 exit criteria for the F-22 program. The inputs emphasized performance based criteria with relevance to readiness to enter the IOT&E early in the following year. Some exit criteria have been selected and final resolution of all criteria will take place at a quarterly program review in early 2002.

## **TEST & EVALUATION ASSESSMENT**

The 1991 Milestone II DAB directed an Operational Assessment (OA) to support the F-22 LRIP decision. The Air Force conducted OA began in January 1998 and the report documenting results was published in April 2001. Numerous issues including main landing gear strut settling, environmental control system problems, intra-flight data link shortfalls, and missile launch detector performance were identified. Aircraft brake and arresting tail hook design difficulties were highlighted as creating a potential for the F-22 to be forced to operate from longer airfields. While none is planned, if specialized LO related support equipment is required, it could adversely affect mobility support requirements. The greatest risks to certification of the F-22 for IOT&E were identified as avionics test progress, software development, flight envelope expansion, and test aircraft configuration. DOT&E concurs in this assessment.

The revised F-22 test program has many ramifications. In the avionics area, the number of planned flight test runs was reduced by about half by combining various objectives into single test runs.

In the flight sciences area, some aspects of flight envelope expansion were deferred to after the start of IOT&E and previously planned test program content was reduced. The Air Force also reduced and restructured the planned F-22 weapons integration test program by deferring AIM-9 testing under rolling launch conditions. Additionally, they proposed to reduce the number of TEMP-required guided missile test scenarios. The Air Force intends to demonstrate that the captive-carry instrumented test vehicle (ITV) version of the AMRAAM missile is a valid OT evaluation tool — which may result in fewer guided missile launches being accomplished. The TEMP was revised to reflect the option to use ITV data in lieu of actual live launches in certain scenarios if approved by DOT&E. The initial missile test launch was conducted at non-operationally realistic (slower) airspeeds as an engineering build-up to TEMP scenarios. This was due to the slower than expected pace of flight testing in flight sciences envelope expansion. Some fully integrated guided missile test launches required by the TEMP will be done concurrently with IOT&E or as part of a post-EMD effort. DOT&E believes that the largest F-22 development risk, from both a technical and a schedule perspective, lies in the integration and validation of the advanced avionics suite with realistic air-to-air weapons employment.

Only one F-22 flight test aircraft incorporates the structural modifications and special instrumentation to enable the flight envelope to be fully cleared to its airspeed, altitude, and g-load design limits. This situation poses a high schedule risk in clearing the required flight envelope prior to IOT&E. Completion of the highly concurrent, integrated avionics system test plan also presents a significant challenge. Problems exist with CNI, EW, and integrated avionics. All have been hampered by lack of stability and difficulties getting software upgrades loaded onto test aircraft. Elimination of previously planned build-up test runs increase the probability that the avionics suite may enter IOT&E with unresolved and unrecognized anomalies. If redesign to meet performance thresholds is required, the current schedule may not allow sufficient time to incorporate and validate modifications prior to IOT&E.

Based on testing conducted to date, F-22 stealth parameters are meeting required capabilities. However, flight test with production representative finishes has yet to begin and a significant amount of RCS stability over time, environmental and sustainment testing remains to be completed. Remaining logistics tasks involve maintenance of F-22 stealth capabilities under sortie generation rate conditions. Availability of the Integrated Maintenance Information System (IMIS) is essential for IOT&E as are production representative aircraft and support equipment.

The F-22 Air Combat Simulator (ACS), an integral part of the planned IOT&E, will model the dense surface-to-air and air-to-air threat and electronic signal environment that is impractical or too costly to generate in open-air tests. Development of the ACS, consisting of two domes and ten manned interactive cockpit stations, continues but recent reductions in planned avionics flight test affects Verification, Validation and Accreditation (VV&A) activities, necessary prior to initiation of IOT&E. The planned flight test program will not provide all data required for accurate ACS system characterization. FTB and ground hardware-in-the-loop laboratory data will be used to supplement flight test data in the ACS VV&A effort.

Wing fuel tank hydrodynamic ram tests were conducted in FY01 using aircraft 4001 and leading edge dry bay fire ballistic tests will occur in FY02. Fuel tank inerting tests will use a fuel system simulator to evaluate the on-board inert gas generating system. Fuselage fuel tank hydrodynamic ram damage ballistic testing is also planned for FY02 and a realistic forward fuselage test article has been manufactured for this test. The Air Force relaxed the vulnerability requirement to accommodate increases in vulnerability determined as a result of LFT. Based on completed testing, the current F-22 design meets the new specification for vulnerability.



DOT&E supported relief from EMD cost caps for the F-22 program. Continuing the cap would limit required testing and potentially prevent the Service from implementing corrections for known deficiencies. To prepare for and execute an adequate IOT&E, the Service needs to be able to channel sufficient resources to find mission affecting problems and correct them. An EMD cost cap would hinder that effort.

This Page Is Intentionally Left Blank

## GLOBAL BROADCAST SERVICE (GBS)

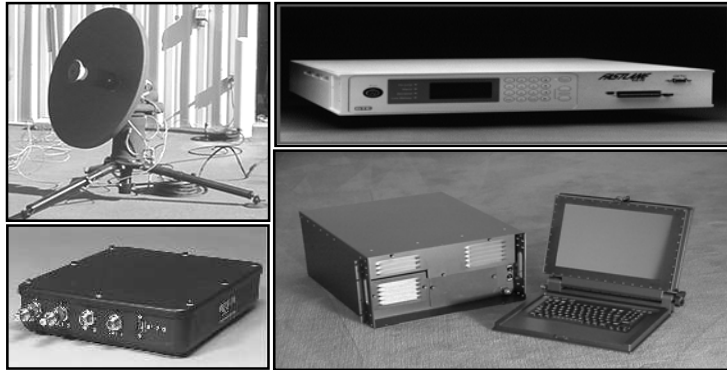

The Global Broadcast Service (GBS) will augment and interface with other communications systems and provide a continuous, high-speed, one-way flow of high-volume data, audio, imagery, and video information streams at multiple classification levels to deployed and garrisoned forces across the globe.

GBS consists of a space segment, fixed and transportable transmit suites, and fixed and transportable receive suites. The space segment of the current phase of GBS consists of four GBS transponders on each of three Ultra High Frequency Follow-On (UFO) satellites and leased commercial satellite transponders as required to meet demand. Transmit suites build broadcast data streams from various sources of information, including command, weather, and intelligence agencies and commercial television programming. They manage the flow of selected information through the uplink broadcast antenna to the orbiting satellites for broadcast to the appropriate theaters of operation. The receive suites extract the appropriate information for distribution by existing systems to the appropriate end users within selected areas of operation.

### **BACKGROUND INFORMATION**

The GBS acquisition strategy was conceived as a three-phase program based on an evolutionary system design supported by commercially available technology. The program is currently in Phase II. GBS Phase I, conducted from FY96 to FY98, was used to develop the user requirements and concepts of operations. GBS Phase II, scheduled for completion in FY06, will develop near-worldwide GBS core operational capability and further refine operational requirements and employment concepts. GBS Phase III, scheduled to begin in FY06, is being addressed as part of the Advanced Wideband System (AWS) program.

Technical problems with transmit suite software and transportable and fixed receive suite design and subsequent program delays led to a JROC decision to defer a small subset of capabilities, field the system with non-deferred capabilities, and then incrementally field upgrades until all the ORD thresholds are met. Commercial technology that can assist in satisfying the deferred capabilities is now becoming available, but this could require some significant changes in the system architecture.

The system was incrementally fielded with successive software builds during FY01. The deferred capabilities of full broadcast history, classified video, and remote enable will be fielded in two

additional builds with an IOC for this upgraded capability projected for 4QFY02. Finally, the more lightweight rugged Transportable Ground Receive Station (TGRS) configuration will be released in FY03, with an IOC for this configuration projected for 4QFY03.

### **TEST & EVALUATION ACTIVITY**

An updated Phase II TEMP is in coordination that reflects the incremental fielding and testing requested by the JROC and the May 2001 revised Operational Requirements Document (ORD). AFOTEC has briefed DOT&E on the operational test approach. A Combined Test Force was formed to coordinate the planning of all GBS testing. Combined DT/OT #1 was conducted in January 2001 at contractor and government developmental facilities on the U.S. east coast. Contractor developmental test events have included factory acceptance tests, Satellite Broadcast Manager (SBM) site acceptance tests, Y2K tests, shipboard receive suite tests, and on-orbit tests of UFO satellites 8, 9, and 10. DT/OT #2 was conducted in June 2001 in the Pacific Theater.

### **TEST & EVALUATION ASSESSMENT**

During DT/OT #1, the SBM was successful in building daily broadcast schedules and beam plans as well as in broadcasting video, audio, and File Transfer Protocol (FTP) classified and unclassified products. However, the Transmit Planning and Scheduling (XPS) software was immature and several problems were identified for correction. The Receive Broadcast Managers (RBMs) were able to receive video, audio, and FTP classified and unclassified products. However, there were observed inconsistencies with product reception successes among RBM sites. In general, all RBM sites were able to maintain good signal lock during Ka and Ku broadcasts; however, there were serious observed failures with scheduled product reception.

The SBM software used in DT/OT #2 was vastly improved from its performance during DT/OT #1; however, it was still immature and several new deficiencies were identified. The RBMs were able to receive video, audio, and FTP secret, ROKUS, and unclassified products. DT/OT #2 and DT/OT #1 were very similar in that, at both test events, an inconsistency with product reception success was observed throughout the test sites.

Looking ahead to MOT&E, users need to finalize their CONOPS before the GBS system will be able to enter testing. AFOTEC will not test without a CONOPS. Additionally, the program office must ensure timely installation of the Key Performance Parameter required satellite beam control terminal at the Sigonella SBM prior to MOT&E.

## JOINT AIR-TO-SURFACE STANDOFF MISSILE (JASSM)

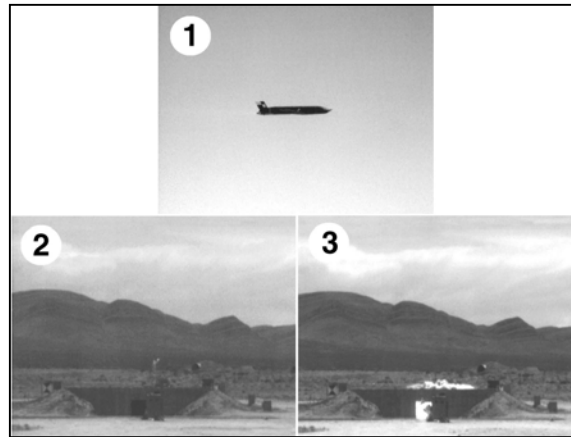

The Joint Air-to-Surface Standoff Missile (JASSM) is precision cruise missile capable of launching from outside area defenses to kill hard, medium-hardened, and soft/soft-distributed targets. It is required to attack fixed and relocatable targets and uses an Inertial Navigation System/Global Positioning System for en route navigation and an Imaging Infrared (IIR) seeker for precision terminal guidance. Threshold integration aircraft are the F-16 (Block 50) and B-52H. Key Performance Parameters (KPPs) are: Missile Mission Effectiveness (MME) (measure of ability to kill a defined target set), Interoperability, Aircraft Carrier Operability and Missile Range. Funding issues and F/A-18 E/F test platform availability will prevent carrier operability from being evaluated during IOT&E. To avoid delay in AF deliveries, the Joint Requirements Oversight Council approved deferral of this KPP until after the Milestone III full-rate production decision in 4QFY03. Integration on the F/A-18 E/F will also be delayed until 4QFY03.

### **BACKGROUND INFORMATION**

In June 1996, during the Program Definition-Risk Reduction phase, Congress directed the AF and Navy to perform an updated Analysis of Alternatives to determine the relative value of JASSM versus a proposed variant of the Navy Stand-Off Land Attack Missile-Expanded Response Plus (SLAM-ER+). The result was a substantiated requirement for JASSM, which the Secretary of Defense certified to Congress in April 1998.

A November 1998 Milestone II decision approved entry into EMD and the LRIP entrance criteria, and funded a 6-month EMD extension to reduce program risk. As a result, LRIP moved to January 2001 and Milestone III moved to July 2002. In September 1999, SAF/AQ directed the JASSM program office to further re-structure the schedule and delay LRIP from January 2001 to December 2001. This second delay was driven by technical problems and changes to the engine. Outer missile mold line changes were also required due to anomalies discovered during jettison testing.

Flight-testing began in FY00 with a prototype pre-production flight test vehicle, launched from an F-16. The first launch of a production configuration All-Up Round (AUR) was in September 2000. After completing 25 percent of the mission, the missile impacted the water after a premature engine flameout, caused by a malfunctioning fuel control valve, which has been redesigned. Flight-testing also included releasing jettison test vehicles from the F-16 and B-52. Additionally, over 80 captive carry

flights of the IIR seeker were conducted using production JASSM navigation and seeker hardware in a pod mounted externally on a helicopter.

The JASSM test strategy includes: (1) early OT involvement; (2) early and continued use of modeling and simulation to gain T&E efficiencies; (3) DT to reduce the operational test matrix, and (4) operational units in T&E to minimize training time when JASSM is fielded. The program is based on contractor run DT that the government supports with test aircraft, ranges, and instrumentation. The DT program supports combined DT/OT requirements and will lead to independent government IOT&E. The approved LFT&E strategy for JASSM calls for the lethality evaluation to be derived from contractor-conducted tests and combined DT/OT and IOT&E attacks.

In December 2001, JASSM was approved for entry into LRIP and the program was designated as an ACAT 1C. As a result, the Air Force is the lead service for the Full-Rate Production, Milestone III decision, which is scheduled for 4QFY03. The AF plans to buy 3,700 units in a 13-year period. Navy quantities are still to be determined. Peak rate production is planned for 360 units per year.

### **TEST & EVALUATION ACTIVITY**

JASSM warhead sled testing was completed in FY01. In late 2000, two bare warhead sled tests were conducted, and both detonated correctly after perforating reinforced concrete targets. Following these, two AUR sled tests were conducted with warheads in wingless JASSM missile bodies. Both tests were successful. Although the approved TEMP originally planned for four AUR sled tests, the contractor, with DOT&E approval, ended the sled testing, retaining the remaining two assets as a contingency in the event future sled testing was required during DT/OT.

DT began in 2001 with a successful launch and inert warhead delivery. The next four flight tests were with live warheads against representative threat targets. The first attacked a communications van and the second, a thin-roof concrete bunker. Both were destroyed. The third live test was to achieve a surface burst of the warhead against a radar site. Although the missile was accurately delivered, the warhead failed to detonate because the fuze did not arm. The fuze was recovered, analyzed, and corrective measures were taken. The fourth live test was to attack the radar site again, in order to validate the fuze corrective actions. This test experienced an arming problem and a failure of the warhead to detonate. Following this second failure, a fuze and arming system modification was incorporated that was flown on the following two DT flight tests. This modification successfully demonstrated fuze arming and warhead detonation on both soft distributed and hardened targets.

### **TEST & EVALUATION ASSESSMENT**

There are *three areas of concern*. *First*, the models and simulations intended to predict missile behavior during launch/aircraft separation have not performed as expected. The program includes test events to validate the models and determine the aircraft envelopes using those models. Test results have not correlated well with the model and the results have significantly reduced the operating envelope. The Program Office is working with Air Combat Command to determine whether to conduct additional modeling and testing to validate/update the model or accept the reduced operating and employment envelopes. *Second*, JASSM integrates complex multiple mission-planning components into a single mission planning system to meet user needs. The program has not yet demonstrated this capability, but must before OT can begin. The Program Office is working aggressively with AFOTEC to resolve the

mission-planning deficiencies. *Third*, the Missile Mission Effectiveness KPP will be evaluated against a JROC target set of 17 targets. However, not all of these targets will be attacked/destroyed. Instead, MME will be derived employing models validated using test data from a small subset (6-7) of the target set. These models are immature and their ability to describe real behavior is yet unknown. Therefore, the ability to predict MME and lethality will continue to be monitored closely by DOT&E.

Overall, the JASSM program is on track. Launch, guidance, and control systems performance has been excellent. Program difficulties are being addressed in an open and cooperative environment. From these, DOT&E offers the following lessons. *First*, early OTA and DOT&E involvement has significantly reduced risk in the upcoming OT phase. In addition, this early OT involvement has helped the DT team to consider future OT requirements in their testing. This cooperation will enable the OTA to incorporate some DT data in Operational Assessments. *Second*, coordination with other defense agencies successfully provides realistic representative targets during live missile flights. This so far has provided a clear indication of the warhead's lethality against intended targets when accurately delivered and properly fuzed. However, unknowns remain regarding targets in the set that have not yet been attacked or will never be attacked during testing. *Third*, these unknowns highlight the need for the modeling effort to be closely monitored and validated with an appropriate number of data points.

This Page Is Intentionally Left Blank



## **JOINT DIRECT ATTACK MUNITION (JDAM)**

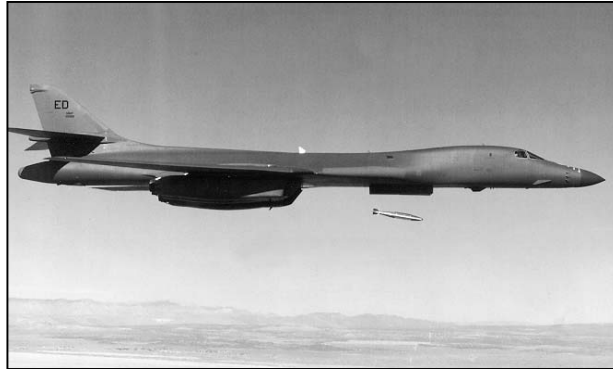

The Joint Direct Attack Munition (JDAM) is a low cost, autonomously controlled, adverse weather accurate guidance kit for the Air Force/Navy 2,000-pound MK-84 and BLU-109 general-purpose bombs and the 1,000-pound MK-83 and BLU-110 bombs. The JDAM tail kit will also be adapted to the MK-82 500-pound bomb. There are no planned design changes to the bombs (casing metallurgy, explosive fill, fusing mechanism, etc.), but the existing inventory weapons will be configured with JDAM guidance kits and accessories. The guidance is accomplished via an Inertial Navigation System (INS) aided by Global Position System (GPS). Actual weapon launch will occur when the aircrew has flown the aircraft into the weapon Launch Acceptability Region (LAR). The LAR is the three-dimensional volume in space in which the weapon may be released to fly either directly to a selected target or on a pre-determined bearing.

The JDAM kit yields delivery accuracy of less than 13 meters when GPS is available and less than 30 meters when GPS is absent or jammed after release. JDAM is employed by a variety of fighter/attack and bomber aircraft, allowing precision engagement from all altitudes under adverse environmental conditions. The primary aircraft for integration and operational testing of the 2,000-pound JDAM were the B-52H and the F/A-18C/D. The F-16, B-1, and B-2 are also operational users of JDAM. The 1,000-pound JDAM will be tested and integrated initially on the F/A-18C/D, AV-8B, and F-22. The 500-pound JDAM will be tested and integrated initially on the F/A-18C/D and B-2.

### **BACKGROUND INFORMATION**

The April 1997 JDAM LRIP decision approved the procurement of approximately 1 percent of the total planned buy. In January 1998, USD(A&T) approved the delay of Milestone III to 3QFY99, and added a second LRIP for JDAM. In May 1998, the LRIP II decision approved the procurement of additional 2,000-pound MK-84 kits. In December 1998, USD(A&T) approved delay of Milestone III until 1QFY00. This was due to investigation of a bending fatigue problem discovered in the high-speed, low to medium altitude environment, resulting in cracks in the fin shafts in MK-84 tail assemblies carried on the inboard stations of the F/A-18C/D, and added a third LRIP for JDAM. Further delays in completing the development and flight testing of the new pin-lock tail actuator sub-system design necessitated an additional delay for Milestone III. In June 2000, USD(AT&L) approved further delay of Milestone III until April 2001 and approved the pin-lock configuration for a fourth LRIP for JDAM. This decision also added the F/A-18C/D as a threshold aircraft for the MK-83 due to software development delays for the AV-8B. The LRIP weapons comprise approximately 18 percent of the

planned total quantity. A waiver for exceeding 10 percent of the planned total procurement during LRIP was approved prior to the LRIP IV decision. Milestone III was approved in March 2001.

Live Fire Test and Evaluation of JDAM was not required because the lethality and survivability of both the MK-84 and BLU-109 bomb bodies were well documented.

### **TEST & EVALUATION ACTIVITY**

Integration testing of the 2,000-pound JDAM on additional platforms, including the F-14 and F/A-18E/F, continues.

DT of 1,000-pound MK-83 is complete. An operational assessment of the DT results was accomplished. F/A-18C/D dedicated OT of the MK-83 is planned to begin December 2001. The scale of testing is expected to be less than testing for the 2,000-pound variants due to the high commonality of already tested components. Integration testing on the F-22 is planned to begin in FY02.

Developmental flight test is projected to begin for the MK-82 500-pound bomb on the F-16 and F-18C/D in 3QFY02 followed by operational flight testing in FY03.

### **TEST & EVALUATION ASSESSMENT**

JDAM completed operational testing of the MK-84 and BLU-109 2,000-pound variants in August 2000. The operational testing was adequate to evaluate the operational effectiveness and suitability of the JDAM 2,000-pound class kit. Results were reported in the Operational Test and Evaluation Report in March 2001.

JDAM is operationally effective only in combination with existing fuzes, the FMU-139 and FMU-143, used by MK-84 and BLU-109 weapons. Testing was not completed with the FMU-152 Joint Programmable Fuze due to numerous arming failures and subsequent decertification of FMU-152/JDAM combinations for both Air Force and Navy use. The accuracy of the weapon, in GPS-aided and INS-only modes, and against both horizontal and vertical targets, exceeded requirements with high confidence. However, because of container durability, system reliability, and failure to meet mission planning timelines, JDAM capability as integrated with delivery platforms and other system components was assessed as not operationally suitable. Although improvements were demonstrated during the test period, deficiencies remain that will affect operational employment. However, the high degree of effectiveness and substantial increase in targeting and weapon delivery flexibility were sufficient to justify fielding of the JDAM weapon system.

To address the unresolved and unsatisfactory issues from IOT&E: a dedicated FMU-152 Joint Programmable Fuze/JDAM follow-on operational test and evaluation (FOT&E) is planned, and the redesigned container and system reliability will continue to be tracked and evaluated through FOT&E and lot acceptance testing. Mission planning time should not adversely affect JDAM effectiveness, but will be evaluated during FOT&E and MK-83 OT.

Six DT&E MK-83 weapons were dropped with effectiveness results sufficient for the program office to declare the DT phase complete and ready for FOT&E. A joint OT Readiness Review concurred in December 2001.

## JOINT HELMET MOUNTED CUEING SYSTEM (JHMCS)

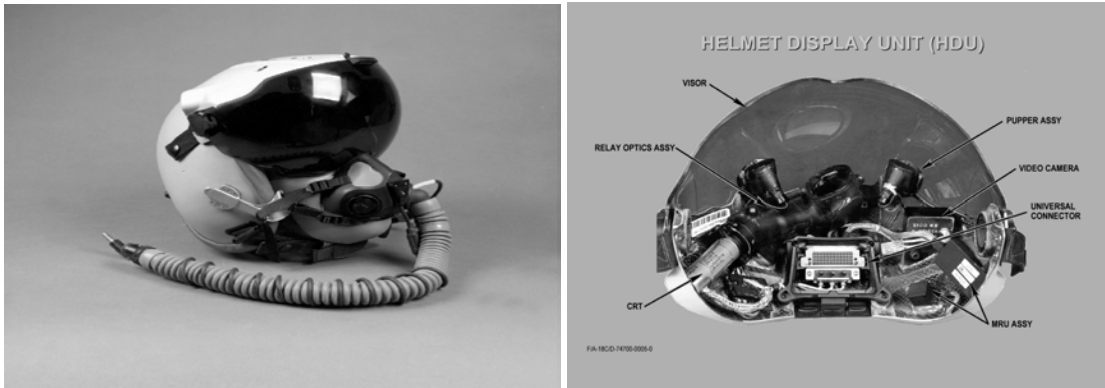

The Joint Helmet Mounted Cueing System (JHMCS) is a modified HGU-55/P helmet that incorporates a visor-projected Heads-Up Display (HUD) to cue weapons and sensors to the target. This new cueing system improves effectiveness in both Air-to-Air and Air-to-Ground missions. In close combat, a pilot must currently align the aircraft to shoot at a target. JHMCS allows the pilot to simply look at a target to shoot. This system projects visual targeting and aircraft performance information on the back of the helmet's visor, enabling the pilot to monitor this information without interrupting his field of view through the cockpit canopy. The system uses a magnetic transmitter unit fixed to the pilot's seat and a magnetic field probe mounted on the helmet to define helmet pointing positioning. A Helmet Vehicle Interface (HVI) interacts with the aircraft system bus to provide signal generation for the helmet display. This provides significant improvement for close combat targeting and engagement.

The JHMCS system will be employed in the FA-18C/D/E/F, F-15C/D, F-22 and F-16 Block 40/50, with a design that is 95 percent common to all four platforms. When used in conjunction with an AIM-9X missile, a pilot can effectively designate and kill targets in a cone more than 80 degrees to either side of the nose of the aircraft or High Off-Boresight (HOB).

### **BACKGROUND INFORMATION**

A Joint Mission Needs Statement for JHMCS was signed in January 1994, with a Milestone II decision to enter EMD in December 1996. A Navy Operational Assessment (OA) began in August 1999 and was completed in February 2000, resulting in Low Rate Initial Production (LRIP) approval in May 2000. A joint OA concluded in August 2000 and supported a LRIP-2 decision in May 01. An LRIP-3 decision is scheduled for April 2002 after completion of Initial Operational Test and Evaluation (IOT&E) with a full-rate production decision planned for August 2002. The system is scheduled to reach IOC for the F/A-18E/F and F-15C in FY03, the F-16 by FY04.

### **TEST & EVALUATION ACTIVITY**

Despite some concerns with system maturity, DOT&E approved the JHMCS Test and Evaluation Master Plan and the USAF and USN initial operational test plans for the system. Initial Operational Test and Evaluation of JHMCS began in June 2001 for the USAF and October 2001 for the USN.

## **TEST & EVALUATION ASSESSMENT**

Initial DT results using the FA-18C/D and F-15C found significant reliability and maintainability issues (particularly with the FA-18C/D) with the connector between the helmet and the aircraft, the HVI. It was also recommended that pilot training adequately address visor focal length issues and cockpit scan practices prior to flying with the new helmet. The Operational Assessment reported the JHMCS on the FA-18C/D as potentially effective and potentially not suitable due to numerous breaks in the HVI with long fix times and a high false alarm rate by the built-in test equipment. Initial F-15C flight tests found that the legacy computer throughput provided slow support to the JHMCS. This computer latency problem, coupled with the F-15C high buffet, affected target designation performance.

Efforts to correct HVI reliability included replacing an unreliable coaxial cable with a different form of shielded wiring. Unexpected in-line release connector disconnects were corrected by re-routing the cable and adding an exo-shell to eliminate side load effects within the cockpit. The FA-18E/F maintainability issue was corrected by re-designing the connector to allow the ability to re-mate, as in the F-15C connector, and to provide limited organizational-level repair capability. On the USAF F-15 platform, the system is performing well with respect to effectiveness, but reliability has been poor. Mean time between failures is falling well short of the operational requirement threshold value. Our assessment of the results of this on-going OT&E will be reported in the 2002 Annual Report.

Since these initial tests, several corrective designs have been introduced that should improve reliability to an acceptable level of performance. DOT&E's assessment is ongoing and will be reported upon completion of initial operational test and evaluation.

The Joint Helmet Mounted Cueing System was the subject of a DoD/IG audit, initiated in June 2000. The draft DoD/IG report identified shortcomings in the proposed OT test plans to include a lack of clearly-defined quantitative measures of performance and pass/fail criteria as well as an inadequate sample size leading to poor statistical significance. Working in concert with DOT&E, the operational test agencies identified and implemented corrections to the test plans. The final DoD/IG report deemed the revised plans to be acceptable.

## **JOINT PRIMARY AIRCRAFT TRAINING SYSTEM (JPATS)**



The Joint Primary Aircraft Training System (JPATS) is a set of primary flight training devices tailored to meet U.S. Air Force (USAF) and U.S. Navy (USN) aircrew requirements. The principal JPATS mission is to train entry-level USAF/USN student pilots in primary flying skills to a level of proficiency at which they can transition into an advanced pilot training track leading to qualification as military pilots, navigators, and Naval Flight Officers. JPATS is designed to replace the USAF T-37B and USN T-34C aircraft and their associated Ground-Based Training Systems (GBTS).

The JPATS consists of the T-6A Texan II air vehicles, simulators and associated ground-based training devices, a training integration management system, instructional courseware, and contractor logistics support. The Services will acquire common aircraft and the remaining components will be as common as possible. Logistics support will be tailored to each Service's maintenance concept.

### **BACKGROUND INFORMATION**

In December 1990, the Joint Requirements Oversight Council validated the JPATS Mission Need Statement. Operational requirements were subsequently codified in the JPATS Operational Requirements Document (ORD). JPATS was designated a Defense Acquisition Pilot Program in the 1994 Federal Acquisition Streamlining Act, becoming the first aircraft program to be selected.

An early operational assessment was conducted during the Source Selection Flight Evaluation from July-October 1994 at Wright Patterson AFB. Seven candidate aircraft were evaluated, each completing 13 flights. Milestone II was held in August 1995, and the Raytheon Corporation was awarded a contract for engineering and manufacturing development. Following a source selection process conducted by Raytheon, the GBTS subcontract was awarded to the Flight Safety Services Corporation in April 1997.

MOT&E(I), an in-plant operational assessment (OA) of the GBTS, was performed in September 2000. Eighty-three deficiencies were identified and one safety issue was highlighted which has been subsequently corrected.

The AFOTEC test team has been on-site at Randolph AFB conducting MOT&E(A) for the T-6A and in the Flight Safety plant conducting MOT&E(I) for the aircrew training devices. MOT&E(A) consisted of approximately 300 flight hours flown by experienced instructor pilots from the USAF and

USN using commands (Air Education and Training Command (AETC) and CNATRA) and operational test pilots from AFOTEC and COMOPTEVFOR. The Joint Primary Pilot Training (JPPT) course syllabus was the basis for mission profiles. Common student errors, those mistakes made by inexperienced students, were employed to determine the viability of the T-6A as a primary student trainer. In addition, deficiencies identified in previous tests were re-evaluated. MOT&E (A) commenced in June 2000. Testing was completed in November 2000. The MOT&E(A) report concluded the aircraft to be effective, not suitable and had safety issues to include the environmental control system and the UHF radio.

The last approved TEMP was in January 1999. The TEMP was revised to reflect changes in the ORD, delays in the development and production schedules, and updated GBTS information following selection of a GBTS contractor Flight Safety Systems. That revision contained a more detailed plan for testing the requirements of all GBTS components and the full range of air vehicle missions described in the ORD. The January 1999 TEMP requires an update to support the Milestone III production decision.

### **TEST & EVALUATION ACTIVITY**

DOT&E supported numerous IPTs and TEMP meetings in preparation for the November 2001 Milestone III production decision. The MOT&E(S) test plan is in work and will be submitted prior to the scheduled test in June 2002.

Testing of a new design for the environmental control system was completed. Initial tests on one modified aircraft in a non-representative environment suggest adequate cooling could be available for student training at bases with high heat and humidity. During previous testing, adequate cooling of the cockpit had not been demonstrated using a production-representative system in typical operational environments nor did it meet system specifications. Cockpit temperatures near 100 degrees fahrenheit have been recorded. Four problems are being examined: (1) rapid system cycling; (2) distribution of air in the cockpit areas; (3) reducing the temperature of cooled air; and (4) improving control of louvers for directing airflow. Production cut-in is expected in the spring 2002.

Testing for the UHF radio is not completed, however, a potential solution has been partially tested. Operational testing will be conducted when the system is ready.

The System Level Formulative Evaluation for the integrated GBTS components started in January 2001. It evaluated, for the first time, whether the suite of JPATS GBTS components has the capability to operate as an integrated system. This represents the first opportunity to evaluate, in part, the integrated JPATS, including the aircraft and GBTS, from an operational perspective minus actual students. A number of discrepancies were documented and still need to be resolved.

The Training Information Management System is not ready for operational testing. However, the OT team has supported developmental testing.

### **TEST & EVALUATION ASSESSMENT**

The JPATS Beyond Low Rate Initial Production report was published in November 2001. As tested and currently configured, the aircraft was operationally effective with numerous limitations, deficiencies, and workarounds and not operationally suitable. In addition, several safety issues were identified to be addressed and sufficiently rectified. Problem areas included the engine, ECS, UHF and

VHF radio performance, flight manuals and checklists, the emergency oxygen system, ground egress, the trim systems, the power control lever, the wheel brakes, cockpit storage, and rear view mirrors.

In addition, the aircraft breaks more often and takes longer to repair than predicted. That impacts the sortie generation rate, which affects cost, manpower and student training.

This Page Is Intentionally Left Blank



## JOINT STRIKE FIGHTER (JSF)



The Joint Strike Fighter (JSF) Program will develop a family of strike aircraft, capitalizing on commonality and modularity to maximize affordability while addressing the needs of the Air Force, Navy, Marine Corps, and United Kingdom Royal Navy and Royal Air Force. This family of strike aircraft will consist of three variants: (1) Conventional Takeoff and Landing; (2) Aircraft Carrier Suitable; and (3) Short Takeoff and Vertical Landing (STOVL). The focus of the program is affordability: reducing the development, production, and ownership costs of the JSF family of aircraft. The family of JSF variants will provide the Navy with a first-day-of-the-war, survivable aircraft to complement the F/A-18E/F; the Air Force with a replacement for the F-16 and A-10 and complement the F-22; the Marines with a single STOVL platform to replace the AV-8B and F/A-18C/D; and the Royal Navy and Royal Air Force with a supersonic STOVL fighter/attack aircraft to replace the Sea Harrier and GR-7, respectively.

The JSF will be a single-seat, single-engine aircraft capable of performing and surviving lethal strike warfare missions using an affordable blend of key technologies. A high degree of commonality (70-80 percent) exists amongst the three variants. Aircraft sub-systems that will be identical in all three designs include the wing and fuselage structures, engine core, avionics and onboard computers, cockpits, electrical wiring, electronics, flight controls, control surfaces, and fuel tanks. The JSF system consists of the JSF air vehicles and all support training equipment, related facilities, materiel, software, services, and personnel to ensure that the system can accomplish its intended operational role.

### **BACKGROUND INFORMATION**

A multi-year \$2.2 billion JSF Program Definition and Risk Reduction (PDRR) effort commenced in November 1996, with competitive contract awards to Boeing and Lockheed Martin for the PDRR Program. These competing contractors each built two concept demonstrator flight test aircraft to conduct concept-unique ground demonstrations and continue refinement of their ultimate delivered weapon system concepts. Pratt & Whitney provided propulsion hardware and engineering support for both Boeing's and Lockheed Martin's JSF PDRR efforts. The JSF Alternate Engine Program with General Electric continues to develop an alternate engine for production in order to reap the financial and performance benefits of competition. On October 26, 2001, the Lockheed Martin team was announced as the winner of the competition.

The System Development and Demonstration (SDD) phase, which follows PDRR, is structured to develop the JSF weapon system in a series of block upgrades with successively increasing capabilities. The first three blocks are intended to achieve the full performance capabilities currently set forth in the Joint Operational Requirements Document. As SDD progresses, the users are expected to require new capabilities for future block upgrades as the strengths and weaknesses of various emerging technologies become apparent.

The JSF program qualifies as a covered program requiring both lethality and vulnerability Live Fire Test and Evaluation (LFT&E). The overall JSF LFT&E strategy includes full-up, system-level Live Fire Vulnerability Tests of one aircraft variant and Live Fire Lethality Tests of the new gun and ammunition.

DOT&E approved the JSF Alternative LFT&E Plan on August 3, 2001. A waiver from full-up, system-level testing for the other two variants has been requested by the JPO. Due to the high degree of commonality between variants, the data from the full-up, system-level Live Fire Tests of an SDD air vehicle will provide a considerable amount of information needed to evaluate the survivability of the other two variants. Live Fire Tests of variant-unique components and features will be accomplished by using a drop-test article, full-scale propulsion systems, large assemblies, and components. The plan also requires extensive Live Fire testing of the engine.

The JSF LFT&E strategy also includes realistic, end-to-end lethality tests of the new gun system. The gun lethality LFT&E Program consists of ammunition lethality characterization tests, followed by actual gun firings from an aircraft engaging targets expected to be attacked in combat.

## **TEST & EVALUATION ACTIVITY**

DOT&E has continuously participated in JSF OT&E and monitored LFT&E planning activities since June 1995. Integrated Product Team meetings have been held to coordinate the integrated program of DT&E, OT&E and LFT&E planned during SDD phase. The Combined Test Working Group (CTWG) is responsible for all T&E efforts in executing the JSF PDRR program and planning for the SDD program. The CTWG provides a single point of contact for the member services, OSD, and the weapon systems contractors for all T&E related matters. During the JSF PDRR Phase, competing contractor teams led by Boeing and Lockheed Martin each built, qualified, and flew Concept Demonstrator Aircraft designated the X-32 and X-35, respectively. Rather than being prototypes with full-up systems, these demonstrators incorporated the engine and outer mold lines of the contractor's JSF design and largely used off-the-shelf systems and avionics. These aircraft demonstrated the viability of each contractor's airframe design concept, including the ability to accomplish short take-offs, hover and transition to wingborne flight, up-and-away performance, and low-speed handling consistent with landing aboard a carrier. During this phase, each contractor was responsible for planning and executing the ground and flight tests and demonstrations.

The PDRR Phase allowed early test insights into the viability of basic aircraft designs of the competing contractors to meet the requirements of commonality/modularity for an affordable family of multi-Service aircraft. In addition, these aircraft demonstrated specific short take-off and vertical landing, hover, transition, and low-speed approach characteristics.

LFT&E activity in FY01 consisted of ballistic testing of two critical F119 engine components, the first-stage integrally bladed rotor (IBR), and the second-stage IBR. Seven shots were fired at rotating IBRs at the Naval Air Warfare/Weapons Division Weapons Survivability Laboratory, China Lake, CA.

## **TEST & EVALUATION ASSESSMENT**

At this stage of the JSF program, the integration of program planning and T&E planning appears to be on a solid foundation. However, in view of the complexity of the program objectives, numerous T&E opportunities and challenges are being, and will likely continue to be, encountered.

The JSF program adopted an iterative approach toward facilitating the Services' development of fully validated, affordable operational requirements. This approach emphasized the early and extensive use of cost-performance trades. In addition, the evolutionary acquisition strategy planned for JSF will result in three successively more capable blocks of aircraft, each of which will be tested against JORD requirements before production.

The JSF is expected to have significantly improved interoperability and C4ISR capabilities, as well as a very highly evolved set of sensors, all of which will be highly integrated with the avionics systems. These systems will provide the JSF with some of its most distinctive and important operational capabilities. Adequately testing these advanced capabilities at an operational mission level will be a challenge to the test program.

The JSF will employ some new technologies, and these must be identified early in the program so that they can be monitored during the test program. As one example, the method of providing vertical thrust to the STOVL variant will be a significant advance over the current operational systems and thus carries a corresponding risk, and extra attention should be given to this sub-system. Another area that should be given extra attention is the performance and maintenance requirements of the Low Observables (LOs) and other classified capabilities on the JSF, particularly in the shipboard environment. Current LO systems have experienced difficulty after being fielded, and the JSF test program should endeavor to identify these during early testing so that any required corrections can be completed prior to fielding the system.

Due to the expected high degree of commonality of the three variants, a single integrated test program is planned, which should save both time and money during the test program. During SDD, an integrated test team will perform all developmental testing and OTAs will conduct operational assessments and dedicated OT&E. The OTAs for JSF, AFOTEC and COMOPTEVFOR, with participation by the United Kingdom's Air Warfare Centre, are conducting an EOA that will support the Preliminary Design Review of the Lockheed Martin preferred weapon system concept in 2003.

During SDD, ground test and flight test aircraft will be built representing all three variants, and will be augmented by full-mission simulators and flying avionics testbed aircraft. The OTAs and DOT&E will continue as active participants in the Combined Test Working Group throughout SDD; and the OTAs as members of the JSF Integrated Test Force, will independently plan, conduct, and report a series of OAs. OTA activity will culminate with the conduct of dedicated OT&E in the FY10 timeframe in support of a full-rate production decision.

Although economy of testing is expected, the JSF is expected to perform many different missions, and the way each service carries out these missions sometimes have subtle but important differences that must be taken into account in OT&E planning. Adequately exploring this range of missions will be another challenge for the JSF test team.

Modeling and simulation is expected to play a large role in the operational evaluation of the JSF. For example, the JSF plans on supplying the Strike Warfare Collaborative Environment (SWCE) as Government Furnished Equipment, while the contractor will provide digital product descriptions (DPDs)

of the JSF that will operate within the SWCE. These efforts will provide new opportunities for integrating M&S with flight testing, but they will also raise new issues.

The planning and conduct of SDD include ample opportunities for the conduct of OAs leading up to dedicated OT&E. As the program matures, it will be essential to define specific accomplishments/ characteristics that each of the operational test periods can confirm consistent with the event-driven acquisition strategy required by DoD Regulation 5000.2-R and adopted by JSF. The current planning for dedicated OT&E includes 14 LRIP flight test aircraft in block two plus several ground test articles. While this quantity of aircraft is adequate for the conduct of a thorough operational test, it is not too many since three different aircraft configurations must be tested in the accomplishment of a variety of missions. In block three, six additional jets, two of each variant, will be added to allow for additional operational test requirements.

While survivability has two primary components, threat avoidance and damage tolerance, the JSF focused early on defining its susceptibility requirements (threat avoidance) in terms of radar and infrared signature levels. The program has identified engagement probabilities of kill given a hit (damage tolerance) to establish vulnerability and reparability requirements. The engine IBR ballistic tests indicated that the rotors could tolerate the damage inflicted by the threats tested. The overall effect of the damaged first-stage and second-stage IBR on overall engine performance is still being analyzed.

# **JOINT SURVEILLANCE TARGET ATTACK RADAR SYSTEM (JSTARS) E-8C, COMMON GROUND STATION (CGS), MULTI-PLATFORM RADAR TECHNOLOGY INSERTION PROGRAM (MP-RTIP), MULTI-PLATFORM COMMON DATA LINK (MP-CDL)**



The Joint Surveillance Target Attack Radar System (JSTARS) is a surveillance, battle management, and targeting radar system. It is a joint Air Force and Army program with the Air Force as the executive service. The system is required to perform surveillance and battle management for both air and land component forces. It is intended to meet the operational need for locating, classifying, and supporting precision engagement of time-sensitive moving and stationary targets. Three separate systems combine to perform the JSTARS mission, an Air Force E-8C aircraft, known as the JSTARS; an Army Common Ground Station (CGS); and the data link connection between the two. The system now includes the follow-on to the JSTARS sensor, the Multi-Platform Radar Technology Insertion Program (MP-RTIP) and the next generation data link, the Multi-Platform Common Data Link (MP-CDL).

The JSTARS airborne platform is a Boeing 707 designated the USAF E-8C. The basic airframe is 25 to 30 years old and has been extensively refurbished and updated with the JSTARS radar system, communications gear, 18 mission workstations, and air refueling capability.

The CGS receives, processes, and displays JSTARS radar imagery transmitted from the E-8C. The CGS is mounted on a High Mobility Multi-Purpose Wheeled Vehicle (HMMWV). It consists of computer workstations, communications equipment, and data link capability to integrate with the JSTARS aircraft, intelligence networks, and national level information sources. The CGS is expected to provide the Army ground elements with the capability to prosecute air and land engagement of time-sensitive targets and support the intelligence preparation of the battlefield.

The JSTARS program office planned four block upgrades and modifications for the E-8C. Block 10 provided the Tactical Digital Information Link (TADIL-J) Upgrade (TJU); Block 20 was the Computer Replacement Program (CRP); and Block 30 integrates satellite communications (SATCOM), the Attack Support Upgrade (ASU), and Improved Data Modem (IDM). The Multi-Platform Radar Technology Insertion Program (MP-RTIP) was restructured from the original Block 40 JSTARS radar upgrade. MP-RTIP is a program to develop modular, scalable, high-performance radars suitable for integration on a variety of air platforms, including Global Hawk. The current data link will be replaced by the Multi-Platform Common Data Link (MP-CDL), a program to develop a network-based application

of the standard DoD data link for the dissemination of intelligence, surveillance, and reconnaissance data.

## **BACKGROUND INFORMATION**

Although a Multi-Service Operational Test and Evaluation (MOT&E) was scheduled for FY96, the system was evaluated during the operational deployment, Operation JOINT ENDEAVOR (OJE) supporting the forces in Bosnia. While assessment in an operational context was valuable, it presented critical limitations to the scope of the evaluation. The system demonstrated only limited capability in support of target attack and battle management because of the nature of the air tasking. The E-8C did not meet its overall suitability requirements during the deployment and was evaluated as unsuitable to support a high operational tempo conflict. Because of these shortfalls and unresolved issues in MOT&E, OSD directed an E-8C FOT&E.

The CGS IOT&E was a series of three tests over two years, ending in March 2000. The tests revealed operational shortfalls in CGS effectiveness and suitability. Operators were unable to report on targets to intelligence or fire support nodes in a timely, accurate, and complete manner, and were unable to discern stationary targets from their background in the Synthetic Aperture Radar (SAR) mode. The benefit of including other sensor feeds in the CGS was not shown. The CGS was not suitable for tactical employment because it was incapable of on-the-move operations without power from the 10-kilowatt generator in its trailer, which was determined to be unsafe.

## **TEST & EVALUATION ACTIVITY**

Activity in FY01 focused on planning for the FOT&E of the CGS. The Army intends to rely heavily on modeling and simulation to address many unresolved operational issues. It has explored the use of the Tactical Aerospace Command and Control Simulation Facility (TACCSF) at Kirtland AFB as the venue for conducting much of the FOT&E. In 2001, the CGS participated in the TACCSF's quarterly Desert Pivot exercise to assess the feasibility of conducting the FOT&E during this exercise.

The MP-RTIP program produced a test strategy outlining the risk reduction to support Milestone B. The plan consists of limited developmental tests of low-level hardware components with performance of those components input into a sequence of models and simulations.

The MP-RTIP program is currently drafting a sensor test plan and a Wide Area Surveillance (WAS) platform TEMP. Additionally, the Global Hawk program office is incorporating MP-RTIP into its TEMP. Finally, AFOTEC has drafted an Early Operational Assessment (EOA) plan using the contractor's developmental test results and modeling and simulation to support the Milestone B decision. The MP-CDL program focused on defining its requirements.

## **TEST & EVALUATION ASSESSMENT**

In the JSTARS E-8 Test and Evaluation Report, DOT&E assessed the E-8C as operationally effective in operations other than war, but the system was evaluated as unsuitable to support a high operational tempo conflict. The radar picture provides information on large-scale movements of ground targets over a corps-sized area of interest. The commanders supported by JSTARS felt that it gave them a higher level of situational awareness than without JSTARS.

The CRP OT&E demonstrated that the computer upgrade did not degrade the performance of the E-8C or adversely affect its ability to perform its mission. The new radar processor of the Block 20 was far more reliable and the Block 20 E-8 had a higher effective time on station than the Block 10 aircraft.

The CGS was adequately tested to support the full-rate production decision. Testing and field operations show that the CGS provides a useful military capability and is effective for battle management and surveillance of large moving target sets (20 to 30 vehicles). The CGS cannot be considered operationally effective in the accomplishment of target attack missions and surveillance of company-sized target sets (8 to 11 vehicles). The CGS is not operationally suitable for its more stressing intended missions because of issues with reliability, training, and the inability to operate on the move.

The operational tests showed that the resolution of SAR imagery from the E-8C is inadequate for CGS operators to distinguish small tactical formations of vehicles from their background. This limits the ability of the CGS to support the surveillance and targeting of small tactical formations such as Scud missile units. Tests show that the CGS did not consistently and successfully target moving vehicles. Training of the operators, non-commissioned officers, crew, and staff is inadequate to fully exploit the capabilities of the CGS.

DOT&E is concerned with the availability of the JSTARS test bed aircraft, designated T-3, for planned JSTARS upgrades and the MP-RTIP test program. The USAF is planning to use T-3 as the test bed for MP-RTIP. This will impact availability of the T-3 for E-8C Block 30 upgrade testing. Unless another aircraft is assigned to the JSTARS program, flight testing of the planned upgrades to the E-8C will be forced to use an operational aircraft. Although they have been used for testing in the past, those tests have not required extensive aircraft modifications. To test current upgrades, substantial modifications will be required which may impact real-world operations. If these Low Density/High Demand aircraft are already committed to operational taskings, then the upgrades will be delayed. Thus, there may be a requirement for another a dedicated test aircraft.

## **LESSONS LEARNED**

There are two lessons to highlight from the JSTARS program. Lesson 1: Testing during wartime operations, in lieu of conducting dedicated OT&E, offers advantages and disadvantages that must be factored into the overall system evaluation. In OJE, JSTARS was required to interface with many agencies and systems. It was an opportunity to evaluate the system working with different users, operational and intelligence requirements, and military systems in situations not typically found in a formal OT&E. However, although JSTARS was integrated into an operationally realistic and complex environment, there were disadvantages of evaluating it during wartime operations. In OJE, evaluators were denied access to monitor some of the key military activities that JSTARS supported. This, combined with the inherent inability to put in test controls during the actual military operations, resulted in an OT&E that evaluated the JSTARS capabilities in that specific theater in that specific scenario only. Conditions and environments could not be varied and monitored, as they would have been possible

during formal OT&E, in order to answer specific questions about the system capabilities. Lesson 2: Coordination, system architecture, and procedures are often overlooked in the face of technical challenges. While there were significant technical challenges in the JSTARS program, for the most part, they were met. What plagued the operations of JSTARS equipped units was the lack of training (at both the operator and user level), inadequate Tactics, Techniques and Procedures (TPPs), interface difficulties, the lack of an architecture to integrate JSTARS with other systems, and the inability to fuse JSTARS information with other products into a useful intelligence product for commanders. This highlights that neglecting or underestimating these details can easily negate any technical advances that are made.



## **LARGE AIRCRAFT INFRARED COUNTERMEASURES (LAIRCM)**



The Large Aircraft Infrared Countermeasures (LAIRCM) System enhances individual aircraft survival through improved aircrew situational awareness of the electromagnetic threat environment. The fundamental requirement for the LAIRCM system is to provide protection against man-portable, shoulder-fired, and vehicle launched infrared (IR) guided missiles. The system will be installed on the C-17, the C-130, and the KC-135 aircraft. LAIRCM will autonomously detect and declare IR threat missiles, then track and jam the missiles to create a miss.

The system consists of five basic elements: a Control Indicator Unit (CIU), a Missile Warning Subsystem (MWS) which may consist of either or both ultraviolet and infrared sensors, a Pointer/Tracker Transmitter (P/T) subsystem, a Countermeasures Processor (CP), and a Laser jam source subsystem. The CP is the master system controller and the interface among subsystems. Up to three laser jammers will be installed on each aircraft type. All the subsystems, with the exception of the laser jammer, are non-developmental items (NDI) that have been previously tested as part of the special operations C-130 Directed IR Countermeasures Program (DIRCM).

### **BACKGROUND INFORMATION**

In response to the urgent requirement in the LAIRCM ORD, the Air Force Aeronautical Systems Center (ASC) developed an evolutionary strategy to yield a near-term solution for the protection of large transport type aircraft. The use of proven subsystem solutions, integrated into a LAIRCM system, is the first step in the LAIRCM Evolutionary Acquisition (EA) strategy to address the overall requirement. This first step, designated phase 1, is to identify a near-term LAIRCM solution. Four subsystems demonstrated the maturity and performance to provide a near-term solution. All or part of the selected subsystems will comprise the LAIRCM system. Four of the subsystems (CIU, P/T, CP, UV MWS) will come directly from the DIRCM Program, presently in production. The final subsystem will be a Multi-Band Laser Subsystem, which has undergone considerable laboratory and field testing.

The United Kingdom is the primary procurement authority for DIRCM; therefore, the system does not fall under the DoD 5000 procurement regulations. The United Kingdom has installed the system on nine different aircraft types and there are plans for integration on eight additional aircraft types. The DIRCM systems for the USAF special operations aircraft were bought under the UK contract. The special operations aircraft are currently undergoing a User Qualification Test on three different types of C-130s to ensure effective operation prior to deployment.

## **TEST & EVALUATION ACTIVITY**

Since the LAIRCM program was just started during FY01, the key test activity has been the review of past T&E that is relevant to the program and the preparation of the TEMP. There has been a significant amount of testing on the DIRCM system, and some testing on the multi-band laser, that will be used for LARICM. Also, the operational user evaluation (OUE) for DIRCM on three versions of the C-130 was accomplished in FY01. The reports from these tests will be key to justify the abbreviated operational assessment (OA) planned in FY02. The TEMP for this program was signed in the 4QFY01.

## **TEST & EVALUATION ASSESSMENT**

Since this program is using NDI items, it is relying heavily on tests that have been done in the past for the DIRCM system and the multi-band laser. This has resulted in an extremely compressed test schedule between Milestone B (4QFY01) and the Milestone C (3QFY02). Milestone C low rate initial production (LRIP) will be supported only by the review of past test results and an OA consisting of the jammer effectiveness tests. The multi-band laser will be tested as part of the LAIRCM system at the Air Force Electronic Warfare Evaluation Simulator (AFEWES) and at the Aerial Cable Car Facility (ACF) during the OA in the first and second quarter FY02 to support the LRIP decision. LAIRCM will undergo initial operational evaluation on the C-17 during FY04 to support the full rate production decision. No aircraft integration will be accomplished on the C-17 prior to Milestone C. OT&E on the integrated C-17 aircraft will be accomplished prior to the full rate production decision in FY04. Even though the DIRCM system has been integrated on several aircraft already, none have the new multi-band laser incorporated and every aircraft installation experiences unforeseen problems. Thus, the T&E plan has created a moderate risk for the program. Lesser risk is envisioned for the C-130 since the DIRCM system has already been integrated into this airframe several times.

## MILSTAR SATELLITE SYSTEM

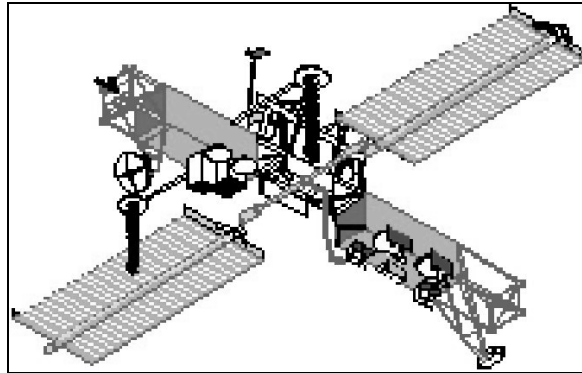

The Milstar satellite system supports strategic and tactical missions through global communications that are secure, jam resistant, survivable, and have a low probability of intercept. Milstar provides worldwide coverage for multi-Service ground, airborne, submarine, and shipborne terminal communications connectivity. There are the three Milstar segments—space, terminal, and mission control:

- **Space Segment:** The full Milstar operational capability will be provided by four geosynchronous satellites. The first two satellites possess the original strategic communications low data rate (LDR) payload, while subsequent satellites will also possess a tactical medium data rate (MDR) payload. Each LDR/MDR satellite uses a variety of antennas to support the requirements of both tactical and strategic users. Additionally, cross-links between the satellites provide worldwide connectivity without using vulnerable ground relays.
- **Terminal Segment:** The Milstar terminal segment consists of a family of multi-Service ground, shipborne, submarine, and airborne terminals functionally interoperable and tailored to meet the individual Service requirements. These terminals include the Air Force air and ground command post terminals, the Navy Extremely High Frequency Satellite Program (NESP) ship, shore, and submarine terminals, and the Army's Single-Channel Anti-jam Man-Portable (SCAMP) terminal and Secure, Mobile, Anti-jam, Reliable, Tactical Terminal (SMART-T).
- **Mission Control Segment:** The Milstar mission control segment provides communications resource management and satellite operations support. The primary responsibility of the mission control segment is to maintain the satellite in a state of readiness to support user communication requirements during all levels of conflict.

### **BACKGROUND INFORMATION**

The first Milstar satellite was launched in 1994 onboard a Titan IV rocket. The second satellite was launched in 1996. Milstar Flight 3, the first LDR/MDR satellite, was launched on April 30, 1999. However, the mission was declared a failure when a problem with the Centaur upper stage placed the satellite in a nonoperational orbit. Milstar Flight 4 was launched on February 27, 2001 and has undergone on-orbit acceptance testing. In lieu of an additional Milstar satellite to replace Flight 3, the

first flight of the Advanced EHF satellite program (Pathfinder) was to be launched on an accelerated schedule. Restructuring of the AEHF program to reduce technical and funding risk has eliminated the accelerated launch date, but the Pathfinder will be programmed to operate initially as a Milstar II LDR/MDR satellite.

Air Force Space Command declared IOC-1 for Milstar on July 21, 1997. The Milstar LDR system currently supports IOC-1 missions. MOT&E of the first LDR/MDR satellite will begin in FY02 and will support an IOC-2 decision in FY03.

### **TEST & EVALUATION ACTIVITY**

The LDR IOT&E was completed in March 1997. The Milstar IOT&E final Report (August 1998) stated that the Milstar LDR system was effective and suitable with limitations. DOT&E and Air Force Space Command (AFSPC) directed AFOTEC to retest six Measures Of Performance (MOPs). Of these, AFOTEC retested three connectivity MOPs during the period September 1999 to February 2000. AFOTEC also conducted tests from June 2000 to May 2001 to reevaluate two suitability MOPs.

The updated Milstar II (LDR/MDR) TEMP was approved by DOT&E in FY01. The MDR operational tests will focus on individual and combined Service terminals communicating through an in-orbit satellite. Operational testing with the Flight 4 satellite began with DT/OT events during the on-orbit test period and will continue with dedicated OT events that began in late FY01. Anti-jamming and low probability of intercept are two critical capabilities of the Milstar system, and both have undergone on-orbit testing in FY01. MDR uplink anti-jam capabilities were developmentally tested during the Milstar system test. MDR downlink anti-jam and low probability of intercept testing of the NESP MDR terminals was conducted for model validation purposes.

The Milstar system test results from Flight 4 show most of the space segment requirements have been met and the space segment is performing well. One of the primary new capabilities of Flight 4 and the subsequent satellites is anti-jam performance at medium data rates. This is accomplished by a nulling antenna, for which an on-orbit demonstration was planned. This DT/OT event was not conducted, but the operational test community will examine DT data collected during on-orbit testing. The operational test community including DOT&E will determine whether additional testing of nuller end-to-end system performance is required.

### **TEST & EVALUATION ASSESSMENT**

The Milstar Space Segment continues to perform well, as currently fielded with LDR capability. As there has been no operational testing with the on-orbit LDR/MDR satellite, no assessments can be made regarding operational effectiveness and suitability. However, review of the developmental test program for the space segment has not revealed any areas of operational concern.

The loss of Flight 3 (the first LDR/MDR satellite) degrades operational utility. Until the launch of Pathfinder in FY06, worldwide coverage from 65° South to 65° North latitude will not be available for the Milstar MDR terminals. The lack of a fourth medium data rate satellite will limit the ability to provide two-satellite coverage to some contingency operations and therefore limit the throughput of protected communications.

The Milstar Terminal Segment has met with mixed results. The Navy's LDR terminals have been successfully fielded for 4 years. The Air Force airborne terminal has recently demonstrated the required reliability and maintainability. However, the Army ground terminals have demonstrated reliability and maintainability shortfalls. Further discussion of the Navy NESP and Army SCAMP and SMART-T terminals are provided in separate sections of this annual report.

The Mission Control Segment for LDR operations has been performing its mission successfully since the launch of the first Milstar satellite in 1994. During LDR IOT&E, however, testing of a mobile constellation control station's ability to control the constellation revealed an endurance shortfall. DOT&E directed a full retest of the endurance requirement during follow-on testing. AFOTEC plans to conduct the endurance retest in FY02 and has identified their requirements to both USSPACECOM and USSTRATCOM, to determine the most appropriate joint exercise in which to participate.

Additionally, delays in development of the Automated Communications Management System (ACMS) are of concern. Because of the existing shortfalls of ACMS, the Army and other users plan to field their terminals initially with interim planning software (the Milstar Communications Planning Tool – integrated (MCPT-i)), as their primary planning tool. Under this scenario, MCPT-i should be tested to verify it meets all the requirements of the Mission Planning Element.

Finally, in the realm of interoperability, there is currently no concept of operations (CONOPS) for the Joint Task Force (JTF) mission. Test of the JTF mission is critical to evaluate interoperability of the Milstar system and terminals in an operational context. Some interoperability demonstrations have been conducted during developmental testing, and more will be conducted during Navy operational test events. However, until the CONOPS is specified, it is not known if the limited baseband used in these tests is operationally representative. AFOTEC has stated it will not test the JTF networks without a CONOPS; however, to support the IOC-2 decision in June 2003, AFOTEC needs to conduct the JTF operational test by Fall 2002. DOT&E recommends a CONOPS be developed as soon as possible.

This Page Is Intentionally Left Blank

# MINUTEMAN III GUIDANCE AND PROPULSION REPLACEMENT PROGRAMS



The Minuteman III ICBM consists of three solid propellant stages (including rocket motors, inter-stage hardware and ordnance), the liquid Propulsion System Rocket Engine, and the guidance set that can deliver up to three reentry vehicles. Five hundred Minuteman III ICBMs are currently deployed in hardened launch facilities at three operational bases.

The Guidance Replacement Program (GRP) is a set of hardware and software modifications designed to extend the service life of the Minuteman III while preserving its current capabilities. This program is needed to prevent a projected decline in reliability due to aging electronic components and unavailable replacement parts. GRP replaces the guidance computer, signal converters, and power distribution components while retaining the current Minuteman III inertial measurement unit. GRP is required to preserve current accuracy and reliability while enhancing supportability.

The Propulsion Replacement Program (PRP) will extend the life of the Minuteman III operational force by replacing the solid propellant propulsion subsystems. Due to observed failure modes (age-related degradations) and the rocket motors' approaching service life, the solid stages now in the force are projected to begin to deteriorate in 2002. PRP will remanufacture the solid rocket motors and inter-stage hardware and ordnance using new materials and processes that were qualified to replace unavailable or environmentally prohibited materials. In addition to hardware, PRP modifies two Minuteman III software elements, the Minuteman Operational Targeting Program and the Flight Program Constants Tape. These software modifications require use of the GRP-modified guidance system.

## **BACKGROUND INFORMATION**

DOT&E conducted an independent assessment of the GRP program from 1996 through 1999, culminating in submission of a report to Congress in December 1999 in fulfillment of the provisions of Title 10, U.S. Code, Section 2399. DOT&E determined that the GRP upgrades were operationally effective and suitable, although there had been insufficient numbers of flight tests (two) to confirm the accuracy and reliability assessments. The Air Force proceeded to full-rate production of the modified guidance systems in December 1999.

After two GRP flight tests and two PRP flight tests, the accuracy evaluation was still subject to considerable uncertainty. DOT&E required three additional flight tests to give the evaluation higher confidence in the demonstrated performance results. DOT&E agreed to accept data from already scheduled Minuteman III Force Development Evaluation (FDE) program flight tests as long as the missiles were configured with the GRP modified guidance system. After seven flight tests with the modified guidance system, the Air Force acknowledged a potential problem and conducted a supplemental accuracy investigation that identified several probable error contributors in the guidance system software. The Air Force is reviewing appropriate corrective actions and timing for implementation.

### **TEST & EVALUATION ACTIVITY**

Although the PRP IOT&E was completed in FY00, three additional flight tests conducted under the FDE program provided supplemental accuracy data for analysis in FY01. DOT&E completed its independent assessment of the PRP program, culminating in submission of a report to Congress in September 2001 in fulfillment of the provisions of Title 10, U.S. Code, Section 2399. The Air Force approved full-rate production in September 2001. All programmed operational test activities have been completed for GRP and PRP. Both programs are currently in full-rate production.

### **TEST & EVALUATION ASSESSMENT**

DOT&E found both GRP and PRP to be operationally effective and suitable even though accuracy performance, which is primarily attributed to the guidance system modified by GRP, did not meet the operational requirement. DOT&E determined that the shortfall in accuracy is offset by the overall improvement in weapon system reliability, which makes the Minuteman III weapon system more operationally effective than Minuteman III with the current guidance and propulsion systems.



## NATIONAL AIRSPACE SYSTEM (NAS)

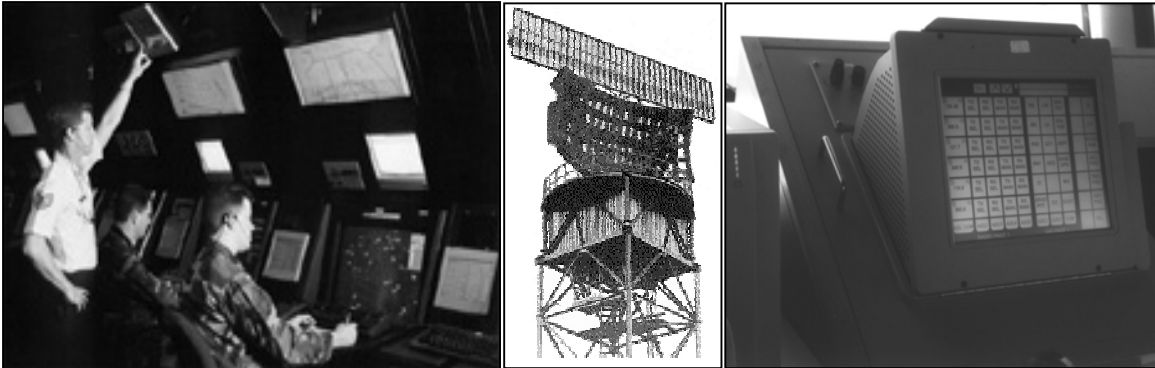

The National Airspace System (NAS) program will replace three types of Air Traffic Control and Landing System (ATCALs) equipment used to support the radar approach control mission. NAS includes voice switches, approach control and control tower automation, and airport surveillance radars. When fully fielded, the DoD NAS program upgrade will include the following four programs:

- Voice Communications Switching System (VCSS) is the communications component of the National Airspace System (NAS) modernization program. VCSS is being procured to replace existing analog voice systems approaching the end of their economic and technical life cycle. VCSS is designed to provide highly reliable, state-of-the-art air-to-ground, ground-to-ground, and intercom communications for controllers of military and civil air traffic.
- DoD Advanced Automation System (DAAS) receives and process primary and secondary radar data, flight plan information, weather, airport environmental data, and administrative information (such as Notices to Airmen).
- Digital Airport Surveillance Radar (DASR) consists of integrated primary and secondary radar subsystems to provide accurate target data to the local air traffic control facilities. The DASR should have improved target detection and accuracy, clutter rejection, aircraft identification accuracy, altitude data, and weather capability.
- Military Airspace Management System (MAMS) will schedule, track, and document utilization of special use airspace in a non-real-time manner, as well as interoperate with the FAA. Scheduling agencies will access the MAMS central web site using desktop computers with Internet access.

### **BACKGROUND INFORMATION**

The ATCALs equipment to be replaced has limited interoperability and excessive cost growth for operations and support. The Federal Aviation Administration (FAA) has undertaken a massive upgrade of the nation's air traffic control system infrastructure by replacing analog systems with state-of-the-art digital technology. Most DoD systems are currently analog and will not easily or economically interface with the new generation FAA equipment. Without the added capability, DoD will be unable to continue providing efficient and reliable service to all air traffic system users, military or civilian.

Furthermore, DoD NAS cost and operational effectiveness analyses indicate that DoD will experience excessive operations and support costs if the DoD air traffic control equipment is not replaced.

The FAA is the lead organization for VCSS and DAAS testing, with the Air Force serving as DoD lead for DASR testing and sole test agency for MAMS. DoD is working with the FAA through an interagency agreement for all VCSS, DAAS, and DASR test activities.

VCSS DoD MOT&E occurred throughout 1999. The VCSS was found operationally effective; however, it was rated not operationally suitable because of interrelated issues concerning parts reliability, maintainability, depot-level support, spares provisioning, and technical documentation. DOT&E reviewed corrective action taken after MOT&E and found them adequate to rectify the suitability shortcomings. The corrective actions, along with the high level of operational availability, inherent redundancy in the system, and demonstrated ability of the radar approach control and control tower to perform their operational missions, led DOT&E to conclude that VCSS was operationally suitable. The full-rate production decision was executed in November 1999.

MAMS was taken out of development to sustainment on October 1, 2000. Since then, three software versions have been released – one major release, and two minor releases. A third minor release is expected late 2001.

DAAS and DASR underwent combined DT/OT from October 1999 to January 2000 at Eglin AFB. Deficiencies were documented, some of which needed to be resolved before the start of the MOT&E, and others that needed to be resolved before full system fielding. Regression testing began in April 2000 at Eglin AFB and in June 2000, all deficiencies critical to the MOT&E were either verified as fixed or were downgraded in severity.

## **TEST & EVALUATION ACTIVITY**

DAAS and DASR began parallel MOT&E at Eglin AFB in June 2000 in support of the NAS Milestone III decision. As a result of DAAS and DASR deficiencies (15 Category 1 deficiencies; six DAAS and nine DASR) documented during the MOT&E, AFOTEC agreed to stop the MOT&E in October 2000 to allow the Air Force and Raytheon to make changes in the software that drives the digital radar and automation systems.

MOT&E resumed in March 2001 at Eglin AFB and continued through mid-April 2001. AFOTEC released its interim summary report June 2001. While the DAAS was found operationally effective and operationally suitable, the DASR was found not operationally effective and potentially operationally suitable. Nine Category 1 deficiencies were associated with the DASR. Major areas of concern included the lack of management of false targets, probability of detection, susceptibility of interference, and the performance of the weather channel.

Since the interim summary report was released, the program office has embarked on an aggressive plan for the path forward, modified its acquisition strategy, and re-baselined the program schedule. The program office has proposed that the MOT&E be conducted in February through April 2002 with the Milestone III decision in September 2002.

During the briefing to the Air Force in August 2001 on the NAS Acquisition Program Baseline breach, the Program Executive Office sought approval of a second LRIP buy for the DAAS and the DASR in March 2002 based on the DT results. DOT&E expressed concern with this approach since the

decision will be made without the benefit of OT and without the full complement of deficiencies being addressed.

### **TEST & EVALUATION ASSESSMENT**

DOT&E shares concerns with AFOTEC over the immaturity of the DASR configurations that have been presented for OT. After each test period, critical deficiencies were identified and the program office implemented plans to fix, regression test, and re-test operationally. During each test event, similar or additional deficiencies were documented.

DOT&E will work with AFOTEC, the program office, and users to establish credible re-entry criteria for the MOT&E. The program office must resolve all issues and operational impacts identified in AFOTEC's interim summary report. The test community must receive a coordinated position from the user community clarifying the false targets and probability of detection definitions in the Operational Requirements Document. The FAA must provide its detailed analysis on the DASR software that will undergo more MOT&E. Configuration audits must be complete and agreed upon by FAA and DoD users.

This Page Is Intentionally Left Blank

# NATIONAL POLAR-ORBITING OPERATIONAL ENVIRONMENTAL SATELLITE SYSTEM (NPOESS)

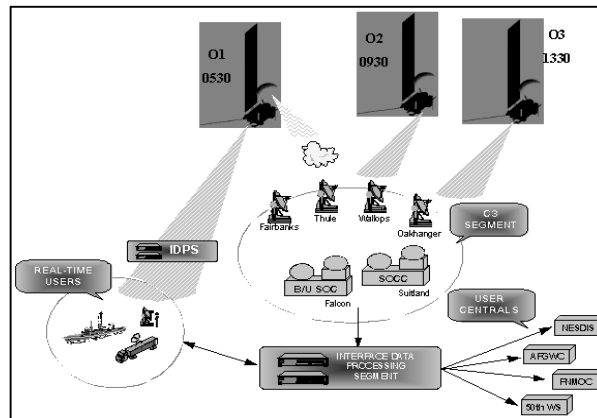

The National Polar-orbiting Operational Environmental Satellite System (NPOESS) is a Tri-Agency program jointly administered by DoD, the Department of Commerce's National Oceanic and Atmospheric Administration (NOAA), and the National Aeronautics and Space Administration (NASA). The program is managed by an NPOESS Executive Committee (EXCOM) through an Integrated Program Office (IPO) and is being acquired under U.S. Air Force acquisition authority. NPOESS will provide a national remote sensing capability to acquire and disseminate global and regional environmental data for a period of at least ten years after achieving initial operational capability.

NPOESS contains the following segments:

- A space segment, comprised of satellite payload components and ground support equipment, and operating in a sun-synchronous, near-polar orbit at a nominal 833 km altitude.
- A C<sup>3</sup> segment, providing for spacecraft control and state-of-health monitoring and supporting the delivery of data to designated centralized facilities and field terminals.
- An Interface Data Processor Segment (IDPS) comprised of data processing functions for centralized facilities and field terminals.
- A Field Terminals Segment (FTS) that receives direct real time mission data from the spacecraft into field terminals, and a NPOESS Preparatory Project (NPP) Science Data Segment (SDS) that is responsive to NASA's needs for science-quality data and algorithms.
- Launch Support, which is comprised of the resources to accomplish launch operations and to place the satellite in the correct orbit.

## **BACKGROUND INFORMATION**

NPOESS Milestone I occurred in FY97. The Program Definition/Risk Reduction (PDRR) phase was structured around system architecture studies, sensor and algorithm development, and Pre-Total System Performance Responsibility (TSPR) contracts. During PDRR, multiple contracts were awarded

for each higher risk sensor and/or suite of sensors and for system studies. Selection of the final TSPR contractor will occur shortly after Milestone B in FY02.

A key risk reduction activity is the NPP, which is a joint Integrated Program Office/NASA space flight of selected critical imager and sounding sensor systems. This flight, scheduled for FY05, will provide NPOESS with a risk reduction demonstration and NASA with selected sensor data to provide continuity with the current environmental and weather satellites.

## **TEST & EVALUATION ACTIVITY**

T&E and risk reduction activities in FY01 included revision of the Integrated Operational Requirements Document (IORD), an update of the TEMP, further definition of roles and responsibilities for a Combined Test Force (CTF) to conduct NPOESS testing, and development of a Memorandum of Agreement (MOA) between the IPO and the Services to refine Field Terminal concepts.

A revised IORD (IORD II) was approved by the Joint Agency Requirements Group (JARG). IORD II includes Interoperability as a KPP, defines top-level Information Exchange Requirements (IERs), and defines current field terminals and centralized facilities with which NPOESS is required to interoperate.

The initial TEMP was approved in 1997 and is currently being revised for Milestone B to reflect the current test strategy. The test strategy utilizes Modeling and Simulation (M&S) and combined DT/OT for early insight into the system's potential operational performance, followed by dedicated Multi-Service OT&E (MOT&E). During dedicated MOT&E, operational testers will conduct tests on production-representative hardware and software, supplemented as required with data from validated and accredited M&S. Two Operational Assessments (OAs) are planned: OA1 beginning in FY02 in support of Milestones B and, if needed, C, and OA2 in FY05 in support of Critical Design Review (CDR) and the NPP risk reduction effort. The MOT&E will be conducted once two satellites, the C3/IDPS, and a sufficient number of field terminals are fielded, nominally in the FY11 timeframe.

The concept of a tri-Agency Combined Test Force (CTF) was refined to correspond with the current acquisition strategy and to better define AFOTEC's role in each of the T&E activities within the overall NPOESS Operational Test (OT) concept. Although AFOTEC will be the lead agency for all OT&E events, it will combine efforts with other Service Operational Test Agencies, NOAA, and NASA during MOT&E to make the most efficient use of expertise and resources.

The IPO is developing a Memorandum of Agreement (MOA) with the Services on the issue of Field Terminal interoperability and funding. Under this MOA, the IPO proposes providing two direct data links to Field Terminal users, one for High Rate Data (HRD) in X-band at 20 Megabits per second (Mbps), and one for Low Rate Data (LRD) in L-band at 3.5 Mbps for more austere users. The IPO plans to demonstrate prototype NPOESS HRD and LRD terminals as a guide to users in modifying or replacing their existing terminals, and will fund and distribute non-proprietary HRD and LRD versions of Field Terminal IDPS. Under the proposed MOA, individual agencies are expected to fund, procure, and manage their own Field Terminals to satisfy their user needs.

## **TEST & EVALUATION ASSESSMENT**

No assessment of operational effectiveness or suitability can be made at this time. NPOESS is still in the Program Definition/Risk Reduction phase, only limited DT&E has been conducted, and no dedicated OT&E has been conducted on the program. DOT&E is focusing its current activities on reviewing risk reduction activities and test concept development. The following comments are based on DOT&E's early insight into program activities and are provided to foster the fielding of a system that meets all operational effectiveness and suitability requirements.

The test strategy for the era beginning with NPP, and beyond, is satisfactory. Final TEMP approval, however, is awaiting resolution of issues related to the degree of OT&E involvement prior to Milestone B, and the need for a Milestone C. The IPO plans to conduct source selection during much of the time remaining until Milestone B, which will severely restrict DOT&E's access to contractor data. DOT&E is negotiating with the IPO to develop an acceptable test strategy that balances the IPO's needs for an extended source selection with DOT&E's need for early involvement to support the Milestone B decision. Resolution of this issue may shift a portion of OA1 to a subsequent Milestone C.

The current field terminals used throughout DoD, the Department of Commerce, and the worldwide civilian community will not be capable of receiving NPOESS data in their current configurations. For example, the planned LRD frequency and data rate are substantially higher than the current DMSP Real-time Data Smooth (RDS) data or the POES Automatic Picture Transmission (APT). DOT&E is working with users to ensure that the IPO's proposals address all user requirements and that an integrated test strategy is developed to evaluate end-to-end interoperability.

For the space segment, the IPO is developing a Calibration/Validation (Cal/Val) plan for NPP and NPOESS sensors. The NOAA and NASA portions of the NPOESS community are conducting much of this work, and these Cal/Val plans and results are essential to the OT&E community for an adequate operational test program. The Atmospheric Infrared Sounder (AIRS) sensor on NASA's upcoming Aqua mission should be used to support validation of M&S of the NPOESS infrared sounder. Quality control of the data processing string in the IDPS should be planned to ensure that erroneous data is properly filtered and that operators are alerted whenever error conditions arise. In general, care must be taken to ensure that NPOESS provides for successful translation of science code to operational code for its users.

This Page Is Intentionally Left Blank



## NAVSTAR GLOBAL POSITIONING SYSTEM (GPS)

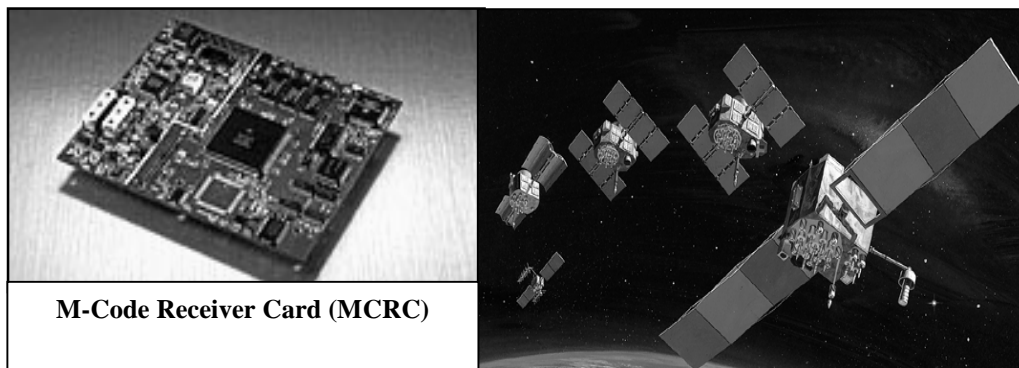

The NAVSTAR Global Positioning System (GPS) is an Air Force-managed Joint Service program that provides highly accurate, real-time, all weather, passive, common-reference grid position and time information to military and civilian users worldwide. It consists of three segments: space, control, and user equipment (UE). The space segment consists of a 24-satellite constellation in semi-synchronous orbits. The original Block I satellites were replaced with Block II/IIA satellites. Currently, Block II/IIA satellites are being replaced with Block IIR as the II/IIA satellites degrade on-orbit.

The control segment consists of a master control station, four ground antennas, a pre-launch capability station, and five geographically dispersed monitoring stations. The control segment monitors satellite downlink signals and uploads corrections to diminish errors broadcast to users. The user segment consists of numerous forms of GPS receivers that use satellite downlink signals to determine position, velocity, and precise time. These receivers are hosted on a multitude of platforms.

### **BACKGROUND INFORMATION**

An operational assessment of the first Block IIR satellite was conducted in July 1998. Although the IIR satellite met all navigation and timing requirements, a significant problem was found with the improved cross-link capabilities. The cross-link system sensed spurious radio frequency interference that inhibited completion of system tasks. An interim fix for the problem has been incorporated on the second and third IIR satellites, and a more robust resolution to the problem is being applied to the remaining Block IIR/IIR-M satellite family.

Currently, there are six Block IIR satellites on-orbit. The GPS IIR satellites provide the same functionality as earlier satellites, with added capabilities in two-way ranging and requiring less human interfacing for on-orbit operations. There are 16 additional Block IIR launches planned, with as many as 12 of these being the modernized or Block IIR-M version. The first Block IIR-M satellite launch is planned for late FY03. The IIR-M capabilities add developmental military use only M-code on the L1 and L2 signals and civil use C/A code on the L2 signal. Block IIF satellites are also under development, with the first IIF satellite launch planned for October 2005. The Block IIF satellites are functionally equivalent to the IIR/IIR-M satellites and add a completely operational M-code on L1 and L2, and a new separate signal for civilian use, designated L5.

Active user equipment programs include the production of Miniaturized Airborne GPS Receiver (MAGR) 2000 in FY00 and FY01, followed by platform installations in FY01 and beyond; Defense Advanced GPS Receiver (DAGR) deliveries beginning in FY03; and M-code receiver deliveries beginning in FY07. All receivers produced after FY02 are to have the Selective Availability Anti-Spoofing module (SAASM) capability installed.

## **TEST & EVALUATION ACTIVITY**

FY01 activity included continued test planning meetings, and the final staffing, coordination, and approval of the GPS Modernization TEMP in November 2001.

Future testing includes completing the Block IIR test, implementing the Block IIR-M (FY03) and IIF (FY06) test programs, and the evolution of the control segment. Full operational testing of the Block IIR portion of the GPS constellation will take place when seven to nine satellites are on orbit, and will assess IIR effectiveness and suitability against documented requirements (SORD). The assessment will also determine the efficacy of the cross-link problem fix. However, a series of operational assessments will be conducted in the interim, evaluating satellite functionality, control segment upgrades, and legacy and prototype user equipment.

The next round of IOT&E will occur when 24 operational Block IIR-M and Block IIF satellites are on-orbit and control segment software version 6 is declared operational. IOT&E will be a system-wide test of the space and control segments and legacy and future M-code capable user equipment. It is scheduled to take place in FY08-09.

## **TEST & EVALUATION ASSESSMENT**

Ground testing and preliminary on-orbit testing indicate that the proposed solution to the Block IIR cross-link problem is being resolved satisfactorily. The six successfully launched Block IIR satellites are performing their navigation and timing mission without any reported problem and are expected to meet all navigation and timing requirements for the IIR system. However, it is still too early to report a final determination of the effectiveness and suitability of the entire series of IIR satellites.

Delays in developing and testing the GPS Operational Control Segment are DOT&E's chief concerns. Control software segment development continues to be a moderate to high-risk area with an ambitious schedule. Development of M-code capable user equipment lags behind the development of the space and control segments, and this may induce delays in testing the Block IIR-M and IIF systems, along with the attendant M-code and civil signal capabilities.

The planned test approach provided in the new version of the GPS TEMP (approved November 2001) is straightforward and well thought out. Extensive joint developmental/operational testing is planned to ensure early and adequate insight into the new capabilities planned for inclusion into the GPS mission; i.e., associated control segment software and M-code functionality, second and third civil signals, and signal protection for U.S. and allied forces.

DOT&E continues to advocate the testing of new and legacy GPS receivers as early in the program as possible. These receivers must be integrated into representative platforms (i.e., ships, aircraft, and land vehicles) and tested in operational environments. DOT&E is monitoring very closely

the developmental and operational testing of the so-called ICD-compliant, Block IIA, IIR, IIR-M, and IIF compatible GPS cards that form the basis of the next generation of GPS user equipment. Full testing of these cards, and associated electronics, will not occur until M-code capable receivers are available (FY07 timeframe.) Before that time, backward compatibility and initial M-code performance of the new GPS cards must be tested in existing receivers, integrated into operational platforms.

DOT&E considers control segment software development as a moderate to high-risk area, with an ambitious schedule that will be difficult to meet. In the space segment arena, the M-code signal is not fully defined, and this uncertainty is beginning to impact development and test schedules. Resources should be brought to bear to ensure timely design and development of both control segment software and M-code signal generation on satellites.

Early operational evaluation/testing of integrated UE, including testing on an inverted range, must take place in the 2004-05 timeframe to ensure backward compatibility with existing UE and discover shortfalls that might exist in the design of M-code receivers.

This Page Is Intentionally Left Blank

## RADAR WARNING RECEIVER (RWR) AN/ALR-56M

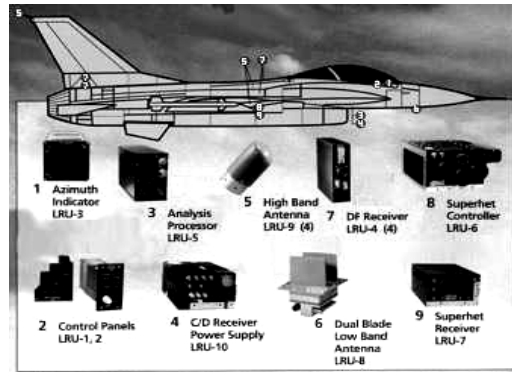

The ALR-56M Radar Warning Receiver (RWR) contributes to individual aircraft survival through improved aircrew situational awareness of the radar guided threat environment. It includes a fast scanning superhet receiver, superhet controller, analysis processor, low band receiver/power supply, and four quadrant receivers. It provides inputs to the ALE-47 CMDS (Countermeasure Dispenser System) to enable the selection and dispensing of chaff and flares for aircraft self-protection and provides ALE-47 status indications. The ALR-56M is designed to provide enhanced performance in a dense signal environment and improve detection of modern threat signals compared to the version of the ALR-69 that it replaces. A miniaturized version of the F-15's ALR-56C, the ALR-56M, is a form and fit replacement for the ALR-69 RWR in the F-16 Block 40 and other aircraft. The ALR-56M is the RWR chosen for integration into the open architecture Defensive System Upgrade Program in the B-1B bomber Conventional Mission Upgrade Program. The ALR-56M upgrades are developed in conjunction with upgrades to the ALE-47.

### **BACKGROUND INFORMATION**

The National Defense Authorization Act for the Fiscal Year 1989 directed that "all future operational results for RWR update programs be reviewed and approved by the Director of Operational Test And Evaluation, prior to obligation of production funds." ALR-56M is such a program.

A December 1992 DOT&E Beyond Low Rate Initial Production (BLRIP) report stated that ALR-56M was effective and suitable. In addition, the 1992 DOT&E BLRIP report recommended Follow On Test and Evaluation (FOT&E) "because of the deferral of tactics verification testing and the concern about bearing errors and delayed deletions during extensive maneuvers." The current TEMP calls for additional ALR-56M testing as part of continuing Block 40 and Block 50 F-16 follow-on testing.

FOT&E has been conducted by the U.S. Air Force Air Combat Command (ACC), Air Warfare Center on subsequent software versions. ACC has continued routine upgrades to Mission Data Table software to keep pace with the changing electronic order of battle priorities for various geographical areas of operation. However, tactics verification testing during FOT&E resulted in notations in the ALR-56M User's Handbook concerning the operational significance of the performance problems considered to be training issues. Training is required to ensure that aircrews understand ALR-56M performance during maneuvering.

Some of the major operationally significant changes associated with the latest software upgrade, Operational Flight Program (OFP) 0040, include the following:

- Reduced ambiguities between the Surface to Air Defense System (SADS) X TTR (target tracking radar) and AI (airborne interceptor) radars.
- Reduced number of multiple threat symbols associated with burst-ranging radars.
- Repeats of the missile launch audio warning instead of a one-time initial warning.
- Threat symbol age out as soon as a break-lock occurs during excess maneuvers, and re-display as soon as a new lock-on occurs.
- Improvements to the ALE-47 and the interface with it.
- System initialization, reset and internal communications deficiencies.

Requirements for changes to the fielded Operational Flight Program (OFP) include deficiencies noted in previous testing, desired enhancements targeted at handling evolving threats, and man-machine interface improvements directed at improving pilot situational awareness. Desired changes to the fielded OFP are a culmination of user requirements consolidated and prioritized by Headquarters, ACC, Air Force. A broad summary of those software changes include: (1) update of Mission Data threat parameters; (2) improved threat information interface with the ALE-47 expendable countermeasure dispensing system (OFP); and (3) improved detection of emitters with complex waveforms.

### **TEST & EVALUATION ACTIVITY**

Developmental Laboratory and Flight Testing of ALR-56M 0040 OFP, the latest software version upgrade, was conducted by the 416th Flight Test Squadron at Edwards AFB, CA, during 2QFY98-2QFY99 and encompassed a variety of Air-to-Air and Air-to-Ground flight profiles. The system transitioned to the 36th Electronic Warfare Squadron at Eglin AFB, FL, where it entered Phase I Operational Testing (Familiarization & Training) during 4QFY99. Several significant deficiencies were discovered in both DT and OT, and the program was halted for corrections 2QFY00. New, corrected software for DT was delivered in 4QFY00, followed by a combined DT/OT at Eglin during 3-4QFY01. The system was certified for entry into dedicated FOT&E at the end of 4QFY01, and DOT&E approved the FOT&E test plan at the same time. Ongoing OFP changes delayed finishing FOT&E in CY01, but tests are currently in progress.

### **TEST & EVALUATION ASSESSMENT**

Technical challenges, to fielding the new software update, center on resolution of problems with the new mission data generator, which require an extensive update for the new software version. Challenges do not appear insurmountable, but will require continued use of early system integration and robust testing to resolve and produce an effective and suitable upgrade. Interoperability testing with the EA-6B Prowler has yet to be accomplished. The FOT&E (Air Force uses the term, Force Development Evaluation) test delays should finish in FY02, with subsequent data analysis to follow.

## RQ-1A PREDATOR UNMANNED AERIAL VEHICLE (UAV) SYSTEM

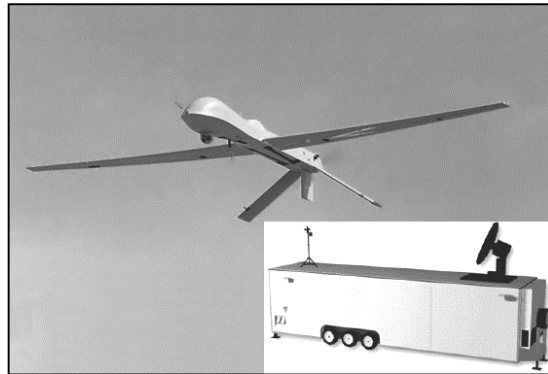

The Predator medium altitude endurance unmanned aerial vehicle (UAV) system is a theater asset intended to provide a cued and non-cued reconnaissance, surveillance, and targeting acquisition capability. The long dwell capability is intended to provide the theater commander with continuous imagery coverage of any area of interest. A capability is also being developed for the Predator to carry and fire the Hellfire laser-guided antitank missile, making it the first U.S. unmanned system to employ live weapons.

The Predator system comprises both air and ground segments. The air segment consists of four full composite air vehicles powered by turbo-charged Rotax 914 engines. The air vehicle can carry simultaneously Electro-Optic, Infrared (EO/IR) and Synthetic Aperture Radar (SAR) sensor payloads. Four EO/IR payloads and three SAR payloads will be provided for each system of four air vehicles.

The system will be required to operate in less than ideal weather conditions, and a glycol weeping-wing de-icing system was developed to provide the capability to transit through moderate icing conditions. Two sets of weeping wings will be provided for each system with four air vehicles. (The ability of the air vehicle to fly safely with the alternate weeping wings remains questionable, however.) The Predator will fly at altitudes up to 25,000 feet Mean Sea Level, and data link systems between the air vehicle and the ground system include C-band line-of-sight (LOS), and Ku-band satellite for operations beyond LOS.

The ground segment consists of a shelter containing the Ground Control Station (GCS) and a Predator Primary Satellite Link for satellite communications between the air vehicle and the ground station. Dissemination of imagery, both video and still image files, beyond the GCS is the responsibility of the supported commander. The typical crew in GCS comprises one air vehicle operator and one or two sensor operators per flight shift; an additional person may be present to input future targets and ad hoc target coordinates. For certain operations, such as relief-on-station procedures with two air vehicles under the control of one ground control station, an extra pilot is needed.

### **BACKGROUND INFORMATION**

Originally developed as an Advanced Concept Technology Demonstration (ACTD) program (1994–1996), Predator transitioned to an Acquisition Category (ACAT) II program in August 1997. The United States Atlantic Command (USACOM) was the operational user representative for the Predator

during the ACTD period and determined that the Predator had sufficient military utility to warrant production of more systems. The Joint Requirements Oversight Council (JROC) designated the USAF as the Service provider for the Predator. As such, the USAF developed an Operational Requirements Document (ORD), approved in July 1997, that delineated a number of system upgrades from the ACTD system with the top priorities being a de-icing capability, a UHF/VHF radio link for air traffic control through the air vehicle, improved IFF transponders, and repackaging of the GCS into a military style shelter. Other system capabilities upgraded from the ACTD to the baseline system are the more powerful turbo-charged Rotax 914 engine and reliability improvements. The USAF also developed a new concept of operations for the Predator that requires the air vehicle to maintain continuous coverage of the battlefield at ranges up to 400 nautical miles; a relief on station capability had to be developed in order to do this. The threshold requirement for this continuous coverage was stated as 75 percent effective time on station (ETOS).

USAF 11<sup>th</sup> and 15<sup>th</sup> Reconnaissance Squadrons at Indian Springs Air Force Auxiliary Field (ISAFAF), Nevada, currently operate Predator. Although the USAF has operationally deployed residual assets from the ACTD program nearly continuously since the ACTD ended, the first production-representative system with technical orders was delivered to the Air Force in April 2000. The Air Force has already procured its planned force structure of 12 Predator systems. Predator system number six was the first system retrofitted with all baseline capabilities and was used for initial operational testing.

According to the JROC-approved Tactical Control Station (TCS) ORD, the Predator air vehicle must be able to provide imagery directly to other Services' TCS-equipped ground stations, and TCS functionality in the Predator ground control station will consist of interoperability with defined Command, Control, Communications, Computers, and Intelligence (C4I) interfaces. When all Services have fielded UAVs and TCS-equipped ground stations, a joint interoperability test will be conducted. The U.S. Joint Forces Command (USJFCOM) is operating developmental TCS software with Navy-owned Predator air vehicles as part of their UAV Joint Operations Test Bed System to demonstrate this capability early on.

## **TEST & EVALUATION ACTIVITY**

AFOTEC conducted the initial operational test and evaluation (IOT&E) at ISAFAF during October 2000. The IOT&E comprised three phases. The first phase was the collection and scoring of reliability data on the production-representative system during training flights for several months prior to the flight operations phases of the IOT&E. The second phase consisted of two dedicated sorties designed to examine specific mission areas such as strike support, search and rescue, and mortar adjustment. The third and final phase of the IOT&E began with a simulated deployment to a designated area at ISAFAF. This 7-day, continuous operations phase focused on examining the ability of the system to maintain a continuous presence over the battlefield. Imagery was provided to a simulated exploitation cell where imagery analysts assessed image quality. The exploitation cell received video from the Predator GCS via the Nellis local area network. SAR imagery had to be manually transported from the GCS on floppy disks. The C4I architecture used for the tasking and dissemination during the IOT&E represented a deployed situation where there is access to local telephone landlines. It did not include satellite transmission of the EO/IR video from the GCS to other nodes including the Global Broadcast System (GBS). The test included one system comprising four air vehicles with EO/IR/SAR payloads, a ground control station, and 58 personnel (a planned deployed increment for a Predator squadron). Two sets of pre-production wet wings were provided.



The Joint Interoperability Test Command (JITC) assessed the Predator's C4I interoperability in three phases. The first phase assessed Predator imagery exploitation by the Distributed Common Ground System-Deployable Transit-cased System (DCGS-DTS) as disseminated by the GBS at Beale AFB, California. The DCGS-DTS and the GBS were actively supporting Predator operations in the European theater during this phase. The second phase was an assessment of the Predator interface to the video injection point into the GBS at the Bosnian Command and Control Augmentation Operations Center (BOC) located in the Pentagon. The final phase during the IOT&E was an assessment of the GCS link to the air traffic control and surveillance radars.

Air Combat Command conducted testing throughout the year to demonstrate the capability to employ the Hellfire air-to-surface antitank missile from the Predator UAV. The Air Force has maintained that this activity is experimental only. Neither test results nor information indicating an acquisition strategy to retrofit or purchase additional mission capability such as this in the Predator system has been made available to DOT&E.

### **TEST & EVALUATION ASSESSMENT**

Several limitations affected the continuous operations phase of the test. Continuous operations were interrupted by both weather and range restrictions. An unsafe flight profile discovered by the program office led the operations group commander to preclude any flights with the wet wings during the IOT&E. The lack of wet wing capability prevented transition through clouds, often keeping Predator close to home base. The lack of glycol-weeping wet wings (anti-icing) capability, combined with other weather and range constraints, prevented coverage of targets in the northern ranges for most of the test. Poor weather grounded the system on three separate occasions, and the loss of range time for 24 hours on another occasion reduced the flight hours to nearly half of the original plan. (Since the IOT&E, the Air Force has begun flight operations with the wet wings capability in training and operational deployments.) Feedback from users of imagery such as strike mission aircrew or planners was not solicited. Limited airspace and the necessity to deconflict with other flight operations on the Nellis ranges further restricted the air tasking order and provided little tactical uncertainty for the Predator operators who train over the same ranges routinely. However, the testing was adequate for the conclusions that follow.

The Predator UAV system is not operationally effective or suitable as tested during the IOT&E. This judgment rests primarily on an operational assessment against the user's standards for effectiveness and suitability as stated in the operational requirements document. The disparity between the apparently successful fielded system and a system that did not perform well in the IOT&E is largely attributable to the fact that the fielded system is tasked and operated well within known limitations such as ETOS, weather restrictions, expected threats, and expected accuracy and dissemination abilities. Additionally, the operators in the field have developed workarounds, somewhat effective but often cumbersome, for many system deficiencies.

AFOTEC found the Predator "to be effective, but not without limitations and difficulties" and "suitable though reliability and maintainability problems persist." While both AFOTEC and DOT&E agree on the limitations and difficulties encountered by the Predator system, the different conclusions about operational effectiveness are a result of DOT&E's perception that the system's limitations have a substantial negative impact on the Predator's ability to conduct its missions as described in the operational requirements document.

Although fielded operations prove that Predator has utility in certain mission environments, the IOT&E highlighted numerous shortcomings that limit its effectiveness. If uncontested by weather,

threats, or other factors that introduce tactical uncertainty, a deployed Predator unit is capable of surveillance, reconnaissance, and battle damage assessment missions. However, poor target location accuracy, ineffective on-aircraft radio communications, and limits imposed by relatively benign weather, including rain, negatively impact missions such as strike support, combat search and rescue, area search, and continuous coverage. The Predator sensor suite can provide only the desired performance during daylight or for slant ranges below the required 30,000 feet, and it cannot operate in less than ideal weather or sustain operations under conditions requiring chemical/biological protective posture. Furthermore, the system is unable to provide reliable, effective communications through the aircraft, as required, or meet the target location accuracy requirement under operational conditions (at slant ranges greater than 10,000 feet). The system demonstrated target location errors approximately twice what the accuracy requirement allows under operational conditions. The cumulative effect of the system's limitations renders Predator not operationally effective in meeting the mission requirements delineated by the Key Performance Parameters (KPPs) and the ORD.

Data extrapolated from the IOT&E suggest that the Predator could obtain *60 percent* ETOS at 400 nautical miles, *if relief-on-station procedures are used*. However, the procedures were exacting and confusing, immature, and developed solely for the IOT&E. The 57<sup>th</sup> Operations Group Commander restricted Predator from flying using relief-on-station shortly after the test concluded. The lack of relief-on-station procedures, combined with poor reliability, renders the system unable to meet the ETOS requirement of 75 percent (excluding weather downtime) at the ORD-required range of 400 nautical miles.

Additionally, the frequency of required preventive maintenance (every 19.4 hours on average during the IOT&E) is incongruous with the aircraft's expected sortie length (at least 20-hour sorties to maintain continuous coverage). Maintainability was affected by technical orders that were found inadequate by the maintainers. Additionally, a lack of in-depth system design makes the system not user friendly and difficult to learn, impacting training and mission effectiveness. Sixteen mission critical deficiency reports were cited at the end of IOT&E, many of which were related to human factors issues.

JITC has not yet certified the Predator system for interoperability in accordance with DoD Directive 4630.4 and DoD Instruction 4630.8 because of untested critical requirements. JITC certified only three of seven critical interfaces; the remaining interfaces have not been made available for JITC evaluation. The combination of poor reliability and maintainability, deficient human factors design, and lack of interoperability results in the finding that the Predator is not operationally suitable.

Predator's transition process from an ACTD to an acquisition program did not take full advantage of operational assessments (1995–2000) that identified key system shortfalls, many of which were repeated in the IOT&E. Development efforts did not correct many previously identified deficiencies. If the Predator system is to be effective and suitable in accordance with the ORD-structured mission capability, the shortfalls identified in the IOT&E must be addressed.

## RQ-4A GLOBAL HAWK UNMANNED AERIAL VEHICLE (UAV) SYSTEMS



The Global Hawk Unmanned Aerial Vehicle (UAV) system is a theater commander's asset designed to satisfy broad area coverage and deep target surveillance and reconnaissance shortfalls. The Global Hawk air vehicle is to provide high-resolution Synthetic Aperture Radar (SAR) and Electro-Optical/Infrared (EO/IR) imagery at long range with long loiter times over target areas. A Signals Intelligence (SIGINT) capability is also being developed. Potential missions for the Global Hawk cover the spectrum of intelligence collection capabilities to support joint combatant forces in worldwide peace, crisis, and wartime operations.

The Global Hawk UAV system comprises an air vehicle component with air vehicles, sensor payloads, avionics, and data links; a ground segment with a launch and recovery element (LRE); a mission control element (MCE) with embedded ground communications equipment; a support element; and trained personnel.

The Global Hawk air vehicle is optimized for long range and endurance; it is to be capable of providing 24 hours on-station at a 1,200-nautical-mile range from the launch site. It has a wingspan of 116 feet and length of 44 feet and has a cruise speed of 350 knots. The maximum operating altitude is 65,000 feet mean sea level (MSL), although it is capable of providing imagery after the air vehicle has climbed above 56,000 feet above ground level (AGL). The integrated sensor suite consists of SAR, EO, and IR sensors. Either the EO or the IR sensors can operate simultaneously with the radar. Each of the sensors provides wide area search imagery and a high-resolution spot mode. The radar also has a ground moving target indicator (GMTI) mode; GMTI data are transmitted as a text product providing moving target location and radial velocity (this information is not displayed graphically). Both SAR and EO/IR imagery are processed onboard the aircraft and transmitted to the MCE as individual frames. The MCE can mosaic EO/IR frames into images prior to further dissemination.

Navigation is via inertial navigation with integrated Global Positioning System (GPS) updates. Global Hawk is intended to operate autonomously using a satellite data link (either Ku or UHF) for sending sensor data from the aircraft to the MCE. The common data link can also be used for direct down link of imagery when the UAV is operating within line-of-sight of users with compatible ground stations.

The ground segment consists of the MCE for mission planning, command and control, and image processing and dissemination; the LRE for controlling launch and recovery; and associated ground

support equipment. (The LRE provides precision differential GPS corrections for navigational accuracy during takeoff and landings while precision coded GPS supplemented with an inertial navigation system is used during mission execution.) By having separable elements in the ground segment, the MCE and the LRE can operate in geographically separate locations, and the MCE can be deployed with the supported command's primary exploitation site. Both ground segments are contained in military shelters with external antennas for line of sight and satellite communications with the air vehicles.

## **BACKGROUND INFORMATION**

The Global Hawk program began as part of the High Altitude Endurance (HAE) Advanced Concept Technology Demonstration (ACTD) that included both the Global Hawk and the Dark Star UAV programs. The ACTD began in 1995 under Defense Advanced Research Projects Agency (DARPA) management, and in October 1998, transitioned to the Air Force systems program office at Wright Patterson AFB. The Dark Star program was canceled in January 1999. At the conclusion of the ACTD, United States Joint Forces Command declared the Global Hawk had military utility and submitted a military utility assessment in September 2000 to support the transition from an ACTD to an acquisition program. Early operational assessments (EOAs) produced by AFOTEC and DOT&E found the system potentially effective and potentially suitable. Residual assets from the ACTD include four air vehicles, two MCEs, three LREs, two SAR payloads, and one integrated sensor suite (with EO/IR and SAR).

The Air Force has developed an acquisition strategy that is based on a spiral development process leading to Global Hawk air vehicles that satisfy the needs identified in the Military Utility Assessment and validated in the Operational Requirements Document. Desired capabilities were divided between two spirals, which are to be met by the Block 5 and Block 10 configurations, respectively. The Milestone II decision in March 2001 approved entry into engineering and manufacturing development (EMD) for Block 5 and the spiral development of Block 10 Global Hawk, as well as low rate initial production of six Block 5 air vehicles, two MCEs, and two LREs. Prior to that decision, DOT&E approved the TEMP, asking for an update within 120 days of contract award.

The spiral nature of the development creates a dynamic environment in which testing will occur. Components of the system will be continuously upgraded and, in some instances, replaced during EMD. The situation is exacerbated by participation in demonstrations that require the development of unique capabilities to support those efforts. This occurred for the Australian deployment discussed below; additionally, a United States Southern Command demonstration scheduled for early 2002 requires the development of an air-to-air moving target indicator capability, and a German demonstration planned for late 2002 requires the integration of a European Aeronautic Defence and Space electronic intelligence (ELINT) sensor.

A decision by the Deputy Secretary of Defense in late 2001 directed acceleration of the Global Hawk program. This acceleration, and, potentially, the participation of Global Hawk in Operation Enduring Freedom, will require readdressing the user's operational requirements, acquisition strategy, and test strategy.

## **TEST & EVALUATION ACTIVITY**

Since the year-long demonstration and evaluation phase for the military utility assessment ended (June 2000), test activity has consisted of deferred testing objectives from the ACTD development,

testing of Block II modifications to the ACTD aircraft, an Australian deployment and demonstration, and preparatory developmental testing associated with that effort. Deferred testing objectives from the ACTD include characterizing the performance of the EO/IR sensor and the GMTI mode of the radar. Block II modifications include the replacement of the primary aircraft navigator, environmental control system modifications, fuel balance system modifications, and replacement of the spoiler actuators. The Australian deployment required the development of specific capabilities including a backup communications capability to support the deployment flight from Edwards AFB to Australia, maritime radar modes, integration of an ELINT sensor, and work to interface the MCE with the Australian Ground Element. Developmental testing was done in the United States to verify correct operation of these new capabilities before the deployment.

During the Australian deployment (April – June 2001), Global Hawk flew six sorties in support of Tandem Thrust, a joint U.S.-Australian exercise. Five additional sorties were flown to characterize system performance for the Australian Defence Forces in a more controlled environment.

### **TEST & EVALUATION ASSESSMENT**

In February 2001, DOT&E provided an EOA in support of the Milestone II decision. The EOA was based on the performance of the system during the June 1999 – June 2000 demonstration and evaluation period. The system was found potentially operationally effective and potentially operationally suitable. It was noted, however, that significant improvements were required in a number of areas.

Specifically, the system needed improvements in mission planning, imagery dissemination, scene accountability, system re-tasking, and communications bandwidth burden. The EOA noted significant unknowns in the area of effectiveness, including performance of the EO/IR sensor and GMTI mode of the radar. The EOA also noted the need for improvement in reliability in a stressing operational tempo as well as maturation of training plans, logistics infrastructure, and maintenance concept in order to provide an operationally suitable system. Development of a reliability growth management plan was recommended.

AFOTEC and the Australian Defence Science and Technology Organisation (DSTO) are developing a single summary report on the Australian Deployment to be released by the Australian Aerospace Defence Branch. A separate Operational Utility Evaluation (OUE) focusing on operational impacts and U.S. concerns was recently released by AFOTEC. DOT&E is reviewing these reports. Much of the raw data collected during the Australian Deployment are not yet available to DOT&E. Our assessment is preliminary and based on on-site observations by DOT&E representatives.

The primary focus of the Australian event was demonstrating Global Hawk's capabilities in the maritime/littoral surveillance role to satisfy Australian requirements. This was the reason for the development of the radar's maritime modes as well as incorporation of the Litton LR-100 ELINT sensor. There is currently no USAF requirement for either of these capabilities. The system was operated significantly differently from the envisioned USAF concept of operations. Also, because of the developmental nature of the system, significant contractor support was involved. Engineers and operators from Northrop Grumman, Raytheon, and L3COM were present in the MCE during all flights.

For the air vehicle, the Australian deployment represented the highest operational tempo attempted to date. The air vehicle flew fairly reliably; 13 of 14 planned sorties over 46 days were completed, totaling 287 flight hours. One sortie was aborted shortly after take-off when one of the new navigator systems reported a fault. The unit was found to be out of tolerance and was replaced.

However, because of concern regarding the navigator's fault reporting system, the following sortie was also canceled. A system engineer from the contractor's facility was flown to Australia to install a fix; this resulted in down time of about eight days. Another sortie was canceled due to a late engine start and high winds, but was completed the next day. The air vehicle also went into autonomous mode twice during the deployment when the MCE lost power. The air vehicle properly flew its autonomous profile while a backup generator was brought on-line.

The sensor system experienced numerous crashes and reboots during the deployment with each reboot requiring approximately 20 minutes. The crashes were likely influenced by the immaturity of the software with the recently added maritime modes as well as the unusual method of tasking where the Australian Ground Element was able to directly control the radar while the EO/IR scene collection was controlled from the MCE. Dissemination was also performed using non-standard methods including the Direct Dissemination Element and Australian dissemination channels.

Overall, the addition of experimental capabilities, presence of extensive contractor support and operation of the system, unique concept of operation employed, and use of non-system equipment in the deployment make it difficult to extract operational data relevant to the baseline configuration and USAF planned methods of employment.

## **SENSOR FUZED WEAPON (SFW)**



The CBU-97/B Sensor Fuzed Weapon (SFW) is a 1,000 pound class, unpowered, air-delivered, wide area cluster munition designed to provide multiple kills per pass against armored and support vehicles. The system has been certified on the A-10, B-1, B-2, B-52, F-15, and F-16 and is designed to be compatible with various USN/USMC and NATO aircraft. The weapon has the capability of being delivered in adverse weather conditions, day or night, at various altitudes and airspeeds. SFW consists of a SUU-66/B Tactical Munitions Dispenser (TMD), which houses ten BLU-108/B submunitions. Each submunition contains four projectiles, an orientation and stabilization system, a radar altimeter, and a rocket motor. After spin-up and release from the submunitions, the projectiles scan the area under their flight path with a two-color passive infrared sensor, while a signal processing logic classifies and filters out false targets. Upon detecting a valid target, an electronic pulse detonates an explosive charge, driving an explosively formed penetrator (EFP), an aero-dynamically stable slug, into the target. The SFW will be stored and transported as an all-up-round in the CNU-411A/E container. For typical tactical sorties, a combat load consists of four to six CBU-97/Bs. The SFW can be delivered at low or high altitudes (200 feet above ground level (AGL) to 40,000 feet mean sea level (MSL) (with Wind Corrected Munitions Dispenser (WCMD) tail kit)) and at low through supersonic speeds (250-650 knots). The SFW program is closely related to the WCMD and Joint Standoff Weapon (JSOW) Programs. Retrofit of SFW with WCMD tail kits began in April 2001. All SFWs will be retrofitted with the WCMD tail kit and will become CBU-105s. The SFW BLU-108 submunition will be a payload in the JSOW AGM-154B.

### **BACKGROUND INFORMATION**

The SFW program entered full-scale development in 1985, LRIP in March 1992, and full-rate production in June 1996.

The B-LRIP report submitted in May 1996 determined that SFW was only operationally effective when employed at low altitudes using level or shallow angle dive deliveries. SFW was designed for low altitude, direct attack delivery profiles. DESERT STORM experience resulted in an air doctrine favoring high altitude deliveries. The Wind Corrected Munitions Dispenser (WCMD) program was implemented to expand SFW employment options to reflect the change in air doctrine favoring high altitude releases. WCMD is an inertial guidance tail kit that replaces the existing tail section of current tactical munitions dispensers to improve delivery accuracy when released from medium to high altitude. The SFW with the WCMD is designated as a CBU-105.

In 1996, the Air Force instituted a Preplanned Product Improvement (P3I) program which implements three major improvements: (1) performance against countermeasures; (2) performance against softer targets without degrading the current target-set performance; and (3) increased area coverage. The current sensor will be upgraded from passive-only to a dual-mode active passive type to enhance the sensor's performance against cooler targets and improve weapon aimpoint. The Sensor Fuzed Weapon P3I submunition is designated a BLU-108B/B and the "all-up-round" is designated the CBU-97B/B, and CBU-105B/B with the WCMD tail kit.

Producibility Enhancement Program (PEP) hardware upgrades were initiated for SFW to reduce costs and improve producibility through design improvement. PEP-1 involved electronic and mechanical changes to the projectile. FOT&E 1 of PEP-1 was completed in 1998 and testing results indicated that PEP-1 changes did not degrade the performance of the Sensor Fuzed Weapon. The Sensor Fuzed Weapon TEMP was updated and approved in August 2000 to reflect the changes in the test program.

The LFT&E strategy for SFW P3I included: (1) collection of sensor data against a representative target set to determine impact points; (2) warhead performance data against armor plate targets; (3) three test shots that repeated shotlines from the original SFW testing in 1990; and (4) two additional tower shots. The SFW TEMP specifies that LFT&E for the SFW P3I must be completed before the FRP-7 contract award, scheduled for March 2002.

SAF/AQ approved production of the SFW P3I In January 2001. WCMD Milestone III was approved in February 2001. No further acquisition milestones are planned for SFW.

## **TEST & EVALUATION ACTIVITY**

Sensor Fuzed Weapon P3I DT/OT flight test weapon deliveries were completed in May 2001 using operationally representative delivery profiles, including WCMD. The final DT/OT mission, a high altitude cold soak mission, was considered a No Test due to a failure not related to the SFW P3I. Since DT/OT depleted the inventory of P3I hardware manufactured to date, this mission will be repeated when additional P3I assets are available for FOT&E III, end-to-end testing of the P3I configuration planned to begin FY02 using the first production weapons.

SFW P3I warhead characterization testing was completed in late 2000. Warheads were fired against rolled homogeneous armor plates of various thicknesses, including semi-infinite plates. Data were gathered on the flight characteristics of the central penetrator and multiple explosively formed penetrators (MEFPs). Terminal ballistic data included penetration depth, crater volume, hole diameter and behind armor debris characterization. Also recorded were dispersion and shape of the EFP and pattern of the MEFPs. Since P3I data was comparable to performance data for the SFW baseline warhead, Phase I tower testing against realistic targets proceeded.

Phase I tower testing was conducted with SFW P3I warheads fired from a tower. The azimuth, elevation, and slant range to the target were representative of likely tactical engagement scenarios. Three Phase I test events were conducted. Shotlines were designed to duplicate, as much as possible, shotlines from SFW baseline testing in order to facilitate direct comparison of results with those from the baseline tests. The Phase I shots were completed in December 2000. Phase II shots were conducted in August/September 2001.



## **TEST & EVALUATION ASSESSMENT**

Delays in the P3I submunition development affected the planned cut-in date for P3I into the Sensor Fuzed Weapon and will result in the procurement of fewer P3I versions of these weapons than originally planned. The P3I cut-in acquisition decision was based on preliminary results through nearly 90 percent of combined DT/OT. The final DT/OT mission and analysis of the data were not complete and the results of Phase I tower shots, although not Acquisition Decision Memorandum criteria, were not complete. Subsequent analysis of DT/OT showed notable effectiveness improvements over baseline weapons. A complete analysis of end-to-end operational effectiveness and suitability will be conducted following FOT&E III.

Previous operational testing of the Wind Corrected Munitions Dispenser demonstrated additional Sensor Fuzed Weapon employment capability from medium and high altitudes. SFW P3I confirmed these results, including interoperability with the B-52H with corrections for weapon built-in-test failures and a lack of display of weapon status previously reported, with the exception of a high altitude cold soak mission. Air Combat Command and AFOTEC recommended end-to-end test weapon releases with corrections, including the high altitude cold soak mission, before release to operational B-52 units. FOT&E III results will be used to determine effectiveness and suitability of the P3I weapons.

Warhead characterization testing had two primary objectives. First, provide fundamental warhead performance data to characterize warhead performance and provide for direct comparison with the baseline warhead. Second, provide sufficient empirical performance data to support updating the Point Burst Damage Assessment Model (PDAM) for use in future performance evaluation and scoring operational weapons test events. A review of the preliminary test data revealed the objectives were successfully achieved in characterization testing, and the program proceeded to Phase I tower tests. Final test reporting of the characterization test data has not been completed and will be included in the LFT&E report.

Phase I tower testing was conducted in accordance with the approved detailed test plan. Inherent angular errors in aiming the static warhead, combined with the substantially increased slant range (compared to the baseline test configuration), resulted in larger than anticipated errors between aim and impact point in the Phase I tests. Despite these errors, the major objectives of the Phase I tests were accomplished. Review of the preliminary damage assessments indicated that further tests against the Phase I targets were unlikely to contribute to assessment of: (1) lethality of the warhead against wheeled light armored targets, (2) performance of the MEFPs against light armored targets, and (3) reaction of stowed munitions and energetic materials to behind armor debris and MEFP impacts. This and warfighter requests to investigate performance against certain other targets led to the selection of an alternative target vehicle for Phase II.

Phase II tests were conducted to expand the data for LFT&E and support the warfighter requests. The major objectives of the Phase II tests were accomplished and contributed significantly to a broader understanding of SFW P3I lethality against the spectrum of expected targets. No consolidated report of characterization testing, Phase I, or Phase II test results have been provided yet and analysis is ongoing. A separate LFT&E report will be submitted once analysis is complete.

This Page Is Intentionally Left Blank

## SPACE-BASED INFRARED SYSTEM (SBIRS)

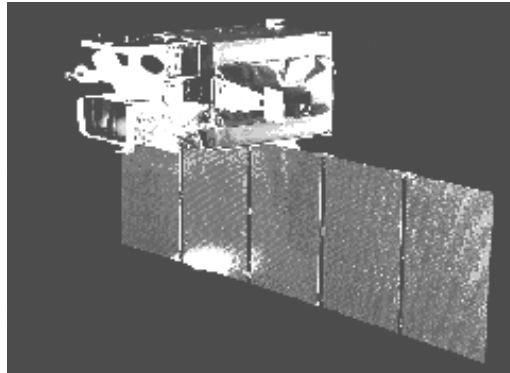

The Spaced-Based Infrared System (SBIRS) replaces the current Defense Support Program (DSP). Utilizing infrared sensor technology, orbiting SBIRS satellites will detect, track and report missile launches. SBIRS improves support to theater CINCs, U.S. deployed forces, and allies by providing better data quality and timeliness in four mission areas: Missile Warning, Missile Defense, Technical Intelligence and Battlespace Characterization.

The SBIRS is being acquired in three increments. Increment 1, which was declared IOC in FY02, consolidates DSP and Attack and Launch Early Reporting to Theater (ALERT) ground stations into a single CONUS ground station. Increment 1 operates with DSP satellite data. Increment 2 upgrades Increment 1 software and hardware to operate SBIRS High satellites. SBIRS High includes four satellites in Geosynchronous (GEO) orbit, with first launch in FY04, and two hosted payloads in Highly Elliptical Orbit (HEO), first available in FY02. A fifth GEO satellite will be procured as a replenishment/spare. SBIRS High satellites will primarily improve on current DSP operational performance. Increment 3 will operate SBIRS Low satellites, which will provide a mid-course tracking and discrimination capability for effective ballistic missile defense. SBIRS Low includes approximately 24 Low Earth Orbit (LEO) satellites, and several spares, with first launch in FY06. SBIRS Low ground mission software was to follow an evolutionary deployment, beginning with a release in FY06 to operate the first satellites, and slated to reach full mission capability in FY09. Recent budget revisions, however, have caused a redefinition of the SBIRS Low program, with emphasis on further sensor research efforts. Program redefinition is ongoing.

### **BACKGROUND INFORMATION**

The SBIRS Increments 1 and 2 entered the EMD phase following a Milestone II DAB review in October 1996. Increment 3 entered the Program Definition and Risk Reduction (PDRR) phase with Milestone I approval in August 1999, and two competing PDRR contracts were awarded. During FY99 the Air Force made substantive programmatic changes to SBIRS Increments 2 and 3 based on a restructured FY00 budget. For Increment 2, the Air Force delayed launch of the first GEO satellites from FY02 to FY04, and rescheduled incremental deliveries of the ground segment to align them with the delayed satellite schedule. For Increment 3 Low satellites, the Air Force delayed first launch from FY04 to FY06, and canceled two proof-of-concept demonstration satellites. To mitigate the increased risk due to cancellation of the flight demonstrations, DOT&E recommended that the Air Force develop an

acquisition strategy with significant design flexibility in the first six satellites, and at least a one-year launch hiatus following those first six.

In February 2000, Increment 1 breached its IOC baseline because of problems and delays with software development. Increment 1 was re-baselined with a November 2001 estimated operational certification date, which was met following IOT&E.

In November 2001, the Program Office notified OSD of serious schedule and cost issues with Increment 2 that may require additional funding and/or further delays. These issues are currently being reviewed by the Air Force and OSD acquisition executives. SBIRS Low was transferred from the Air Force to BMDO at the end of FY01. The Air Force is working with BMDO to review the program's DAB acquisition status and schedule.

### **TEST & EVALUATION ACTIVITY**

Increment 1 entered IOT&E in June 2001, with several known deficiencies and limitations to be corrected post-IOC. These included problems meeting tracking and reporting requirements (e.g., false report rate, raid count, launch azimuth, missile typing) on certain missile events, inadequate memory and processor reserves, and the need to upgrade the nuclear survivability of certain ground assets. During IOT&E, additional deficiencies were identified involving software problems and operational dependability. One of the software problems identified during OT&E was caused by false tracks initiated on a non-target, which filled memory and processing capacity and led mission-processing servers to crash. This problem was deemed sufficiently serious to pause the IOT&E while a software fix was installed. Pausing the IOT&E caused a change in the configuration baseline, and required regression testing and a restart in collecting suitability data.

SBIRS High satellite T&E activity during FY01 included continued HEO DT&E, Critical Design Reviews (CDR) on the GEO Payload and on the Increment 2 integrated ground-space system, and completion of the Advanced Sensor Test and Integration Facility (ASTIF) at Aerojet to support sensor payload qualification and acceptance testing. The GEO CDR approved development of a revised GEO "solar flyer" configuration, as opposed to the original "plane flyer." The solar flyer configuration corrects a potential problem with off-axis solar rejection, which would have caused problems in meeting Key Performance Parameters (KPP). The solar flyer configuration will require installation of an extended solar shade on the spacecraft, and in-plane yaw and flip maneuvers to maintain the solar shade between the telescope and the sun. GEO qualification tests will begin in 4QFY02.

SBIRS Increment 3 T&E activity during FY01 included continued development of contractor models, simulations, and facilities to conduct PDRR-level ground demonstrations of Critical System Performance Characteristics in preparation for MSII and entry into the EMD phase in FY02.

### **TEST & EVALUATION ASSESSMENT**

Based on results its IOT&E, Increment 1 is effective and potentially suitable. Operational effectiveness however, was affected by degradations of missile warning accuracy, timeliness, and reliability caused by the limitations and deficiencies described above, as well as mission software problems found during IOT&E. The most serious problems have already been corrected, workarounds are in place for other problems, and users can accomplish the basic missile warning mission using Increment 1. Post IOC-1 software upgrades to address the workarounds are planned in January 2002.

Increment 1 is only potentially operationally suitable because of dependability problems caused by immature software, the lack of a backup to the DSP-legacy Satellite Readout Station (SRS), and non-SBIRS limitations in Milstar's dependability. The SRS dependability shortfall is due to the lack of a backup satellite antenna with control capability to support training or satellite control while one of the two primary antennas normally used to control and monitor operational spacecraft is down for preventive maintenance. Survivability problems are primarily caused by the need for Hardness Maintenance / Hardness Surveillance (HM/HS) upgrades at the Survivable Relay Ground Station (SRGS) and the Survivable Mission Control Station (SMCS). Some of the software problems identified during IOT&E were a repetition of problems initially identified during DT&E, suggesting an inadequate deficiency correction process.

Increment 2 will not enter IOT&E until FY07, and DOT&E's current role is maintaining insight into developmental activity to ensure that the system is progressing towards an operationally effective and suitable system. We remain concerned with the schedule risk from the degree of concurrency between the Increment 2 ground and space segments, and with the adequacy of Models and Simulations (M&S) for IOT&E support. Concerning schedule risk, the Increment 2 ground segment will be fielded in late FY05, coincident with operational turnover of the first GEO satellite, and there is no fallback for late delivery of Increment 2 software. In comparison, Increment 1 development was late by nearly 2 years, but the legacy DSP ground system continued to perform the operational mission. Any delays in Increment 2 ground segment development may incur the risk of having to operate an on-orbit asset without a certified operational ground segment. Concerning M&S, adequate simulation tools to develop operational scenarios for Increment 2 training and IOT&E have yet to be developed. Furthermore, the spacecraft yaw and flip motions required by the new solar flyer configuration for the GEO satellites may introduce dynamics in the imaged earth background which complicate clutter rejection algorithms and may require re-accomplishment of any M&S validation activity based on the previous plane flyer configuration. The Program Office has agreed to the establishment of an inter-agency Sensor Analysis Team to independently assess this and other sensor-related issues.

For Increment 3, while the current acquisition strategy provides for an almost two-year on-orbit evaluation period for the first group of satellites, the production schedule for the remaining satellites remains so aggressive that it is doubtful improvements could be made to subsequent satellites based on observations gained from the first six, without a break in production. However, we recognize that SBIRS Low is constrained to this procurement strategy by its launch schedule and the required NMD need date. Early on-orbit testing of SBIRS Low satellites must utilize realistic test targets and must incorporate design flexibility as a mitigation for the risk of on-orbit failure. It is critical that M&S-based scenarios and test targets be intelligence-validated. NMD targets must conform to threat-representative configuration and deployment, to include realistic countermeasures. Given the three- to four-year development time required for new targets, it is essential that target development begin as soon as possible.

This Page Is Intentionally Left Blank

## **TRANSCOM REGULATING AND COMMAND & CONTROL EVACUATION SYSTEM (TRAC<sup>2</sup>ES)**



The TRANSCOM Regulating and Command & Control Evaluation System (TRAC<sup>2</sup>ES) was developed to combine transportation, logistics, and clinical decision elements into a seamless patient movement automated information system (AIS). The system assembles, assesses, and prioritizes patient movement requirements, assigns proper resources, and distributes relevant data to deliver patients efficiently. It automates the two processes of aeromedical evacuation and medical regulation (assignment of patients to suitable military treatment facilities), replacing two legacy AISs. TRAC<sup>2</sup>ES is now being used at the Global Patient Movement Requirements Center (GPMRC) at Headquarters, TRANSCOM; at the two Theater PMRCs (TPMRCs) located at Headquarters, United States European Command and Headquarters, United States Pacific Command; and is being fielded to aeromedical evacuation activities at military treatment facilities (MTFs) and intermediate staging facilities worldwide. TRAC<sup>2</sup>ES also includes a deployable capability for use during contingencies. TRAC<sup>2</sup>ES fuses information, logistics, and transportation technologies to provide rapid medical regulation and patient evacuation during crisis situations. It enables a deployed force to be more efficient in protecting lives.

### **BACKGROUND INFORMATION**

TRAC<sup>2</sup>ES was originally planned to be a module of the Global Transportation Network, but in late 1996, TRANSCOM decided to develop it as a separate system. Technical program responsibility was assigned to the Air Force and AFOTEC was designated the independent OTA. In July 1998, TRAC<sup>2</sup>ES was granted Milestone I/II approval, and a development contract was awarded to Booz, Allen & Hamilton of McLean, VA. Subsequent cuts in funding delayed the program and effectively curtailed development of any further increments once the Initial Operational Capability (IOC) version was fielded.

### **TEST & EVALUATION ACTIVITY**

With DOT&E endorsement, AFOTEC used a Combined Test Force (CTF) approach to integrate OT&E into the early stages of the acquisition process. This permitted early deficiency identification and resolution, and facilitated incremental refinement prior to IOC. Working with user representatives, the OTA developed mission level requirements that could be tested comprehensively during IOT&E. In October 2000, a type of operational assessment called Operational Field Test (OFT) was conducted in an artificial operational environment. Because it was still part of DT&E, the OFT was conducted under the

lead of the contractor, but AFOTEC designed the scenarios and closely monitored the testing. During the last stage of DT&E, the contractor made a number of final “fixes.”

AFOTEC conducted independent OT from March 26 through May 4, 2001, focusing on two major evaluation areas: (1) rapid evacuation of patients from a theater and (2) efficiency of global patient movement operations. AFOTEC addressed the first area during a 1-week command post exercise held in the United States. The OTA addressed the second area over a 6-week period by direct observation of TRAC<sup>2</sup>ES support of daily patient movement at the GPMRC at Scott AFB, IL; at the TPMRC at Ramstein AFB, Germany; and at several MTFs throughout the United States and Europe.

### **TEST & EVALUATION ASSESSMENT**

DOT&E considered TRAC<sup>2</sup>ES operationally effective and suitable (with one exception), based on a combination of: (1) demonstrated system performance against user requirements, and (2) operator judgment of mission accomplishment. DOT&E considered only one area (user training and manuals for deployable operations) to be unsuitable. Setup of the deployable TRAC<sup>2</sup>ES equipment and communications is very complex. Currently, no one is trained to do this, and there are no technical manuals or instructions.

TRAC<sup>2</sup>ES is a major improvement over the increasingly unsupportable legacy systems and greatly enhances the in transit visibility (ITV) of patients during medical evacuation. The system ushers in a new way of doing business wherein various users will now have to keep computer data bases updated, but the ITV information will be better and much more readily available than before. The deficiency regarding setup of the deployable capability, while significant, does not inhibit the deployment of TRAC<sup>2</sup>ES to the fixed locations of the GPMRC and the two TPMRCs. The PM declared IOC in July 2001 and full fielding is in progress. A major lesson learned is that the CTF process can facilitate the development of a quality product, even in the face of very limited funding.



## WIDEBAND GAPFILLER SATELLITE (WGS)

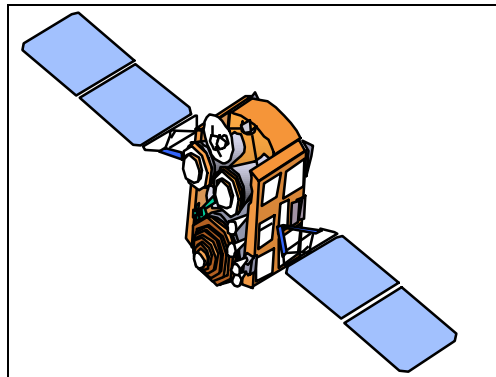

The Wideband Gapfiller Satellite (WGS) communications system will provide communications to the US warfighters, Allies, and Coalition Partners during all levels of conflict short of nuclear war. It is the next generation wideband component in DoD's future Military Satellite Communications (MILSATCOM) architecture.

WGS will satisfy military communications needs by providing communications in both the X-band and military Ka-band frequencies. It will combine capabilities onto a single satellite for tactical X-band communications, augment the Global Broadcast Service (GBS) Phase II system, and provide new two-way Ka-band services. This new service is being introduced to alleviate the spectrum saturation of X-band, and should greatly increase both the available single-user data rate and total satellite capacity over today's DSCS III satellites.

### **BACKGROUND INFORMATION**

The satellite segment is being acquired by the Air Force under the FAR Part 12 rules for commercial item acquisition. Because of its commercial nature, this program has no lead-in development phase, but will proceed directly from award to launch in one combined EMD/Production phase. The development schedule is three years, with first launch in 1QFY04. The final two launches are planned for 1Q and 3QFY05. The ground control segment is being acquired by the Army. The WGS space and ground segments and the GBS program are all being integrated by the MILSATCOM Joint Program Office (MJPO).

The 2001 Defense Appropriations Act signed on August 9, 2000, limited funding to two satellites. Subsequently, the Office of the Secretary of Defense (OSD) signed a Program Decision Memorandum (PDM) on August 22, 2000 supplementing WGS funding by \$272.9 million to ensure funding of the complete constellation of three satellites.

### **TEST & EVALUATION ACTIVITY**

Test and evaluation planning continued in FY01 for the WGS system. A Milestone II/III TEMP was approved by DOT&E on October 26, 2000. AFOTEC completed an early operational assessment

(EOA) of the Wideband Gapfiller Satellite (WGS) system September 2000 in support of a combined milestone II/III decision.

### **TEST & EVALUATION ASSESSMENT**

DOT&E received the WGS EOA outbrief on November 7, 2001, with the following issues highlighted:

- The complexity of cross-banding between the X-band and Ka-band on board the satellite and the concurrent development of the Gapfiller Satellite Configuration Control Element (GSCCE) with the automation upgrades of the Satellite Operations Center (SOC) and Defense Satellite Communications System (DSCS) Operations Center (DSCSOC) networks pose a risk to successful WGS development and implementation.
- Interoperability and compatibility requirements compound the complexity of developing the control software for WGS. The Gapfiller Satellite Configuration Control Element (GSCCE) used to control WGS payloads must be interoperable with the Defense Satellite Communications System Operations Center (DSCSOC) network. An ongoing Army software development program is upgrading the DSCSOC network to a new ODOCS system. This is separate from the concurrent WGS program to produce the GSCCE. If the GSCCE and the ODOCS are not interoperable the DSCSOC operators will not be able to successfully establish communication networks with operational users.
- WGS and the Global Broadcast System (GBS) must be interoperable and compatible. GBS is fielding its support infrastructure to structure broadcasts and control the payloads on the UFO satellites. WGS payloads (at X and Ka-band) are proposed to be controlled by modified DSCSOCs, currently only capable of controlling X-band payloads. Interoperability between these two systems must be synergistic and not compete to ensure high-speed access for broadcast users.

# **PART VI**

## **OTHER DEFENSE PROGRAMS**



## **MEDIUM EXTENDED AIR DEFENSE SYSTEM (MEADS)**



The Medium Extended Air Defense System (MEADS) is designed to be a highly mobile air defense system to protect maneuver forces and fixed assets. The system should provide area and point defense capabilities against multiple, simultaneous, 360° attacks by ballistic missiles, large caliber rockets, fixed-wing and rotary-wing aircraft, unmanned aerial vehicles (UAVs), cruise missiles, tactical air-to-surface missiles (TASMs), and anti-radiation missiles (ARMs). It is required to be strategically deployable (C-130 roll on / roll off) and tactically mobile (able to keep up with the maneuver forces).

A MEADS battery will include rotating surveillance and fire control radars, launchers, Patriot Advanced Capability-3 (PAC-3) missiles, and battle management command, control, communications and intelligence elements. All system components will be employed in a distributed architecture using high-capacity tactical communications. Netted and distributed sensors will provide continuous, redundant, and optimized target tracking. MEADS will be interoperable with other Army, Joint Service, and allied systems expected to participate in joint/combined operations in the 21<sup>st</sup> Century.

Although the MEADS and Patriot air and missile defense systems have similar threat sets, Patriot employs the PAC-2 missile against many threats (aircraft, UAVs, TASMs, and ARMs), while MEADS will use the PAC-3 missile against all threats.

### **BACKGROUND INFORMATION**

MEADS is an international co-development program between the United States, Germany, and Italy. The material developer and contracting authority is the NATO MEADS Management Agency (NAMEADSMA). International direction and oversight is provided to NAMEADSMA by the three National Armaments Directors (USD(AT&L) for the United States) and the MEADS Steering Committee. The U.S. Steering Committee representative is the Army PEO for Air and Missile Defense. The U.S. MEADS National Product Office oversees U.S. requirements development and reports to the U.S. Steering Committee representative. U.S. oversight is accomplished through the IPT process. The international nature of the MEADS program adds additional complexity to the test strategy development process.

The MEADS program is now in a three-year Risk Reduction Effort (RRE), which began on July 10, 2001. It will enter the design and development phase after Milestone B, which is scheduled for

2QFY04. Milestone C is planned for FY09, with IOT&E to begin in FY10. The full-rate production decision is scheduled for FY12.

### **TEST & EVALUATION ACTIVITY**

Two U.S. T&E IPT meetings were held during this reporting period to begin planning the test program. The T&E IPT needs to develop a robust test strategy that builds on the PAC-3 missile testing conducted as part of the Patriot program. A U.S. Lethality Working Group has been formed to develop a U.S. LFT&E Strategy. T&E activity will be limited during RRE, but contractor testing will lead up to an RRE Exit Demonstration in which a prototype MEADS fire control radar will detect and track fixed-wing aircraft, and digital simulations of other MEADS elements will generate missile-fire solutions and conduct virtual intercepts.

### **TEST & EVALUATION ASSESSMENT**

The MEADS mission is complicated by having to operate in areas that can be densely populated with both friendly forces and threat targets. The MEADS system must acquire, track, and identify both friendly and threat targets, fuse the data, and then effectively engage and kill the threat targets. The difficulty associated with MEADS development is high.

Because of the requirement to engage and destroy a broader target set and a more diverse intercept space (360 degree coverage) than those of other missile defense systems, the T&E program will be complex. The MEADS test program will leverage PAC-3 missile testing, but the full extent of this testing is not yet known, since some PAC-3 capabilities are being deferred and the PAC-3 follow-on test program is not currently defined. The Patriot program will conduct little or no PAC-3 missile testing against much of the MEADS threat set. There are currently no plans to flight test PAC-3 missiles against ARMs, TASM, large caliber rockets, UAVs, rotary winged aircraft, or high altitude cruise missiles. Additionally, PAC-3 missile flight tests have only been limited to a few specific TBM threats.

MEADS is an international co-development program managed by a NATO agency that is not bound by U.S. laws and regulations. However, the U.S. acquisition community must ensure that the MEADS test program is adequate to assess the effectiveness, suitability, survivability, and lethality of the system against the entire U.S. MEADS threat set. The 1998 U.S. MEADS TEMP would be a valuable tool for facilitating the development of an international test and evaluation plan.

## **NATIONAL MISSILE DEFENSE (NMD) (GROUND-BASED MIDCOURSE DEFENSE)**

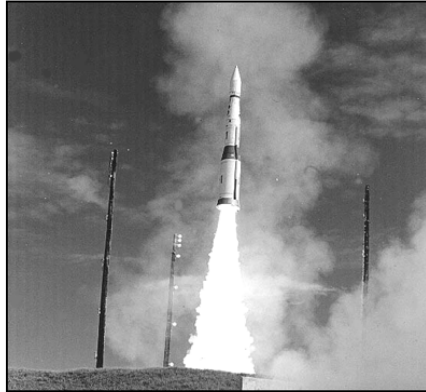

The title of the National Missile Defense program has been formally changed to Ground-Based Midcourse Defense (GMD). The mission of the GMD system is to defend all 50 United States against a limited strike of Intercontinental-class Ballistic Missiles (ICBMs) by adversaries from rest-of-world, or *rogue* nations, with a residual capability against small-scale unauthorized or accidental launches from existing nuclear powers. The system must perform detection, discrimination, battle management, and intercept functions, which require the integration of multiple sensor, communications, command and control, and weapon systems.

The exact GMD configuration is evolving, as options for a deployable system are being considered and the role of sea- and space-based defense architectures is being defined. The GMD system of record is an integrated collection of subsystems, referred to as Elements, that perform dedicated functions during an ICBM engagement. The system will include a Battle Management, Command, Control, and Communications (BMC<sup>3</sup>) element, four types of long-range sensors (the Defense Support Program and Space Based Infrared System satellites, Upgraded Early Warning Radar (UEWR), and a Ground-based X Band Radar (XBR)) and an arsenal of Ground-based Interceptors (GBIs). The BMC<sup>3</sup> will perform engagement planning and situation assessment while keeping a human-in-control, and serve to integrate the GBI and sensor operations through the In-Flight Interceptor Communications System (IFICS). The GBI is a silo-based, ICBM-class missile that delivers a Exoatmospheric Kill Vehicle (EKV) to a point above the atmosphere en route to engage a threat target cluster. After separation from the booster, the EKV flies to an intercept point provided prior to launch. In-flight communication events between the EKV and the ground provide updates on the intercept point and other parameters. After necessary diverts, the EKV activates infrared and visible sensors to acquire and track the target. The EKV uses its guidance, navigation and control functions, while employing its discrimination capability to identify and intercept the threat RV. After the intercept, ground- and space-based sensors continue to collect data so that a kill assessment can be made to evaluate the success or failure of the engagement.

### **BACKGROUND INFORMATION**

The previous acquisition strategy for GMD culminated in the Deployment Readiness Review (DRR) on August 3, 2000. Neither testing nor modeling and simulation produced adequate results to support a deployment decision. As a result, on September 1, 2000, the President announced that, based

on the information available to him, he could not conclude that there was enough confidence in the technology and operational effectiveness of the entire GMD system to move forward to deployment. He also asked the Secretary of Defense to continue a robust program of development and testing.

The Ballistic Missile Defense Organization is in the process of revising its approach to ballistic missile defense. The distinction between National and Theater Missile Defense will be de-emphasized, as focus will be placed on different phases in the engagement process: boost phase, midcourse and terminal phase. The midcourse phase may also eventually incorporate sea-based components to kill incoming ICBMs. The system will be developed in block increments, with the first segment being termed the Initial Capability, which is unchanged from the old C1 program (a few RVs with simple countermeasures). Additionally, the program is modifying its development planning to adopt a *capability* vs. a *requirements* oriented approach. While the objective operational requirements are the ultimate goal, the utility of the incremental blocks will be assessed for possible deployment against emerging threats.

## **TEST & EVALUATION ACTIVITY**

As the program redefines itself, test planning is in a similar state of flux. The existing TEMP is no longer an accurate representation of the GMD T&E program and needs to be updated. Several test planning initiatives (such as the Block 04/06 Testbed and the Expanded Testbed Plan-2) are scheduled for completion in late 1QFY02. These test planning initiatives are a result of DOT&E FY00 Annual Report recommendations and address the previously identified flight test constraints and operational realism concerns. The use of the Kodiak Launch Complex specifically addresses the need for Multiple Simultaneous Engagement testing. The next TEMP revision will begin upon completion of these efforts to incorporate the new test range capabilities.

GMD T&E will continue to leverage flight, ground and laboratory testing, modeling and simulation and User Exercises at the Joint National Integration Center to assess Human-In-Control functionality. In that regard, BMDO is considering expanding test range capabilities to address previously recognized inadequacies in the flight test program that include restricted engagement geometries, inadequate sensor coverage and limited operational realism. The expanded test range will integrate additional interceptor and target launch locations, midcourse radar installation, a mid-Pacific IFICS Data Terminal and multiple simultaneous engagement capabilities. The program plans to continue piggybacking on Minuteman operational evaluation launches that would carry a more varied and challenging target suite to examine discrimination issues. Ground Testing will continue at the Integrated Systems Test Capability (ISTC) and will expand to Boeing's new Prime Consolidated Integration Laboratory (PCIL). More advanced representations of the system elements will be used in the PCIL and ISTC. Hardware-In-The-Loop (HWIL) testing of the EKV is still limited and needs an aggressive approach to adequately test the discrimination and homing functions. EKV HWIL testing will begin in FY03 at the Arnold Engineering Development Facility.

Near-term GMD T&E planning focuses on demonstrating end-to-end integrated system performance. The principal functions to be demonstrated include target detection, acquisition, tracking, correlation, and handover, real-time discrimination, kill assessment, battle management and engagement planning, component integration and interface compatibility, human-in-control operations, interoperability with other national defense assets, and system lethality. The principal tools used to assess performance of these functions are flight tests, ground tests, and computer simulations. The key system simulation, the Lead System Integrator Integrated Distributed Simulation (LIDS), has continued



its slow evolution. A reduced scope LIDS Build 5 has been delivered to the government and its performance is being assessed.

## **FLIGHT TESTING**

System elements will continue to be integrated and tested in a series of Integrated Flight Tests (IFTs). Initially, these tests necessarily relied heavily on the use of surrogates. As the system design matures, more prototypes are being introduced into the test architecture. However, some surrogates (including the interceptor booster and FPQ-14/C-band transponder for midcourse tracking) will continue to be needed for the next several tests until the tactical booster is proven out and until new tracking software is available.

Two GMD flight tests were conducted in FY01. IFT-6, was conducted on July 14, 2001 and IFT-7 was conducted on December 3, 2001. As replays of IFT-5 (with respect to engagement conditions and system configuration), both attempts successfully intercepted the target RVs and demonstrated end-to-end GMD system functionality with surrogate and prototype elements in a configuration representative of the system to be deployed. The only objective not satisfied in IFT-6 was real-time hit assessment by the GBR-P, which incorrectly reported a MISS. A software fix for this anomaly was implemented prior to IFT-7. Its performance is still being assessed as of the writing of this report. Prior to FY01, tests included a successful intercept in IFT-3 followed by two successive failures in IFT-4 & 5. IFT-1 & 2 were successful non-intercept fly-by tests.

## **GROUND TESTING**

Integrated Ground Tests (IGTs) performed at the ISTC use a combination of models, software, and prototype hardware components to assess the deployable system in stressing environments and operational scenarios not achievable in actual flight tests. While the execution of the IGTs is improving through the addition of newer and more representative versions of GMD element software/hardware and improvement to the physical realism of the simulated environment, current IGT results need to be interpreted with caution. Since the designs of each of the GMD elements are not yet mature relative to the Initial Capability objectives, neither are their software/hardware representations in the ISTC. For example, the tactical booster design and performance parameters have not yet been defined, thus deployed booster performance during an engagement cannot be accurately modeled. Similarly, tactical discrimination algorithms for the EKV are still under development. Limitations in the ISTC test environment and the GBR-P simulation software necessitates thinning the number of threats and other objects from the design-to scenarios, resulting in a significant reduction in complexity for both XBR and EKV discrimination functions. Consequently, the GMD Prime Contractor is currently using the IGTs for integration purposes rather than to assess system performance. The OTAs, on the other hand, will still need to use them for limited performance assessments and will have to do so with the current limitations of the ISTC.

IGT-6 was the only IGT conducted in FY01. It demonstrated the successful integration of the BMC3, GBR-P/XBR and UEWR simulations and, for the first time, a GBI simulation. Five different threat scenarios were used in the runs-for-record, each of which incorporated only a single RV and limited debris. All scenarios were successfully executed. Despite their limitations, data collected during IGT-6 were beneficial and may have partially contributed to the success of IFT-6 since IGT data analysis identified some issues associated with the processing of In Flight Target Updates and infrared data on the simulated EKVs. The ISTC will host IGTs through FY03. Its fidelity and complexity are expected to increase to provide a more operationally realistic environment to assess GMD functionality. After FY03, the Boeing PCIL will host ground tests similar to the IGTs.

Pre-mission and post-flight reconstruction testing were conducted at the ISTC for IFT-6. Pre-mission Test-6 provided risk reduction for the flight test by exercising the actual flight test software in both nominal and off-nominal scenarios.

## **LETHALITY TESTING**

The Live Fire Test & Evaluation (LFT&E) Working Group, a subgroup of the GMD Lethality IPT, develops the LFT&E strategy for GMD. LFT&E activities will include flight testing, sub-scale light-gas-gun (LGG) testing, and simulation analyses. Sled tests could possibly be conducted to examine full-scale intercepts at the very low end of the intercept velocity range.

The GMD lethality evaluation effort has thus far concentrated on lethality test and analysis activities to support the development and accreditation of simulations. An initial series of quarter-scale LGG tests was successfully completed on December 7, 2000. Additional LGG testing is planned. The reduced scale LGG testing is a significant part of the evolving GMD LFT&E strategy. Its main objective is to generate lethality data to support validation of hydrocode predictions and to provide test bases for specifying modeling and simulation anchor points. For a given target and applicable intercept conditions, the anchor points define kill zones for prediction on GMD lethality. The earlier LGG test series generated lethality data against scaled targets for a specified impact velocity and a variety of hitpoints and strike angles. These tests also generated data to verify kill assessment instrumentation for LFT&E flight tests and supported development of kill assessment methodology. There were twelve Equations-of-State gas gun tests in FY01 to validate hydrocode developed in FY00. IFT-6 resulted in an intercept of the target. Lethality data collected during the test is being assessed by DOT&E.

## **TEST & EVALUATION ASSESSMENT**

Despite the revised program, the schedule established for the GMD Program presents a major challenge. In spite of this, the program has tried to maintain an event rather than schedule driven focus in FY01.

Previous DOT&E Annual Reports to Congress identified a number of risks that could have significant impact on the GMD T&E program's ability to test, analyze, and evaluate system performance and to prepare for operational testing. The degree to which those risk areas have changed from the last reporting cycle are addressed below:

- **Limited engagement conditions:** As addressed above, the plan to develop an expanded test range will attempt to minimize the constraints to tactically realistic scenarios. Additionally, fielding an initial testbed configuration would enhance the capability to examine multiple engagement configurations.
- **GBI booster testing:** In order to increase the current Boost Vehicle (BV) burnout velocity margin for the most stressing engagement scenarios, a redirected BV program has initiated a competition for a higher performance Alternate BV (ABV). A down select to two ABV designs, that may, or may not, include a variant of the current BV design, is planned for November 2001. First use of the ABV in an IFT has been scheduled for IFT-16 in February 2004.

- Limitations of ground testing: The ISTC currently provides a venue for testing element integration and limited system performance assessments via the IGTs. Program schedules show the current ISTC activities ending in FY03. After FY03, Integrated Mission Tests (IMTs) will be conducted at the PCIL, a Boeing facility that promises an advanced *plug and play* integrated HWIL simulation capability requiring no modifications to element software or hardware. The PCIL is intended to be an integration tool, not a tool for performance assessment. If the PCIL is not suitable for performance assessment, the issue of how LIDS would be anchored arises, since flight testing will never be able to reproduce the intensity of the required design-to scenarios. This would leave a non-validated LIDS as the only system-level performance assessment tool.
- Target suite: IFT-6 still relied on a large balloon as the sole decoy. This is appropriate for early developmental testing to exercise basic discrimination functions, but flight tests need to start incorporating decoys that more closely match the target RV. Test targets of the current program do not represent the complete *design-to* threat space and are not representative of the full spectrum of sensor discrimination requirements. Much of this limitation, however, is attributable to the lack of information surrounding the real threat. As the knowledge of the threat evolves, the risk in this area should decrease slightly.
- Multiple target testing: The program has intends to conduct multiple simultaneous engagements prior to completion of the flight tests under contract with Boeing. Since a new TEMP has not been produced, this decision is not yet formally documented nor funded.
- Spare test articles: The previous TEMP identified a lack of spare test articles due to a resource allocation trade-off. Current program planning uses a rolling spare concept in which the test target for the next test flight serves as the backup for the current flight test. This approach will mitigate the spare target problem; however, spare test articles are still recommended for the interceptor and EKV, where test failures could have major schedule impacts.
- Limitations of ground lethality testing: Currently, ground lethality test data has to be collected from light-gas-gun tests of reduced-scale (1:4) replicas of EKV surrogates and targets. These gas gun tests are conducted at the lower-end (six kilometers per second or less) of the intercept velocity spectrum and are used to validate hydrocode computer simulations for analysis of the higher velocity tactical collisions. There is no ground test facility capable of propelling EKVs or their full-scale replicas against targets at the closing velocities expected for GMD intercepts. These closing velocities will exceed 7 kilometers per second (KPS) and in some cases will even exceed 10 KPS. Existing full-scale sled track facilities have only approached 3 KPS. However, while limited, these facilities still provide the ability to conduct testing of full-scale components.
- Modeling & Simulation. Modeling and simulation (M&S) efforts have been reoriented. The current BMDO plan calls for the M&S maturity to evolve consistent with the incremental block development of the system rather than with advanced planning and analysis. Specifically, key functionalities such as discrimination performance (both radar and IR) against more advanced decoys and countermeasures, engagement planning performance against more complex threats, integration of SBIRS/Low, and overall system performance and architecture suitability to meet an objective threat level cannot be predicted. Focusing M&S development in support of incremental block development significantly reduces the near-term software and incremental block development risks but substantially increases the ability to predict ultimate system performance.

## **LESSONS LEARNED**

DOT&E wishes to reemphasize two particular areas from its report to the DRR:

- Several factors drive the need for a focused hardware-in-the-loop approach in parallel with the flight test program. They include the risk of a flight test failure for a myriad of reasons, the difficulty in deploying adequate and realistic flight countermeasures in a flight test and speculation on the EKV's ability to discriminate countermeasures. DOT&E strongly recommends the JPO continue its effort to develop a flexible, comprehensive hardware-in-the-loop facility, which can present a high fidelity representation of the threat target for designing and testing of the EKV.
- As noted above, flight tests still rely on surrogate elements. The most significant of these surrogates the FPQ-14 radar whose data are needed to produce the critical Weapon Task Plan that contains the initial engagement parameters for the interceptor. Use of this radar obviously degrades test realism. Furthermore, since the FPQ-14 tracks a transponder on the target, program critics can allege that the tests are rigged through the use of a *beacon*. DOT&E strongly supports the placement of an X-Band Radar in a mid-course test vicinity to increase both the realism and variety of test geometries that can be created.

## **NAVY AREA THEATER BALLISTIC MISSILE DEFENSE (NATBMD)**



The Navy Area Theater Ballistic Missile Defense (NATBMD) system is intended to protect amphibious assault forces and coastal cities from short-to medium-range ballistic missiles, while maintaining current Standard Missile capabilities against manned aircraft and cruise missiles. The NATBMD system consists of the following:

- Standard Missile-2 (SM-2) Block IVA, which incorporates an infrared (IR) seeker, a radio frequency adjunct sensor (RFAS), and a new autopilot to the proven Block IV airframe. Additionally, new predictive fuzing (forward looking fuze or FLF) algorithms provide highly accurate burst solutions well before intercept to place warhead fragments on the target.
- Upgrades to the AEGIS Weapon System (AWS) to enable tracking and engagement of high-speed, low radar cross-section, theater ballistic missiles (TBMs).
- Upgraded Link-16 message set that provides interoperability with Navy, other Service Theater Ballistic Missile Defense (TBMD) systems, and command and control systems.

### **BACKGROUND INFORMATION**

The NATBMD system entered Engineering and Manufacturing Development (EMD) in March 1997. The EMD test phase will examine performance against TBMs, aircraft, cruise missiles, multiple targets, and debris and countermeasure environments. NATBMD began EMD flight-testing in FY00 with two successful Control Test Vehicle (CTV) firings at the White Sands Missile Range (WSMR). In FY01, EMD ground and flight tests were hampered by problems with the integration of guidance section hardware and software components. These problems have resulted in a delay of over one year in WSMR flight-testing.

Because of the delays, the NATBMD program breached the majority of its cost and schedule parameters in FY01. Due to scope of this program breach, USD AT&L did not certify the program as required under Nunn-McCurdy legislation. The NATBMD program was terminated on December 14, 2001.

## **TEST & EVALUATION ACTIVITY**

The TEMP was approved in February 1997. Significant progress has been made toward an updated TEMP, which proposes a six-phase flight test program in support of an FY05 MS III. The test program includes missile firings at WSMR and the Pacific Missile Range Facility (PMRF) against real and surrogate TBMs and cruise missiles, tracking exercises, multiple simultaneous engagements, dual salvo intercepts, and raid rate scenarios. Seven tests during OPEVAL will complete the test program.

No flight tests occurred in FY01. The next WSMR shot, TBM Fly-By, is scheduled for 2QFY02, and will provide the first in-flight test of a Block IVA guidance section with integrated flight hardware. The follow-on TBM shots will attempt to intercept a target using a fully functional FLF.

In February 2001, the NATBMD program participated in the Theater Missile Defense Critical Measurements Program-3B (TCMP-3B) at Kwajalein Missile Range. TCMP-3B provided an opportunity to collect RF and IR data on a high fidelity threat-representative re-entry vehicle. During TCMP-3B, a LINEBACKER test ship successfully gathered tracking data for AWS assessment. The LINEBACKER system consists of a LINEBACKER version of the AWS software installed on two cruisers. Unlike the objective system, which will engage all threats (unitary and separating) simultaneously, LINEBACKER has either a TBMD capability engaging unitary targets *or* an air-defense capability. Another NATBMD participant in TCMP-3B included an SM-2 Block IVA spectral imager on Gagan Island, which collected images for endo-atmospheric IR characterization.

## **TEST & EVALUATION ASSESSMENT**

The Navy has not demonstrated, via live testing, an integrated system (AWS and missile) capable of acquiring, tracking, and intercepting TBMs. LINEBACKER demonstrated that the AEGIS SPY-1 radar can track a TBM and, in a separate test, an early prototype version of the SM-2 Block IVA demonstrated that it could engage and intercept a Lance target using guidance data from WSMR tracking instrumentation. A number of technical challenges exist:

- SM-2 Block IVA guidance section integration: The IR seeker and RFAS are unique to the SM-2 Block IVA and are the primary FLF sensors. Integration of the FLF sensors and software has proven difficult. Because ground tests alone cannot fully assess FLF adequacy to meet the fuze timing requirements, the FLF will remain a risk until it is fully flight-tested.
- AWS B/L 6.3 computer program complexity and development: The AWS B/L 6.3 computer program may have difficulties maintaining both TBM and air-defense missions given the high radar loading levels required for multiple, high-speed, low radar cross-section TBM targets. Maintaining AWS B/L 6.3 computer program stability, mainly in the SPY radar element, during performance testing has been a problem.
- Linear Search and Track Processor (LSTP) development: The LSTP is an adjunct processor that improves the object resolution and detection range of the AEGIS radar. This processor is required for resolving closely spaced objects at long range. The LSTP has experienced stability problems under high track loads when integrated with the SPY radar control computer in the test environment.

Based on an assessment of the discrimination challenges posed by certain threats, DOT&E requested the addition of a missile shot to the flight test matrix to assess NATBMD discrimination

performance. In 1QFY01, the Navy conducted a study on the feasibility of adding a discrimination shot to the test-flight matrix. The Navy study suggests that NATBMD will have heretofore-unexpected performance capability against these certain threats. A flight test was planned for DT/OT to examine this capability.

The proposed restructure plan opened up a previously compressed flight test schedule and allowed more time to review test data and incorporate any changes needed. Previously, to stay on schedule, the NATBMD program both removed shots from the flight test matrix and deferred risk to later flights. The effect was to increase overall program risk by delaying the assessment of key NATBMD technical elements.

As part of the restructure, the program proposed to shift later WSMR shots to PMRF given early success to reduce risk for follow-on at-sea testing. DOT&E supported this approach as long as these shots added to, but did not replace, the scheduled at-sea tests. A limitation of an early move to at-sea testing was the inability to examine debris in assessing LFT&E requirements. The effect of the restructure on the deployment of AWS B/L 6.3 ships was also a concern. To maintain the deployment schedules, some AWS B/L 6.3 ships would have likely deployed without TBMD capability.

The content of FOT&E testing in the TEMP and the need to coordinate the Navy Area FOT&E test strategy with the DDG51 and AEGIS AN/SPY-1D (V) programs was an area of concern for DOT&E. The cost of the FOT&E for NATBMD was a factor in USD AT&L's decision not to certify the program.

This Page Is Intentionally Left Blank



## NAVY THEATER WIDE / SEA BASED MID-COURSE (NTW/SBMC)



The Navy Theater Wide/Sea based Mid-course (NTW/SBMC) system is designed to protect U.S. forces and population areas from a ballistic missile threat. Its mission is to provide an Exo-atmospheric Hit To Kill Sea Based Mid-course capability as an element of DOD's newly implemented Ballistic Missile Defense System (BMDS). The NTW/SBMC capability will maximize defense-in-depth by acting synergistically with the boost, ground based midcourse and terminal defense layers of the BMDS. NTW/SBMC will provide the capability to intercept Theater Ballistic Missiles (TBMs) from exo-atmospheric ascent phase through exo-atmospheric descent.

The NTW/SBMC program consists of the Standard Missile-3 (SM-3) and upgrades to the AEGIS Weapon System (AWS). The SM-3 evolves from the SM-2 Block IV booster and sustainer motor by adding a third-stage rocket motor (TSRM) and fourth-stage kinetic warhead (KW) with a solid-fuel divert and attitude control system (SDACS) guided by an infrared (IR) sensor. The AWS will be modified to enable longer-range, exo-atmospheric TBM detection, tracking, discrimination, and engagement.

The NTW/SBMC program specifies Block I and Block II versions of the NTW/SBMC system. The Block I system uses an SM-3 missile and an upgraded AWS that includes high-range resolution for radio frequency (RF) discrimination capability against separating targets. The Block II system incorporates major upgrades to Block I for both the SM-3 and AWS. Before the start of Block II T&E, NTW/SBMC faces significant challenges with the development and integration of several non-legacy components:

- SM-3 axial propulsion – Block II will replace the ALI SM-3 second stage with a new larger rocket motor. The increased SM-3 burnout velocity will provide greater standoff capability, increased operation areas for advanced threats, and greater ascent phase capability.
- SM-3 KW IR seeker – For Block II, a two-color IR sensor, capable of measuring temperature and emissivity-area, will replace the Block I single-color IR sensor. A two-color sensor will bolster discrimination capability against countermeasures and debris.
- SM-3 KW signal processor – Block II will use an upgraded signal processor with increased throughput over the Block I signal processor. The upgrade will increase the number of objects discriminated in the field of view and provide higher raid density capability.

- SM-3 KW DACS – An advanced Block II DACS will replace the SDACS of the ALI/Block I system. Advanced DACS options include solid-fuel extended-burn and/or extended-length DACS, liquid-fuel DACS, or a liquid-/solid-fuel hybrid system. The greater Block II divert capability will increase operating time and divert distance and provide increased containment of dispersed threat clouds and longer-range separating threats.
- AWS – Block II will modify AWS with ship add-on S- and X-band radars and an upgraded signal processor for greater object resolution and detection range. Proposed dual-band radar suites consist of S-band solid-state SPY radar and an X-band high power discriminator.

## **BACKGROUND INFORMATION**

The NTW/SBMC program is comprised of two principal efforts. The first is the continued testing and completion of the Navy AEGIS Lightweight Exo-Atmospheric Projectile (LEAP) Intercept (ALI) Flight Demonstration Program that is a series of near term flight tests occurring in FY01 and FY02 that will demonstrate guidance to hit a ballistic missile target in the exo-atmosphere. The second principal effort is a concept definition phase that will focus on developing a more capable NTW/SBMC system for deployment in the FY08-FY10 timeframe.

Prior to FY01, the NTW/SBMC program had attempted three flights [Control Test Vehicle (CTV) -1 and -1A and Flight Test Round-1 (FTR-1)] of ten scheduled ALI flight tests. CTV-1 occurred in September 1997 and sought to demonstrate the capability of a two-stage SM-2 Block IV missile to fly through the high altitude second-/third-stage separation envelope required for an intercept mission. CTV-1 was not successful because of a hardware failure in the SM-2 steering control section. CTV-1A occurred in September 1999 and successfully demonstrated airframe stability and control of the SM-3 missile through second-/third-stage separation. FTR-1 was conducted in July 2000, with the primary objective to maintain airframe stability and control of the SM-3 through KW separation. The SM-3 third-stage failed to separate from the second stage, and the primary objective was not achieved.

In 1QFY01, a comprehensive study of the NTW/SBMC program concluded that the Block I system is essentially “dead-ended engineering” because it does not directly lead to the development of a Block II system. In addition, inherent limitations in the Block I radar and SM-3 missile were found to restrict the threat that could be countered. The study therefore proposed that the NTW/SBMC program complete the ALI phase, skip Block I development, and proceed directly to Block II. The FY 2003 President’s Budget Submission adjusted the NTW/SBMC program by terminating Block I development and shifting the focus to fielding of Block II in the FY08-10 timeframe.

In response to this redirection, PM working groups have been addressing Block II system concept definition (system performance, elements, and functions), requirements (mission and threat analysis), and test strategy. A final revised NTW/SBMC program plan has not been finalized. Proposed plans to develop Block II call for a phased evolution of the ALI missile and AWS by modifying the propulsion stack and KW and refitting NTW/SBMC ships with a dual-band radar suite.

If funding becomes available, the option exists to field a Block I contingency system consisting of a TBMD-only ship to counter non-separating and simple separating threats. Despite the current lack of program funding beyond the end of the ALI phase in FY02, T&E planning for the NTW/SBMC Block I contingency system continues in accordance with the Program of Record TEMP until a revised program plan is approved. In particular, scenario and target development planning for post-ALI threat-

representative target testing is currently underway. Early success during ALI marked by two descent phase intercepts could accelerate the start of such testing.

## **TEST & EVALUATION ACTIVITY**

In January 2001, the NTW/SBMC program successfully completed the FTR-1A flight test. The primary objective of FTR-1A was to demonstrate third-stage airframe stability and control of an FTR-1A-configured SM-3 missile through the nominal time of KW separation. The FTR-1A mission differed from previous ALI flights in that the SM-3 missile was launched against a live ARIES target, or Target Test Vehicle-2 (TTV-2), vice a simulated target generated by the test ship. Although the KW had no divert capability, the SM-3 third-stage placed the KW within the desired divert envelope, which enabled the IR sensor onboard the KW to acquire the target and obtain images for post-flight analysis.

The follow-on Flight Mission-2 (FM-) shot – a KW characterization flight test – is scheduled to occur in 2QFY02. The primary objective of the FM-2 mission will be to demonstrate KW guidance, navigation, and control against a live TTV. FM-2 will be followed by the first intercept flight test, FM-3.

The NTW/SBMC program participated in two target launch events in FY01: Theater Missile Defense Critical Measurements Program-3B (TCMP-3B) and Quick Reaction Launch Vehicle-1 (QRLV-1). These events provided an opportunity to collect high quality RF and IR data on a high fidelity threat-representative re-entry vehicle. During TCMP-3B, the NTW/SBMC program collected ascent phase TBM data with NTW/SBMC sensors for end-to-end simulation validation. NTW/SBMC sensors included the high range resolution radar test bed and SM-3 IR sensors. Valuable data was obtained to evaluate software algorithms for aim point selection and RF/IR discrimination and correlation. QRLV-1 was a target risk reduction flight for possible testing of the Block I contingency system against a unitary threat-representative target following ALI. The QRLV-1 target was identical to the ALI TTV target except, unlike ALI, the target flew a threat-representative trajectory. The ALI cruiser, USS LAKE ERIE, successfully tracked the QRLV-1 target from the ascent phase intercept position.

A light gas gun test series was conducted in FY01. Three direct hit sled tests were scheduled, but the first test in July 2001 resulted in a failure that delayed the series. NTW/SBMC LFT&E tests and analyses are scheduled to continue through FY03.

## **TEST & EVALUATION ASSESSMENT**

The ALI project objective is to demonstrate the ability to hit a TBM target in the exo-atmosphere. The ALI flight test scenarios are not operationally realistic or functionally stressing. Additionally, neither are the test targets threat-representative, nor are the AWS and SM-3 missile fully functional versions of the Block I system. In particular, the SPY-1 signal processor does not afford adequate range resolution for multi-object discrimination of separating threats, nor is the ALI SM-3 missile equipped with multi-object discrimination or aim point selection capability.

As reported in past DOT&E annual reports, early fielding of Block I at the expense of developing Block II technologies has been a DOT&E concern. By enhancing the NTW/SBMC discrimination capability and interceptor velocity and terminal divert, the combination of Block II SM-3 and AWS modifications expands the NTW/SBMC threat set to include faster, longer range targets and countermeasure-capable, separating targets not previously addressed with the Block I system.

This Page Is Intentionally Left Blank

## **PATRIOT ADVANCED CAPABILITY-3 (PAC-3)**



The PATRIOT air defense system that uses guided missiles to engage and destroy air-breathing targets (ABTs) and tactical ballistic missiles (TBMs). PATRIOT Advanced Capability 3 (PAC-3), Configuration-3, is the latest version. A PAC-3 battery will include a multi-function phased-array radar, an engagement control station, and communications relay groups for communicating with remote launchers and the battalion headquarters. Each PAC-3 battery will have eight launchers. Some of the launchers will have four PAC-2 blast-fragmentation warhead missiles, the primary interceptor against ABTs, while other launchers will have 16 new hit-to-kill PAC-3 missiles, the primary interceptor against TBMs. The Army has not yet determined the final distribution.

### **BACKGROUND INFORMATION**

The PAC-3 Operational Requirement Document (ORD) was developed after the Persian Gulf War to improve the PATRIOT system, including a new PAC-3 hit-to-kill missile. Flight testing of the PAC-3 missile began in 1997 and had successful intercepts against three TBMs and two cruise missiles between March 1999 and July 2000.

The PAC-3 Limited User Test (LUT) was conducted during March-June 2000. The LUT revealed serious deficiencies in ground system suitability, as well as major effectiveness issues. These included instances when the system misidentified objects, engaged debris, or failed to engage threatening TBMs. There was a new software drop in September 2000 to correct some of these problems.

### **TEST & EVALUATION ACTIVITY**

LUT regression testing was conducted in 1QFY01 to address the deficiencies in the FY00 LUT.

The PAC-3 DT-6 flight test was performed in October 2000. In DT-6, a PAC-3 missile intercepted a TBM target at the same time that a PAC-2 missile engaged a fixed-wing drone. The PAC-3 TBM intercept was successful, but a missile hardware failure caused the PAC-2 missile to detonate too late to destroy the drone.

The PAC-3 DT-8 flight test was performed in March 2001 (DT-7 flight test occurred in FY00). In DT-8, two PAC-3 missiles were ripple fired to engage one TBM target while one PAC-2 missile

engaged a PATRIOT missile emulating a short-range threat TBM. Both intercepts were successful. The second PAC-3 missile that was ripple fired did not detect and track any debris from the intercept and therefore self-destructed.

The PAC-3 DT/OT-9 flight test was performed in July 2001. In DT/OT-9, one PAC-3 missile destroyed a jamming full-scale fixed-wing target while another PAC-3 missile failed to intercept a TBM target. An electrical anomaly in the missile's communications bus disrupted communications between missile subsystems and prevented homing in on the target for an intercept. This was the first miss for the PAC-3 missile. The root cause of the failure has not been specifically identified, but the symptoms of the failure are known and have been replicated in the software lab. Software modifications have been implemented to reduce the likelihood of this error. The PAC-3 missile that engaged the TBM had a new conductive topcoat, which was developed to increase the radio frequency signal strength received by the missile during flight. The uplink signal power was significantly improved compared to previous flight tests. Another first for the PAC-3 flight test program was that tactical unit soldier crews operated two of the three fire units during DT/OT-9.

The last PAC-3 developmental flight-test, DT/OT-10, was performed in October 2001. In DT/OT-10, a PAC-3 missile intercepted a cruise missile target at the same time that a PAC-2 missile engaged a fixed-wing drone. Both intercepts were successful.

The PAC-3 LFT&E Program concluded the full-scale sled test series with the replication of flight test DT-6 intercept conditions to compare the lethality observed in sled testing to a TBM intercept. Lethality assessments were performed on the flight test targets discussed above and will be performed on all remaining flight test targets. The live fire light gas gun and high-speed sled TBM lethality tests are complete.

PAC-3 Configuration-3+ Developmental Test and Evaluation (CDTE-3+) was conducted in 4QFY01 and 1QFY02 and consisted of large-scale search and track exercises, hardware-in-the-loop tests, and reliability testing. Analysis of the CDTE-3+ data is incomplete, but preliminary results indicate there are several software problems that must be fixed prior to IOT&E.

## **TEST & EVALUATION ASSESSMENT**

The PAC-3 system will not meet all of its Key Performance Parameters (KPP) prior to Milestone III. The Army plans to address these shortfalls in an evolutionary development program. The Joint Requirements Oversight Council has approved this approach but considers the KPPs essential to meet the mission need. Since the PAC-3 system will not meet all of its KPP requirements prior to Milestone III, a Follow-On Test Program (FOTP) is required. The FOTP will consist of flight tests, hardware-in-the-loop ground tests, and field exercises. It is particularly important to plan the FOTP flight-testing to evaluate the missile's capability against deferred PAC-3 requirements, cost-reduction initiative hardware changes to the PAC-3 missile, and potential reactive threats and threat countermeasures.

Since 1999, the PAC-3 missile has hit five of six TBM targets, three of three cruise missile targets, and one of one drone fixed-wing aircraft target. PAC-3 tests to date have been in the heart of the PAC-3 missile performance envelope, which is where the PAC-3 system is designed to take all engagements possible. DOT&E is asking that the FOTP include engagements closer to the boundaries of the performance envelope. These tests will permit more comprehensive validation of the simulations used to predict the PAC-3 system performance, and thus provides higher confidence in the PAC-3 system performance assessments in areas untested.

There must be funding for additional White Sands Missile Range PAC-3 range safety telemetry frequencies to ensure that at least four PAC-3 missiles can be in flight at one time during a flight test. There are currently only two PAC-3 telemetry frequencies, which prevented a second PAC-3 missile from being fired at the TBM target in DT/OT-9. Tactically, there should have been two missiles fired at the TBM. The program office believes that a second PAC-3 missile would probably have intercepted the TBM despite the failure of the first missile.

The PAC-3 Configuration-3 ground system has had significant reliability problems, but reliability has improved over time. In CDTE-3 (FY99), the fire unit critical mission failure rate was 3.4 times larger than the threshold ORD requirement. During the LUT (FY00), the fire unit critical mission failure rate was 1.7 times larger than the threshold requirement. Preliminary results from CDTE-3+ (FY01) indicate that the reliability has significantly improved again.

Survivability is a critical missile defense system issue. The PAC-3 Configuration-3 ground system must be tested against a live anti-radiation missile (ARM) prior to Milestone III. This test will be used to validate the simulation used to assess whether the PAC-3 system meets its survivability requirement against ARMs.

The LFT&E program against TBMs was robust and characterized the damage inflicted by the PAC-3 interceptor on its threat target set. Lethality testing against air breathing threat surrogate targets was also conducted since they are secondary targets for PAC-3 missile. The LFT&E program has demonstrated that the PAC-3 missile intercept may not kill all warhead submunitions, and that there will probably be some ground effects following an intercept by the PAC-3 missile. DOT&E is working with BMDO to define and develop a ground effects predictive tool, the Post Engagement Ground Effects Model (PEGEM), to help quantify any ground effects.

## **LESSONS LEARNED**

A large part of the success of the PAC-3 missile in flight tests derives from the program office's commitment to mitigating flight test risks through extensive ground testing.

This Page Is Intentionally Left Blank



## **THEATER HIGH ALTITUDE AREA DEFENSE (THAAD)**

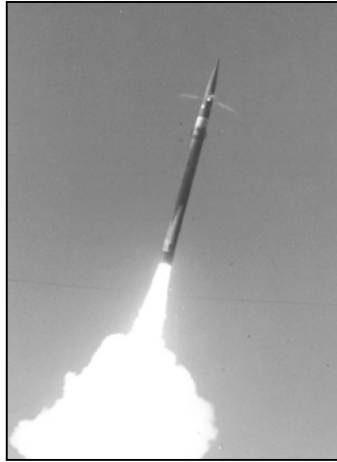

The Theater High Altitude Area Defense (THAAD) is a mobile ground-based Theater Ballistic Missile Defense (TBMD) system designed to protect forward-deployed military forces, population centers, and civilian assets. THAAD intercepts ballistic missiles using hit-to-kill technology at either endoatmospheric or exoatmospheric altitudes. THAAD provides upper-tier missile defense in concert with the lower-tier PATRIOT Advanced Capability-3 (PAC-3). THAAD must be fielded with a lower tier system to provide near leak-proof protection.

The THAAD system consists of mobile launchers; interceptors; radars; Battle Management/Command, Control, Communications, and Intelligence (BM/C<sup>3</sup>I) units; and ground support equipment. The launcher system is based on a modified U.S. Army palletized loading system truck. The interceptor consists of a single-stage, solid-fuel booster with thrust vector control and a separating kill vehicle that uses an infrared seeker and divert thrusters for terminal guidance and control. The THAAD X-band, phased-array radar performs search and track functions and also delivers mid-course guidance target updates to the kill vehicle. The THAAD BM/C<sup>3</sup>I segment controls and integrates all THAAD weapon system components.

The THAAD program is proposing two sequenced Engineering and Manufacturing Development (EMD) configurations. Configuration 1 is intended to meet the seven key performance parameters (KPPs) of threat, range and radar cross-section, defended area, protection effectiveness, lethality, kill probability, and interoperability. The missile will also be delivered as part of Configuration 1. The Configuration 2 system will deliver additional software development for the BMC<sup>3</sup>I and Radar.

### **BACKGROUND INFORMATION**

THAAD entered Program Development and Risk Reduction (PDRR, formerly called Dem/Val) in 1992. THAAD entered Engineering and Manufacturing Development (EMD) in June 2000. THAAD has an approved TEMP for EMD. Currently, Configuration 1 will enter production in FY09. Configuration 2 is planned to enter production in FY12.

The THAAD PDRR T&E program performed system flight testing (at White Sands Missile Range, NM, 1995 through 1999), hardware-in-the-loop (HWIL) testing, element ground testing, and digital simulations. The program completed 11-PDRR flight tests, including eight intercept attempts. The first six of the eight intercept attempts failed. THAAD achieved “hit-to-kill” target intercepts on the last two flight tests.

Subsequently, the Department authorized the THAAD program to enter the EMD phase. Developmental tests in EMD are planned at White Sands and Kwajalein Missile Ranges to prove out the new system redesign prior to committing to the production configuration. The THAAD missile redesign features implemented between PDRR and EMD include a new missile mission computer, elimination of course elevation gimbal gyro, a new Divert and Attitude Control System (DACS) with 40 percent more fuel and 10 percent more nozzle thrust, and an improved booster thrust vector control system.

THAAD’s PDRR lethality test activities included both Light Gas Gun (LGG) and high-speed sled testing, focusing on emerging targets specifically identified in the THAAD System Threat Assessment Report (STAR). In FY98 and FY99, the Army conducted a series of 12 LGG tests against submunition targets at the University of Alabama-Huntsville (UAH) facility (at Redstone Arsenal). These tests showed that THAAD is lethal against a submunition target under a wide range of conditions. During FY95, the program conducted 15 sled tests at Holloman AFB, NM, against a static, threat-representative target to study THAAD endgame lethality. In October 1996, 10 quarter-scale LGG tests were conducted at UAH. These lethality tests provided the baseline for planning formal LFT&E for EMD. In 1996, DOT&E approved THAAD’s live fire strategy.

The Army and OSD test and evaluation communities participated throughout PDRR test planning and execution using element and system-level data to support the EMD decision.

## **TEST & EVALUATION ACTIVITY**

There was very little test and evaluation activity in FY 2001. BMDO completed a feasibility study to move some or all of THAAD testing from Kwajalein Missile Range to the Pacific Missile Range Facility (PMRF) in Kauai, Hawaii. Based on the study, BMDO directed that PMRF would be the preferred alternative flight test range, pending environmental determination; Kwajalein may be used for the longer-range flight tests that cannot be conducted at PMRF.

## **TEST & EVALUATION ASSESSMENT**

THAAD PDRR testing was plagued with failures. These failures derived from an urgency to develop and deploy a prototype THAAD capability, the User Operational Evaluation System (UOES). This urgency drove the program to adopt an overly optimistic development schedule. This in turn contributed to deficient product assurance and inadequate ground testing. Quality control deficiencies in manufacturing the interceptor were a major factor in all but one of the flight test failures. Also, the integration of hit-to-kill technologies proved more difficult than anticipated. Pressures to field a TBMD capability quickly, coupled with program instability due to budget cuts and the freedom and flexibility allowed by acquisition reform, led to program decisions that resulted test failures that delayed the program several years. The Welch Panel in their 1998 Report concluded that the THAAD PDRR program “rushed to failure” because the program was schedule-driven.

The THAAD program has made significant progress since then by achieving two hit-to-kill intercepts with high accuracy. The intercepts demonstrated limited integrated system performance among the missile, launcher, radar, and BMC<sup>3</sup>I segments using scripted scenarios. DOT&E supported the decision to terminate testing on the PDRR missile and focus efforts on developing and testing the new EMD missile design that is intended to improve the performance, reliability, testability, producibility, and affordability of the missile.

DOT&E's proposal for early flight-testing with the new, "next-generation" missile has been integrated into the THAAD program schedule – first at White Sands, then at Kwajalein. The early flight-testing is designed to demonstrate the capability of the new missile design to reliably and accurately intercept "threat representative" ballistic missile targets. Five successful intercepts are planned prior to the Department's proceeding with the second limited production buy of the new missile design. The five intercepts will also provide critical data needed to validate the missile fly-out simulation for the redesigned missile. This approach provides an incentive for the contractor and Project Manager to conduct the necessary ground testing to achieve the five intercepts with the minimum number of flight test attempts.

The THAAD program should carry out ground and HWIL testing of the THAAD system, including system end-to-end testing. To support the system end-to-end testing, the THAAD program must incorporate a disciplined modeling and simulation approach for verification, validation, and accreditation and use element and system-level model and simulation extensively to ensure that adequate data are generated to support integrated test and evaluation.

This Page Is Intentionally Left Blank

## **DEFENSE JOINT ACCOUNTING SYSTEM (DJAS)**



The Defense Joint Accounting System (DJAS) is based upon the Army Corps of Engineers Financial Management System (CEFMS) that has been modified and upgraded to ease the transition from legacy systems to a single source, data entry transaction-driven U.S. Standard General Ledger environment. DJAS has been designed to provide a Chief Financial Officers Act (of 1990) capable accounting system that satisfies the Federal Financial Management Requirements and more importantly provides managers and users with timely, relevant, and accurate information for decision-making.

DJAS supports specific Army posts, camps, and stations; Army Materiel Command; and Defense agencies serviced by the DFAS-Indianapolis (DFAS-IN) Center. Contrary to what its name implies, DJAS does not support the Navy/Marine Corps or Air Force accounting requirements. DJAS does provide for a wide range of accounting and financial management functions to include (but limited to) funds control, general ledger, accounts receivable, accounts payable, cost management, and reporting. DJAS is a client-server system designed to run on mid-tier computers located at the Defense Information Systems Agency (DISA)-managed computing facilities or local automation offices (in areas not supported by DISA) with user access through the personal computer (PC)-based local area networks.

### **BACKGROUND INFORMATION**

DFAS was established in 1991, and was charged to develop a single corporate strategy to support all DoD finance and accounting functions. In 1996, the Under Secretary of Defense (Comptroller) directed the acquisition of a general funds accounting migratory system for specific Army and Defense agency customers serviced by the DFAS-IN Center. This was part of the DFAS migration strategy for general funds and working capital funds accounting systems as outlined in the "DFAS Accounting Systems Strategic Plan," released in 1997. The analysis of alternatives concluded that a re-engineered CEFMS best addressed the mission needs and customer requirements. The DJAS program has upgraded and modernized the CEFMS baseline application capability to accommodate customer requirements. The DJAS program acquisition strategy calls for incremental prototype testing for its customers. The Ballistic Missile Defense Office in Arlington, VA is the initial DJAS prototype site.

The IOT&E of DJAS, designed to evaluate the initial capability developed for Defense agencies, began in late May 2000. However, during testimony before the Government Reform Subcommittee, the DoD Inspector General criticized the Navy and Air Force for implementing their own migratory accounting systems, while leaving the Army as the only Service committed to DJAS. This criticism

resulted in the House Appropriations Committee Report recommending a FY01 funding reduction to each of the Services and DoD-wide accounts in the Operations and Maintenance Account under the title “DJAS.” This report further recommended terminating the DJAS program, citing Clinger-Cohen Act compliance concerns. (Termination was not ultimately directed.) The PMO, with the concurrence of Joint Interoperability Test Command (JITC), the designated OTA, suspended the IOT&E.

The National Defense Authorization Act for FY01 reported that DJAS is not prohibited (terminated). However, the Secretary of Defense may not make a Milestone III decision until a report is submitted to the Committee on Armed Services of the Senate and the Committee on Armed Services of the House of Representatives, addressing a number of programmatic issues such as a single DoD-wide general funds accounting system.

The Congress recommended in the National Defense Appropriations Bill for FY02 that the DJAS program be terminated, unless the Under Secretary of Defense (Comptroller) determines that DJAS is an essential part of the Department's Financial Management Modernization Strategy.

### **TEST & EVALUATION ACTIVITY**

Pending Under Secretary of Defense (Comptroller) determination of the role DJAS will play in the Department's Financial Management Modernization Strategy, all OT&E activities have been suspended indefinitely.

DJAS continues as the operational system for the Ballistic Missile Defense Organization and Fort Benning prototype locations. Developmental testing on system changes required to support the currently operational user base will continue as needed in FY02.

### **TEST & EVALUATION ASSESSMENT**

Developmental testing for maintenance releases continued throughout FY01. The Program Manager continues to refine the DJAS software to meet its users' needs. The assessment of DJAS will be completed upon the resumption and completion of IOT&E.

## **DEFENSE PROCUREMENT PAYMENT SYSTEM (DPPS)**

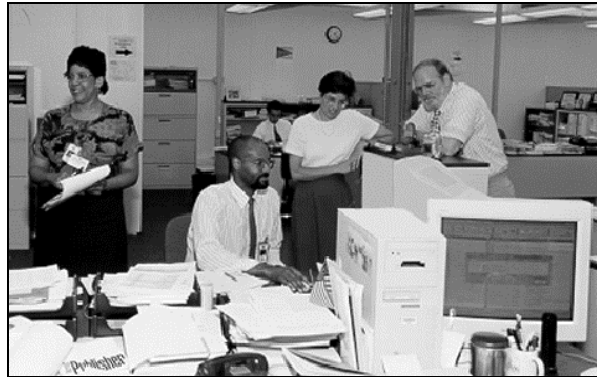

The Defense Procurement Payment System (DPPS) is planned to be the standard DoD procurement payment system used to calculate contract and vendor payments, grants, and other agreement entitlements. All DoD contract and vendor payment legacy systems will be consolidated into DPPS.

DPPS supports DoD contract and vendor entitlement functions through commercially derived applications software designed to operate in an open systems environment. DPPS will be implemented on Oracle Financials with four tiers. Tier One is a thin-client component acting primarily as the presentation layer. Tier Two is a web server supporting navigation via the web and workload balancing. Tier Three is an application server containing bulk of the application logic. Tier Four is a data base server. DPPS will use the Defense Financing and Accounting Service Enterprise Local Area Network. End-user hardware must be compliant with DFAS standards, which are consistent with the Defense Information Infrastructure Common Operating Environment.

### **BACKGROUND INFORMATION**

The current contract and vendor payment environment is comprised of many legacy systems that were not designed to share data or manage information from the DoD corporate perspective. Inefficiencies inherent in the operation of many semi-independent efforts have increased costs, caused major resource issues, unmatched disbursements, and focused attention on erroneous contract payments. The DPPS program was chartered to correct these and other shortcomings in procurement payment systems in 1995 and the Mission Needs Statement was approved in the same year. The DoD Comptroller reaffirmed the Mission Needs Statement in February 1997. The Operational Requirements Document, which was initially approved by DFAS in December 1997, has been updated in conjunction with the TEMP. Both documents are in staffing.

### **TEST & EVALUATION ACTIVITY**

During FY01, the PM conducted several phases of developmental testing with the intent to refine user requirements and to improve the software that is under development. Several Integrated Product Team meetings were held and a draft TEMP is currently in staffing.

## **TEST & EVALUATION ASSESSMENT**

The developmental test results showed that the initial DPS baseline solution met a significant amount of the DPPS requirements. Full compliance with the Critical Technical Parameters, however, could not be ascertained until additional end-to-end developmental testing is completed. No operational testing is expected until FY03. The Operational Test Division of the Joint Interoperability Test Command will conduct the operational testing of DPPS. A comprehensive test and evaluation assessment of DPPS will be completed after the completion of OT&E in FY03.



## **DEFENSE MESSAGE SYSTEM (DMS)**



The Defense Message System (DMS) is designed to enable anyone in DoD to exchange messages with anyone else in DoD using a secure, accountable, and reliable writer-to-reader messaging system. DMS supports organizational and individual messaging, handling both unclassified and classified traffic. DMS is intended to reduce the cost and manpower demands of the legacy organizational messaging system based on 1960s technology—the Automatic Digital Network (AUTODIN). To replace AUTODIN, DMS must be implemented in more than 40,000 organizations at more than 700 sites worldwide and must support message exchanges with tactical forces, allies, other Federal Government users, and defense contractors. The DMS program will ensure innovation by employing the latest commercial technology, supporting Allied Communications Publications (ACP) 120, and operating on Defense Information Infrastructure computers and communications backbone. While today's security needs require using the international X.400 messaging standard and X.500 directory services standard, the DMS program expects to eventually move to the use of commercial Internet e-mail standards once they evolve to adequately support security and military features. The timeline for such evolution is unclear at this time, but is a number of years in the future.

### **BACKGROUND INFORMATION**

The Defense Information Systems Agency began the DMS program in 1988. Since the 1997 IOT&E of release 1.0, DMS has continued to improve through OAs in 1998 and 1999, and an OT&E of release 2.1. The AUTODIN backbone has been downsized to three message-switching centers called DMS Transition Hubs (DTHs). An OA, conducted late October through early November 2000, found release 2.2 to be not effective and not suitable. The 2.2 OA revealed several system deficiencies, as well as numerous problems with site installations, configurations, and overall security posture of the system. DOT&E directed that DMS 2.2 be retested after the deficiencies were rectified.

### **TEST & EVALUATION ACTIVITY**

A Limited Field Test (LFT) of DMS 2.2 was conducted from March 26 through April 3, 2001 to reassess system effectiveness problems identified during the earlier OA. The LFT did not address operational suitability. Subsequently, DMS 3.0 underwent an OA in November 2001, and is now scheduled for a full OT&E late spring 2002. This OT&E will determine operational effectiveness and

suitability for sensitive compartmented information enclaves as well as unclassified and secret traffic. It will also have users performing more realistic mission essential tasks in a scenario-like environment.

## **TEST & EVALUATION ASSESSMENT**

DMS 2.2 performed significantly better in the LFT than in the earlier OA, and it was concluded that DMS 2.2 is operationally effective but not suitable. Administering DMS requires attention to detail and relies heavily on complex documentation and manual processes. Security tests revealed that system administrators had failed to protect all elements. A typical system administrator was poorly equipped to install, maintain, troubleshoot, and ensure security configuration of the system. In spite of these deficiencies, release 2.2 did not pose sufficient risk at this point in DMS maturation to preclude its operational use. However, the PMO must continue to streamline system operations, improve training, and enhance documentation. The system administrators must strictly follow all established security policies and procedures.

Although many measures of effectiveness were successfully met, the OA of DMS 3.0 showed that the system was not sufficiently mature for a full OT&E. Significant improvement was noted in the security posture, based on a limited security assessment. Interfacing to the legacy AUTODIN system was problematic, and especially so within the intelligence community. There were also problems with certificates and Fortezza cards within the Certificate Management Infrastructure.

## **LESSONS LEARNED**

The diversity of site configurations and operational needs poses design and testing challenges. Focus on security training and greater attention to detail during site installation and configuration is necessary and can lead to a relatively secure system. Installing and maintaining DMS is complex, and automated tools for assessing the system security configuration would be helpful. Operational tests have not focused on automated tools because they were under development. We recommend development focus on simplifying and supporting system administrator tasks followed by OT&E events exercising these critical support tasks, tools, and procedures. To achieve DTH closure by September 2003, the intelligence community will need a concerted effort to mature their implementation of DMS with particular focus on their Multi-Function Interpreter and Decision Agent products. Occasionally, DMS messages do not get delivered. In most of these situations, there is some type of system notification to either the sender or to a system administrator. Operational testing needs more focus on how message writers ultimately ensure the messages are received by the intended readers.

## BUSINESS SYSTEMS MODERNIZATION (BSM)



The Business Systems Modernization (BSM) is an across-the-board improvement and upgrade program for Defense Logistics Agency (DLA) operations. Central to the objective of the BSM program is the evolution of DLA's business practices to emulate best current commercial practices and the transformation of DLA from a manager of inventory to a broker of information. DLA is a logistics combat support agency responsible for providing supplies and services to America's military forces. DLA's missions include the management of over 4 million consumable items and the processing of more than 30 million annual distribution actions around the clock in all 50 states and 27 countries at over 500 sites worldwide.

BSM will consist of commercial-off-the-shelf (COTS) software running on existing hardware to support DLA processes. Since COTS products will only meet a portion of the BSM requirements, the use of bolt-on products and business process re-engineering are anticipated. BSM, when completely fielded, will allow DLA employees to accomplish the DLA missions more efficiently and effectively. The modernized business environment supports power projection through flexible logistics support. Small, agile fighting units will be provided with rapid, precise, and reliable delivery of supplies to an area of operation.

### **BACKGROUND INFORMATION**

The BSM program was conceived in late 1998 to address the radical changes in the way DLA does business and to overcome severe deficiencies in existing information support systems. As DLA strives to align business practices with best commercial practices by re-engineering logistics processes at all echelons, a robust technology is needed to support this re-engineering. Specifically, the BSM program is designed to establish a framework for continuous business practice improvements by:

- Shifting to commercial business practices and capitalizing on industry-based integrated supply chain solutions,
- Moving from organic to commercial sector support when business and readiness factors dictate, and
- Exploiting DLA's leveraged buying capabilities and harnessing that power through value-added electronic shopping opportunities to enable customers to get the best prices and fastest delivery of products and services.

The primary objective of this initiative is the attainment of a modern business systems environment. The Joint Requirements Oversight Council-approved Operational Requirements Document identified the need for DLA to manage to specific outcomes, allow optimization within given levels of resource, and support a management focus on product and operating-cost reduction. These objectives represent DLA's approach to meeting the requirements of the DoD and DLA Strategic Plans. The BSM strategy's first focus is to replace DLA's primary legacy materiel management systems—the Standard Automated Materiel Management System and the Defense Integrated Subsistence Management System—with an expanded enterprise computing environment and COTS software packages that include Enterprise Resource Planning and Advanced Planning Systems. The BSM strategy, over the course of several years, will result in a new agency-wide computing architecture that will enable the DLA to reengineer its logistics processes to reflect best modern commercial business practices.

### **TEST & EVALUATION ACTIVITY**

The BSM contract was awarded in August 2000. DT began in October 2001 and is scheduled to conclude by May 2002. OT has not yet been conducted. DOT&E reviewed and approved a Milestone B TEMP in August 2001 and expects to review a Milestone C TEMP in February 2002. This TEMP will serve as the primary test and evaluation planning document in preparation for a Milestone C review expected in the 3rd quarter of 2002.

### **TEST & EVALUATION ASSESSMENT**

No assessment results are available yet. The Program Management Office (PMO) has demonstrated proper emphasis on T&E activities needed to support the BSM program. DOT&E will continue working with JITC, the designated OTA, and the PMO to refine BSM T&E planning as the program evolves.

## FUELS AUTOMATED SYSTEM (FAS)



The Fuels Automated System (FAS) is an integrated relational database system using an open systems architecture design. FAS will consist primarily of two levels – Base and Enterprise – that will collectively provide an automated, integrated, and responsive system for managing DoD fuels. The Base Level system provides transaction data at the fuel distribution terminal, whereas the Enterprise Level system will handle procurement, supply, and financial functions. The Base Level System consists of 400 commercial-off-the-shelf (COTS) microcomputer servers and 1,300 COTS microcomputer workstations deployed to 600 Military Services and Defense Logistics Agency locations. The Enterprise Level system will comprise ten COTS mid-tier servers and existing office automation at the Defense Energy Support Command headquarters, its regions, and field offices.

Designated as the Corporate Information Management initiative for the functional area of energy management, FAS will support DoD fuels management with commercially available application software and take advantage of proven commercial business practices established in the petroleum industry.

### **BACKGROUND INFORMATION**

The FAS program was initiated in FY96 to accommodate evolving requirements for the fuels mission of the Defense Logistics Agency. FAS will increase fuel accountability at the Defense Fuel Supply Points, integrate automatic tank gauging and automated leak detection capabilities, provide a mechanism for specialized customer support through tailored terminal interfaces, and promote real-time data processing.

Since the completion of the Base Level system in FY97, the FAS PMO has turned its attention to the Enterprise Level system. The Enterprise Level system comprises two increments. The Oracle Federal Financials will provide accounts payable, general ledger, and accounts receivable functions. Oracle Energy Downstream, a COTS package that Oracle acquired from British Petroleum, will handle fuels purchases. Together, the two increments will provide a complete solution for budgetary accounting.

During an In-Process Review in August 1997, the FAS PM declared a schedule breach because of late software product deliverables from Oracle. The PM re-baselined the program. Throughout FY98 and FY99, implementation of the Enterprise Level System was delayed because the vendor failed to incorporate all requirements for prompt payment and price escalation into the Government layer of the

financial applications. During FY00 and FY01, the FAS PMO implemented changes in the FAS software, established information transfer capability between all FAS users, conducted FAS DT, and provided training to FAS users.

### **TEST & EVALUATION ACTIVITY**

Joint Interoperability Test Command (JITC), the designated OTA, conducted the IOT&E of the FAS system (Base and Enterprise levels combined) in August/September 2001. The testing was conducted primarily in the Rocky Mountain/West Coast Region. During the IOT&E, FAS was operating in parallel with the legacy system, Defense Fuels Automated Management System (DFAMS). DFAMS was the system of record during the test.

### **TEST & EVALUATION ASSESSMENT**

The IOT&E results showed that FAS was operationally suitable but not operationally effective. This conclusion was based on the fact that Critical Operation Issue (COI) Mission Performance, and COI Interoperability were not satisfactorily met during the IOT&E. DOT&E directed that a follow-on OA be conducted to re-evaluate the deficient areas after they are rectified. JITC conducted the follow-on OA in December 2001. The OA results showed that most of the problems have been either fixed or improved upon, with the exception of the problems associated with system access and audit log capabilities. The workarounds implemented during the OA were meeting the users' needs and most users interviewed indicated they were satisfied with the progress made.

FAS is continuing to move towards critical programmatic decisions, including addressing the October 12, 2001 memorandum from the OSD Comptroller concerning the Defense Financial Management Modernization Program and the Milestone IIIB deployment.

## STANDARD PROCUREMENT SYSTEM (SPS)



The Standard Procurement System (SPS) is designed to improve the speed and effectiveness of contract placement and contract administration functions. It will interact more effectively with other DoD activities and with industry, and improve visibility of contract deliverables while maintaining DoD readiness with reduced resources. SPS will comprise components at multiple levels, including mainframe processing at Defense Information Systems Agency MegaCenters, minicomputers at the intermediate level, and Local Area Network-based workstations at the user level. Software will consist of selected operating systems, network operating systems, client-server software, distributed systems software, and American Management Systems' commercial derivative software.

### **BACKGROUND INFORMATION**

The SPS acquisition strategy is based on procuring and enhancing American Management Systems' "Procurement Desktop-Defense (PD<sup>2</sup>)" software. To be delivered in four increments, SPS Increments 1 and 2 were operationally tested in 1997 and fielded to limited Defense Logistics Agency and Navy sites.

During the summer of 1998, Joint Interoperability Test Command (the designated OTA), conducted tests at two Army sites and two Navy sites on a portion of the Increment 3 software functionality. Based on the user-validated requirements in the ORD, JITC found that Increment 3 software was operationally effective and suitable for only a small number of contracting offices that had no or minimal prior automated procurement support. Due to the significant number of system deficiencies and inaccuracies, DOT&E determined that Increment 3 software was neither operationally effective nor operationally suitable for administering large procurement contracts. DOT&E recommended that the PMO take immediate actions to correct these deficiencies prior to full fielding.

Since the completion of Increment 3 OT&E, testing activities have been focused on conducting OAs on Increment 3 follow-on releases to verify correction of deficiencies and to assess enhanced capabilities. In March 1999, JITC conducted an OA at the Defense Information Technology Contracting Office (DITCO), Scott AFB, IL, on an Increment 3 follow-on release (Version 4.1) to verify correction of known system deficiencies and identify any improvements or degradation of system capabilities relative to earlier versions. Results of the OA were mixed: while there were still many unresolved system deficiencies of major operational impact, users noted that system functionality had improved in

comparison with the previous versions. Improvements were also noted in the user manuals, user interfaces, and system response times.

### **TEST & EVALUATION ACTIVITY**

Throughout FY00 and FY01, JITC has continued to conduct OAs for the SPS Increment 3 follow-on releases to provide feedback to the PMO to improve SPS performance. JITC uses sites that had already converted over to SPS from their legacy systems. To date, JITC has conducted OAs at 28 sites of all military Services, with the participation of over 300 users. Software acceptance testing of Version 4.2 is currently planned to complete prior to the end of 2001. Prior to fielding, Defense Contract Management Agency will conduct pilot tests with concurrent OAs conducted by JITC in the January-March 2002 timeframe.

A full OT&E is planned for SPS Increment 4 (Version 5.0)—the full operational capability system—in late FY02. This increment is intended to provide full functionality to support major weapons system contracts, including all external system interfaces and Internet-based electronic commerce/electronic data interchange capabilities.

### **TEST & EVALUATION ASSESSMENT**

As knowledge and experience with the SPS application software increase, users believe that they will be better able to use SPS to support their contracting activities. They also stated that SPS holds much potential in their operational environments as the system matures. However, based on OA findings, a variety of issues remain; some span many sites and some are site-unique. In general, users expressed a desire for longstanding deficiencies to be corrected as soon as possible. The SPS PMO must continue to focus on correcting deficiencies identified during the previous tests. To ensure that the full OT&E of Increment 4 truly tests the capability of SPS in supporting the operational missions of DoD procurement offices, robust developmental testing and system acceptance testing must be completed first. Furthermore, the user communities and SPS PMO must support JITC's efforts fully in developing a sound and comprehensive operational test plan for SPS Increment 4.



## **JOINT BIOLOGICAL POINT DETECTION SYSTEM (JBPDS)**



The primary purpose of the Joint Biological Point Detection System (JBPDS) is to limit the effects of biological agent attacks that have the potential for catastrophic effects on U.S. forces at the operational level of war. The JBPDS is intended to provide biological agent point-detection, identification, and sampling capability for both fixed-site and mobile operations. The system is intended to detect biological agents in less than one minute and identify the agents in less than 15 minutes. The Block I version, scheduled for fielding during FY03, is intended to identify ten agents. The follow-on Block II version, scheduled for fielding during FY07, will integrate advances in technologies to decrease size, weight, and power requirements, as well as to identify 26 agents. Both block versions are intended to interface with the Joint Warning and Reporting Network (JWARN).

The capabilities of JBPDS will be used by each of the Services. The Army's JBPDS platform, shown above, is the S788 lightweight multi-purpose shelter mounted on a High Mobility Multipurpose Wheeled Vehicle (HMMWV) - Heavy Variant. The Marine Corps will deploy a stand-alone man-portable JBPDS configuration for employment by foot-mobile reconnaissance units. The shelter-mounted unit will also be integrated as a biological component suite installed on both HMMWV based and Light Armored Vehicle (LAV) based Joint Services Light NBC Reconnaissance Systems (JSLNBCRS). The Marine Corps is the lead Service for development of the JSLNBCRS.

The Navy's JBPDS will be installed on deployable surface ships and at high priority shore installations worldwide, while the Air Force will deploy the fixed-site, man-portable, and shelter-mounted JBPDS units for air base protection.

### **BACKGROUND INFORMATION**

In June 1995, the Program Manager, Joint Program Office for Biological Defense approved the Milestone 0 transition of the JBPDS into the Concept Definition Phase for Block I. A Milestone I decision in June 1996 formalized and established JBPDS as an Acquisition Category (ACAT) III Program. In December 1996, the Program Manger approved the Milestone II decision for JBPDS, and the system transitioned into the engineering and manufacturing development phase. JBPDS was placed under DOT&E oversight in January 2000. In August 2000, JBPDS was re-designated an ACAT II program.

The Army is the lead materiel developer and developmental tester and evaluator for JBPDS, while the Air Force is the lead operational tester and evaluator.

In October and November 1999, AFOTEC conducted an Operational Utility Evaluation (OUE) of the JBPDS. The OUE was conducted during field trials sponsored by the Joint Program Manager. These trials were primarily designed to compare different trigger/detector technologies in side-by-side testing. The OUE also allowed AFOTEC to make an initial evaluation of the military effectiveness and suitability of JBPDS based upon observations and data collected during the test period.

In conjunction with MCOTEA and OPTEVFOR, AFOTEC conducted an OA in May-June 2000 of the man-portable, fixed-site, and shipboard versions of the JBPDS in support of a low-rate initial production decision. ATEC simultaneously conducted a Limited User Test (LUT) of the HMMWV-mounted version of the system. The shipboard version of the JBPDS was tested on the USS Comstock, while the other versions were tested at Dugway Proving Ground. The Dugway testing was conducted in conjunction with JBPDS Pre-Production Qualification Testing. The DOTE approved the OA/LUT Plan on May 15, 2000.

AFOTEC and ATEC evaluated the military effectiveness and suitability of JBPDS in a semi-operational field setting. JBPDS units were subjected to aerosol challenges using benign biological agent simulants and typical battlefield interferents. Sophisticated instrumentation was required to determine if and when the systems were exposed to the simulated contamination.

Military and civilian operators set up, replenished, monitored, and transported these units during the field trial events. The adequacy of the training program to support JBPDS deployment was evaluated, and RAM data were collected throughout the test effort. Fourteen JBPDS systems were evaluated during this testing: four HMMWV-mounted, four fixed-site, five man-portable, and one shipboard.

In addition to the field testing of JBPDS with biological agent simulants, Dugway Proving Ground personnel conducted live biological agent testing of the system inside a specially sealed biohazard-safe chamber.

Data and insights gained from the OA, LUT, and the live agent testing were used to support the Joint Program Manager for Biological Defense two-phase LRIP decision on October 2, 2000. Under this plan, during the first LRIP phase, nine systems were built for First Article Testing (FAT) and a second operational assessment (OA2).

## **TEST & EVALUATION ACTIVITY**

OA2 was conducted in late September and early October 2001. After FAT and OA2 are completed, the Service Operational Test Agencies will advise the Joint Program Manager if the system meets specific criteria addressing detection, identification, and system reliability. The Joint Program Manager will then decide in late November 2001 if the system can proceed to the second LRIP phase. During this phase, up to 16 additional systems will be constructed for an IOTE scheduled to be conducted in late FY02.

DoD Regulations state that a TEMP must be submitted to OSD within 90 days after being placed on oversight. However, because the program was involved in planning, executing, and evaluating

operational assessments when the program was placed on oversight, DOTE has extended the deadline for TEMP submittal to the end of CY01. The TEMP is currently under revision.

## **TEST & EVALUATION ASSESSMENT**

The results of the OUE, OA, LUT, and live agent testing are still emerging. Early live agent test results indicate that JBPDS shows substantial promise for detecting biological agents in a sealed chamber under closely controlled environmental conditions. However, field test results of JBPDS variants have not demonstrated that these systems meet the requirement that they must detect biological agents at least as well as currently fielded interim systems. (The exact requirement is classified.) During field testing, the systems experienced a large number of false detections; i.e., the systems indicated the presence of biological agents when no agents were known to be present.

Given that a detection has occurred, JBPDS must have a probability of 98 percent or better of correctly identifying the detected agent within 15 minutes. Preliminary indications are that the JBPDS did not meet this requirement for all simulants under field conditions.

The system fell well short of the requirement for Mean Time Between Operational Mission Failures of 144 hours. The estimate of reliability for the fixed site configuration is 43 hours, for the man-portable configuration 70 hours, and for the shelter configuration 92 hours. Numerous hardware and software deficiencies were encountered.

The systems demonstrated significant human factors deficiencies. Operators in protective gear experienced difficulties, particularly in assembling and disassembling the system. The set-up time for the man-portable units often exceeded requirements. The systems have numerous sharp edges that can injure users and puncture protective gear. The man-portable units are so heavy that the four-man crews experienced difficulties in transporting them. Generator exhaust hose leaks can allow generator exhaust to seep into the closed JBPDS shelter, which is a safety issue that must be resolved.

DOT&E requires an end-to-end test to demonstrate that the JBPDS can collect, detect, identify, and package a live biological warfare agent sample adequate for laboratory testing. This test must also include the capability of the supporting force to transport the sample to a rear-area laboratory where the identity of the BW agent can be confirmed. To date, no facility has been identified that is large enough to accommodate collection, detection, and identification testing on an entire JBPDS unit.

The Program Office has proposed that live agent testing performed on key JBPDS subsystems can meet this requirement; however, DOTE and the Service operational test agencies are skeptical of this approach as adequate for operational test purposes. The Service OTAs are working with Dugway Proving Ground to either locate a private facility that can accommodate such testing, or identify potential workarounds that can be implemented at the Dugway live agent test facility.

## **CONCLUSIONS**

The JBPDS Program Office has studied the results of the OA and the LUT, and is implementing an aggressive program to correct the deficiencies observed during this testing. Modifications of the system variants include an enhanced capability for detecting and identifying biological agents under field conditions, reduction of false detections, improved system reliability and software performance, and correction of demonstrated human factors deficiencies.

The lack of hardware maturity evidenced during the OUE/OA/LUT puts the Program Manager's ambitious schedule in jeopardy. However, this risk is at least partially mitigated through the two-phase LRIP approach and the provision for a second Operational Assessment prior to the Initial Operational Test.

## JOINT CHEMICAL AGENT DETECTOR (JCAD)



The Joint Chemical Agent Detector (JCAD) is a pocket-sized device that is intended to automatically detect, identify, quantify, and warn users of the presence of nerve, blister, and blood chemical agents. JCAD will be mounted on a vehicle, tripod, aircraft, or ship, or fastened to the operator's load bearing equipment. The system is intended to be capable of being operated as a stand-alone detector; as part of a small local network of other JCAD units; or interface with the Joint Warning and Reporting Network (JWARN), as part of a larger network of biological and chemical detectors.

JCAD's hardware consists of the main Detector Unit (DU); a pre-concentrator accessory for extending the lower detection limit of the DU; and an interface cradle that includes a mount and connections to interface the DU with external power, external alarms, and other DUs to form a local detection network. One detector configuration is planned for use by all of the Services. JCAD will replace or augment existing Service-unique chemical agent detectors.

### **BACKGROUND INFORMATION**

A combined Milestone I/II decision was made in December 1997 that allowed JCAD to enter into Engineering and Manufacturing Development (EMD). Phase I of the EMD contract was awarded in February 1998, and the Phase II contact option was exercised in April 1999. JCAD was placed under DOT&E oversight in January 2000.

The Air Force is JCAD's lead materiel developer, while the Army is the lead developmental and operational evaluator.

The Program Director of the U.S. Air Force Human Systems Program Office approved the Milestone I/II TEMP on September 10, 1997.

During the period January-March 2000, the government conducted Phase I Engineering Design Testing (EDT) of a brass board hardware and software prototype JCAD. The purpose of this testing was to provide an early assessment of the critical detection, identification, and quantification sub-systems prior to critical design review. This testing, which involved challenging the device with actual chemical agents, chemical agent simulants, and common battlefield interferences, was specifically designed to reduce the government's risk prior to finalizing the design of the device.

## **TEST & EVALUATION ACTIVITY**

The program has breached its acquisition program baseline due to cost, schedule, and performance problems. The TEMP is under revision to reflect these baseline changes.

Live agent testing of an improved Phase II prototype was conducted at Dugway Proving Ground during the summer and fall of 2001. This testing was designed to demonstrate that the Phase II prototype meets all of the chemical agent detection, classification, and quantification requirements of the performance specifications. The results of this test are not yet available.

## **TEST & EVALUATION ASSESSMENT**

Although limited in scope, the results of the engineering development test indicated that the Phase I JCAD prototype was not ready to proceed beyond the critical design review. The Phase I prototype baseline technology demonstrated the capability to detect only seven out of the required ten chemical agents. The sensor algorithm required significant improvement to reliably detect chemical agents at the concentration levels specified in the JCAD Joint Operational Requirements Document (JORD). In addition, the device needed to display an enhanced capability to reject false positive alarms.

Results of the Dugway live agent testing of the Phase II prototype will be reviewed during a special design review in early CY02.

## **JOINT SERVICES LIGHT NUCLEAR, BIOLOGICAL, AND CHEMICAL RECONNAISSANCE SYSTEM (JSLNBCRS)**

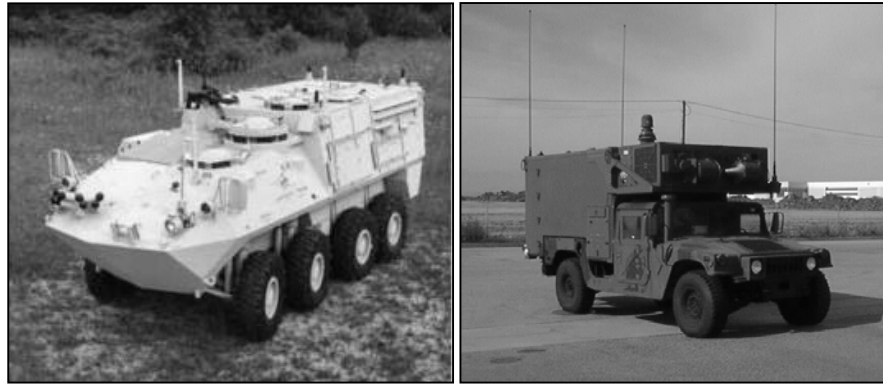

The Joint Services Light Nuclear, Biological and Chemical Reconnaissance System (JSLNBCRS) is a specialized, mobile reconnaissance system intended to detect and report NBC hazards on the battlefield. The JSLNBCRS consists of a Base Vehicle equipped with hand-held and vehicle-mounted NBC detection and identification equipment. Detectors selected for use on the JSLNBCRS provide the capability to sample, detect, and identify known NBC agents as well as Toxic Industrial Materials (TIMs). Communications equipment is required to transmit analog and digital messages and NBC contamination warnings. A system for marking contaminated areas is also included. Local meteorological and accurate navigation information is provided by onboard meteorological and global positioning systems. Two base vehicles are planned: the High Mobility Multipurpose Wheeled Vehicle (HMMWV) for the Army, Air Force, and Marine Corps, and the Light Armored Vehicle (LAV) for the Marine Corps.

JSLNBCRS will provide new sensors and information dissemination systems to detect chemical or biological attack at extended ranges and provide warning to affected units. JSLNBCRS will be employed in forward combat areas and integrated into the overall reconnaissance and surveillance effort to support combat operations. It will also be employed in rear areas to monitor main supply routes, logistics bases, airfields, ports, and key command and control centers for NBC hazards.

### **BACKGROUND INFORMATION**

On June 26, 2001, the Milestone Decision Authority (MDA), Commander, Marine Corps Systems Command, approved JSLNBCRS's entry into System Development and Demonstration (SSD). A Milestone C for the HMMWV variant is currently scheduled for the 4QFY02. A Low-Rate Initial Production (LRIP) is planned for 14 HMMWV systems to be used in production qualification testing, logistics demonstrations, interoperability/information assurance testing, reliability and maintainability testing, and for IOT&E. The Program Manager is considering production options, which may change the configuration of the vehicle. The MDA established the following Phase B exit criteria for the program:

- Successful developmental test and field user test.
- Establishment of a configuration baseline for the HMMWV and LAV variants. This will include documented agreement by all participating Services regarding the sensor, diagnostic, and communications suite that will be installed in the system as it enters production.
- Achievement of all Key Performance Parameters listed in the Joint Operational Requirements Document.

## **TEST & EVALUATION ACTIVITY**

The JSLNBCRS TEMP was approved by DOT&E on June 11, 2001.

DT II is planned for the HMMWV variant from February 2002 to May 2002. A Limited User Test (LUT) will follow DT II, which is intended to support the LRIP decision in October 2002. The HMMWV LUT will test the operational effectiveness and suitability of JSLNBCRS performing reconnaissance and security missions in a combined USMC-USA ground scenario and a combined USMC-USAF airbase scenario. A DT III of the LRIP units will follow the LUT to address operational issues found in testing before the IOT&E.

Two LAV vehicles, which have been refurbished, will be integrated with the common JSLNBCRS mission suite from July 2001 to October 2002. DT II for the LAV system is planned from January 2003 to October 2003 and precedes the IOT&E.

A common HMMWV-LAV IOT&E will repeat similar mission scenarios and test scope as the Limited User Test, with the addition of a USMC LAV amphibious reconnaissance and security scenario.

## **TEST & EVALUATION ASSESSMENT**

Since JSLNBCRS was placed under DOT&E oversight in January 2000, the Program Manager has worked diligently to address DOT&E concerns with the TEMP. Because of DOT&E's involvement with the revision process, the TEMP now does a credible job of identifying key decision points in the program, and tests required to support these decisions. Realistic scheduling is used throughout the program's strategy. For example, redesign and retest are built in after the Limited Use Test to respond to system problems discovered in the test. The test scope clearly addresses mission, tactical events, operational profiles, battlefield conditions, military operators, threat dissemination, command and control, and resources.

The most significant problem facing the JSLNBCRS program is the integration, performance, and stability of the NBC suite for IOT. JSLNBCRS, which is dependent on several key programs, including Joint Service Lightweight Standoff Chemical Agent Detector (JSLSCAD), Joint Biological Point Detection System (JBPDS), and Chemical Biological Mass Spectrometer (CBMS), will be challenged by the timing and performance of these independently managed systems. This risk explains the MDA's rationale for establishing a clear configuration baseline before operational testing and production. These dependencies will be closely monitored by DOT&E. The prospect of changing production configuration raises the issue that the system that will be tested in IOT&E might not be the system that is fielded. A Follow-On Test and Evaluation must be conducted for the full-rate production system.



In the past year the Commander, Army Chemical School, has developed a requirement to use the Interim Armored Vehicle as the platform for NBC reconnaissance. If implemented, this requirement would terminate Army participation in the JSLNBCRS program. Although this is not yet the Army position, it has the practical effect of hindering current planning for operational testing.

Among the six original chemical-biological systems placed under DOT&E oversight, the JSLNBCRS has the only DOT&E-approved TEMP. The JSLNBCRS TEMP is a model for other chemical-biological test programs. The JSLNBCRS program should have a successful test and evaluation if the TEMP is executed, and if JSLSCAD, JBPDS, and CBMS are mature enough and integrated to be tested as part of the system.

This Page Is Intentionally Left Blank

## JOINT SERVICES LIGHTWEIGHT STANDOFF CHEMICAL AGENT DETECTOR (JSLSCAD)

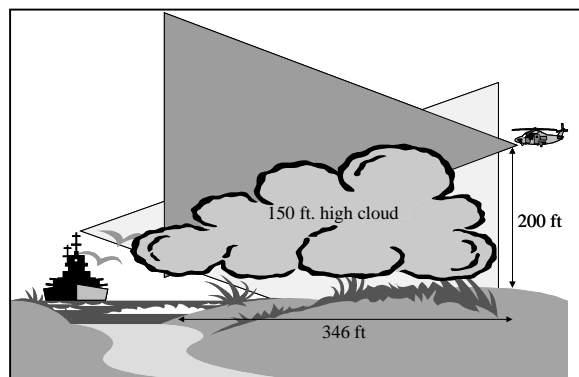

The Joint Services Lightweight Standoff Chemical Agent Detector (JSLSCAD) is a passive device intended to provide standoff detection of chemical agent vapors up to 5 km distant (with a 10 km objective). JSLSCAD is intended to provide real-time, on-the-move, chemical agent vapor detection for contamination avoidance and reconnaissance systems. JSLSCAD is intended to detect the chemical warfare threat to U.S. Forces as documented in the Capstone System Threat Report, "Chemical and Biological Warfare Defense Systems-Non Medical," dated November 1996.

This system will be installed in fixed locations for protection of facilities and installations such as air bases. The JSLSCAD is intended to provide visual and audible indicators, to display the chemical agent class (nerve, blister, and blood), and to indicate the location (azimuth and elevation) of the detection. Detection and warning information may be entered automatically into Service Command, Control, Communications, Computers and Intelligence (C4I) systems, or the information may be reviewed and distributed manually. JSLSCAD is to be interoperable with the Joint Warning and Reporting Network (JWARN), and thus will provide chemical agent vapor detection warning for a Joint Task Force commander or a theater command and control function.

The JSLSCAD consists of four major components: scanner module, sensor electronics module, operator display unit, and power adapter. There are two configurations of the scanner module. The aerial applications scanner covers a 60 degree forward looking cone, and the ground mobile/fixed site/shipboard configurations scan 360 degrees in azimuth and +50 to -10 degrees in elevation. The system is intended to be integrated into the Joint Service Light NBC Reconnaissance System (JSLNBCRS) and the Interim Armored Vehicle-Reconnaissance Vehicle (IAV-RV), and will be employed aboard Navy landing ship docks or equivalent aviation capable amphibious ships. JSLSCAD also will be carried on Army and Navy helicopters, and outboard on selected Air Force C-130 aircraft. Present plans call for the JSLSCAD to be carried as an unmanned aerial vehicle (UAV) payload, but the UAV to be used has not been selected.

### **BACKGROUND INFORMATION**

The current operational requirements document was approved in June 1997, and is now being revised. JSLSCAD achieved Milestone II on September 17, 1996. The TEMP for JSLSCAD was

approved in 1997, before the system came under DOT&E oversight in January 2000. A revised TEMP is being prepared.

### **TEST & EVALUATION ACTIVITY**

JSLSCAD's engineering development tests were completed in April 2001. In 2001, the Program Manager has conducted studies and test methodologies to support future developmental and operational testing. Field methodology tests to prove the ability to release chemical simulant clouds by threat representative explosive disseminations, and by non-representative hot stack dispersals, and to prove the ability to measure the subsequent size, concentration and movement of these clouds, was held at Dugway Proving Ground during October 2001.

### **TEST & EVALUATION ASSESSMENT**

Testing limitations include the use of simulants in Multi-service Operational Test and Evaluation (MOT&E) instead of live agent. These simulants approximate the spectral or physical characteristics of real agent, but do not entirely match actual agents. Other limitations include simulation of delivery of agent by use of explosive and line and stack release devices instead of actual weapons, and the use of a restricted C4I network warning capability instead of a full theater or Joint Task Force C4I system. Also, achieving ideal delivery conditions during testing is difficult because of the vagaries of weather, and the desired effects of the atmospheric mixing layer dictates that releases are best made during the night and early morning hours. The test site, Dugway Proving Ground, is itself a limitation in that it is an isolated, desert location that does not replicate military installations, urban areas, or many types of battlefields where JSLSCAD likely will be deployed. The Program Manager has developed test methodologies to mitigate these limitations. For example, a test methodology which entails live agent and simulant testing in a static chamber, but using simulants only to test detection ranges is being developed. Operational tests will be conducted under conditions representative of the expected employment environments with a representative friendly force and C4I network, but will be limited in that no live agent will be used (except in controlled chamber testing).

The test budget for Production Qualification Testing/Developmental Testing during FY 2002 is not fully funded. A total of \$7.3M is required; \$6.1M is funded, and the Joint Service Materiel Group has assured the Program Office that the remainder will be provided. Funding for the MOT&E in FY03 is uncertain. Recent additions to the test scheme involving extensive flying by helicopters and C-130 aircraft will add an as yet undetermined amount to the cost.

## JOINT WARNING AND REPORTING NETWORK (JWARN)

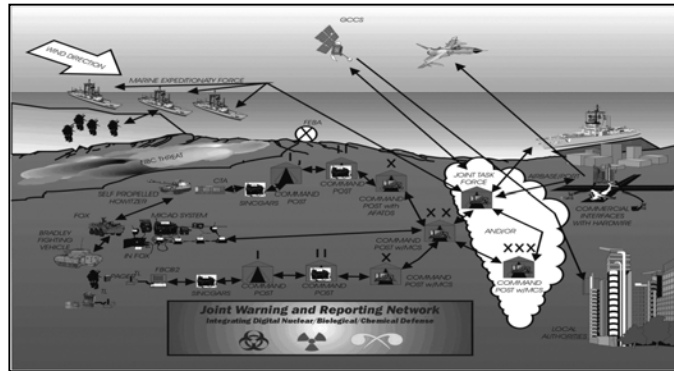

The Joint Warning and Reporting Network (JWARN) is a standardized software application intended to provide NBC warning and reporting, downwind hazard prediction, operations planning, and NBC management capabilities for Joint Forces, from battalion to theater-level command. JWARN will be located in the NBC Cell of Command and Control Centers and employed by NBC specialists and other designated personnel. In peacetime, JWARN will assist local commanders to assess and predict the effects of Toxic Industrial Materials (TIM) accidents. Its primary functions are summarized below:

### *Essential Wartime tasks*

- Report and warn Commanders and personnel of NBC attacks.
- Perform analysis of NBC information, and conduct hazard prediction, modeling, and simulation of NBC attacks.
- Support planning and assessments of NBC defense.

### *Peacetime tasks*

- Support assessments and predict effects of TIM accidents.

### *Supporting tasks*

- Support sensor management including maintenance planning, configuration control, performance monitoring, and testing.

JWARN will be hosted on Joint and Service Command, Control, Communications, Computers, Intelligence, Surveillance, and Reconnaissance (C4ISR) systems utilizing the Defense Information Infrastructure Common Operating Environment (DII COE) common resources applications. JWARN C4ISR host systems include: Global Command and Control System (GCCS), GCCS-Army, GCCS-Maritime, Maneuver Control System, the Theater Battle Management Core Systems, Force XXI Battle Command, Brigade and Below, Advanced Field Artillery Tactical Data System, and Command and Control PC. The JWARN will share information with Command and Control and other DoD data bases providing information on friendly and enemy forces, terrain, weather, and others.

This system is intended to exchange information with legacy and new development NBC sensors, including the M8A1 Chemical Agent Alarm, M21 Remote Sensing Chemical Agent Automatic Alarm, M22 Automated Chemical Agent Detection Alarm, Integrated Point Detection System, Radiac AN/VDR-

2, Radiac ADM-300A, and the following systems in development: Joint Biological Point Detection System, Joint Services Lightweight Standoff Chemical Agent Detector, Joint Chemical Agent Detector, NBC Reconnaissance System, and Joint Services Light NBC Reconnaissance Vehicle. The JWARN Component Interface Device will allow the exchange of information between the NBC sensors and the JWARN application hosted on the C4ISR systems via Service specific C4ISR communications architecture (radio, wire, etc).

The NBC information, consolidated by JWARN in conjunction with weather, friendly and enemy position location information, is intended to support the development of NBC warnings, contaminated area predictions, and overlays showing areas of actual contamination (NBC reports) supporting the near-real time warning and reporting of NBC attacks. This NBC information then becomes a part of the Commander's Situational Awareness-Critical Information Requirements, and Essential Element of Information supporting the decision-making process. JWARN is also intended to provide the capability to produce plans and reports and to access specific NBC information to improve the efficiency of limited NBC personnel assets.

## **BACKGROUND INFORMATION**

The Marine Corps is the lead Service for JWARN development, and the Commander, Marine Corps Systems Command is the Milestone Decision Authority (MDA).

The current program evolved from an earlier program called Block I JWARN. In FY97 the MDA approved the fielding of Block IA, which comprised the following collection of commercial and government off-the-shelf software: Hazard Prediction Assessment Capability, Vapor Liquid, Solid Tracking, and Emergency Information Management System. Since this initial fielding, JWARN functions have been successfully integrated with the Army's UNIX-based Maneuver Control System (Block IB), and with the Windows 98 and Windows NT operating environments for the USAF, USN, and USMC (Block IC). Blocks IA and IC have been fielded. Block IB was not fielded, but successfully demonstrated the compatibility of JWARN with the JTA.

In December 1997, the MDA approved a Program Definition and Risk Reduction (PDRR) phase for Block II development, the current program. Activities associated with this effort are still ongoing. During PDRR, a Performance Specification and the Interface Requirements Specification were completed as a prelude to a solicitation for Engineering and Manufacturing Development. Source selection was completed in FY00, but a contract was not awarded due to lack of proper a C4ISR technical approach. The MDA changed program management in June 2001, forming a partnership between the NBC division of Marine Corps Systems Command, and its C4I division, with the latter designated as lead. Since this change, and in light of program delays experienced since the program was placed under DOT&E oversight in January 2000, the C4I Program Manager has decided to re-baseline the system. The Acquisition Strategy, Acquisition Program Baseline Agreement, schedule, and TEMP are all under revision. A contract to perform JWARN system Integration and Demonstration will be re-competed based on the revised program, with a Milestone B now planned for 3QFY02.

## **TEST & EVALUATION ACTIVITY**

Following designation as a DOT&E oversight program on January 18, 2000, the USMC, as lead Service, has undertaken an extensive review of the JWARN TEMP.

The Acquisition Strategy and Integrated Test Program Summary are under review.

## **TEST & EVALUATION ASSESSMENT**

Since the program was placed on oversight, DOT&E has worked closely with the Marine Corps Systems Command to address the inadequacies of the TEMP.

JWARN is a complex system because it must integrate with so many joint C4ISR systems and NBC sensors. To date, Measures of Effectiveness and Performance have been exclusively technical, or focused on maintainability and environmental suitability. As a result, a significant degree of planning is necessary to bridge the gap between technical criteria and operational criteria for IOT&E, and to understand exactly what information is to be exchanged and by what systems. There also has been a tendency to view the performance of JWARN in isolation – first from the NBC sensors and, second, from the host C4ISR systems. It will be a challenge to conduct operational testing within the context of the total system of forces, sensors, and C4ISR systems.

Despite the significant development already demonstrated with Block I and the PDRR phase, there is no Block II Acquisition Strategy. The TEMP is not approved and must describe system content, development priorities, scope of planned testing, and resources adequately.

This Page Is Intentionally Left Blank



## COMPOSITE HEALTH CARE SYSTEM II (CHCS II)



The Composite Health Care System II (CHCS II) is a tri-Service, medical management automated information system (AIS) that will be used in all military treatment facilities (MTFs) worldwide—fixed, deployed, and aboard ships. The core capability is a uniform, comprehensive, legible, secure Computer-based Patient Record (CPR) for every beneficiary. CHCS II integrates the existing CHCS and the functions of over 40 different DoD and Service-unique systems in various stages of development, while also providing new capabilities. It integrates medical and dental information, and is a key enabler for Force Health Protection and Population Health Improvement, two cornerstones of military medicine. CHCS II also addresses the need for readily accessible health care information on deployed Service members.

### **BACKGROUND INFORMATION**

CHCS II will be implemented in multiple releases with increasing functionality. The system was awarded Milestone I in May 1998, and in 1999, ATEC, the independent OTA, conducted a Customer Test (a type of OA) on a CHCS II risk reduction phase system that was installed in three clinics in Hawaii. The results indicated that the prototype system was not operationally effective or suitable, but the assessment provided valuable information used to design the next iteration of the software, which incorporated substantial operational and technical architectural changes. In August 2000, ATEC conducted an abbreviated OA in Hawaii on an early version of CHCS II Release 1. Most of the users agreed that it was superior to the version tested the year before, but response times, reliability, and ease of use still did not meet user requirements. The PM used user feedback to continue to improve the software. In September 2000, the Joint Requirements Oversight Council approved a comprehensive CHCS II ORD.

### **TEST & EVALUATION ACTIVITY**

Release 1, which targets ambulatory care, has successfully completed laboratory DT&E. It is now installed in selected clinics at four test sites: Portsmouth Naval Medical Center, VA; Langley AFB, VA; Fort Eustis, VA; and Seymour-Johnson AFB, NC. Data collection for Government Installation Acceptance Test will begin in January 2002, when CHCS II will be evaluated in an operational environment, without artificial constraints. Formal IOT&E is scheduled to occur at these same test sites in June 2002.

## **TEST & EVALUATION ASSESSMENT**

CHCS II is very complex, and much coordination is required between the Services, the separate product managers of the many migration and legacy systems, and the test community. The PM has very effectively utilized Integrated Product Teams (IPTs), but funding fluctuations and architectural changes have presented challenges in planning for IOT&E of the integrated system. DOT&E actively participates in these IPTs to provide guidance.

Since it will be DoD's premier health care system, CHCS II will have a tremendous operational impact on the fighting force. The CPR will be the first (military or civilian) cradle-to-grave automated health care record: one that can revolutionize the effectiveness of the Military Health System (MHS) by providing instantaneous patient information to health care providers worldwide. An associated "smart card" will enable the warfighters to carry some of this information with them, thus enhancing combat effectiveness by expediting health care at all levels.

CHCS II is on the leading edge of technology and must link multiple commercial-off-the-shelf products in a way that is not being done or is even feasible in the civilian sector. It requires health care providers to become increasingly "computer literate" and also introduces new techniques and procedures, such as the use of templates to record patient encounters in an effort to standardize the CPR.

DOT&E will continue to actively support the IPT process and directly assist in test planning so that IOT&E can take place as soon as practicable. DOT&E's independent assessment will provide recommendations that should aid the DoD in fielding the best possible clinical system to support the MHS.

## **DEFENSE MEDICAL LOGISTICS STANDARD SUPPORT AUTOMATED INFORMATION SYSTEM (DMLSS AIS)**



The Defense Medical Logistics Standard Support (DMLSS) program defines and implements a more efficient medical logistics capability for military treatment facilities (MTFs) and field units to support health care operations. The DMLSS Automated Information System (DMLSS AIS) is intended to enhance operations by automating manual processes, improving processes already automated, and eliminating existing processes that add no value. It has replaced a number of legacy systems operated by the individual Services, with three remaining to be replaced by the final release. The system supports four major functional areas: (1) materiel management, (2) facility management, (3) equipment and technology, and (4) wholesale operations. The first three of these are retail medical logistic functions that are performed by MTFs and field units worldwide. The wholesale functions are performed at only one site—the Defense Supply Center, Philadelphia.

DMLSS AIS integrates the medical logistics systems of the Services, reduces MTF inventories of medical and pharmaceutical items, and decreases the medical logistics footprint. This integration decreases the vulnerability of logistics lines of communications to deployed forces.

### **BACKGROUND INFORMATION**

DMLSS AIS wholesale and retail systems were first deployed to test sites in 1995. Following successful OT&E of the wholesale system, OPTEVFOR, the independent OTA, determined that there was little risk in implementing future enhancements at the single wholesale location and DOT&E concurred. Over the years, OPTEVFOR has performed independent OT&E on two major releases and some incremental enhancements of the retail system. DMLSS AIS Release 2.0, which supports materiel management and facilities management functions, has been fielded worldwide to approximately 110 MTFs. Release 3.0, the final increment, will enhance the materiel management module and add a third module to support equipment maintenance and inventory, and the acquisition of new technology.

In January 2000, OPTEVFOR conducted OT on live DMLSS AIS 2.0 systems at three test sites: Fort Knox, KY; Great Lakes Naval Training Center, IL; and Yokota Air Base, Japan. DOT&E's independent assessment concluded that DMLSS AIS 2.0 was operationally effective and operationally suitable. Subsequently, in June 2000, OPTEVFOR performed OT&E on Customer Support on the Web (CSW), an enhancement that enables customers to receive medical logistics support by accessing web-

based applications. DOT&E concluded that CSW was operationally effective and suitable. DOT&E recommended that both DMLSS AIS 2.0 and the CSW enhancement be deployed worldwide.

### **TEST & EVALUATION ACTIVITY**

DMLSS AIS 3.0 is currently completing DT&E at three MTFs in the United States. The software has been or is being installed at three additional test sites where OT&E is scheduled for 2QFY02: Naval Medical Center, Portsmouth, VA; David Grant Medical Center, Travis AFB, CA; and Brooke Army Medical Center, Fort Sam Houston, TX. As with previous releases, the general OT concept will be to: (1) observe users performing typical actions in an operational environment; (2) distribute user questionnaires and conduct user interviews; and (3) review relevant reports, logs, and other documentation.

### **TEST & EVALUATION ASSESSMENT**

DMLSS AIS is clearly an improvement over previous practices and systems. Release 2.0 and CSW are operating successfully and there is excellent potential for further automation of the medical logistics processes. The Release 2.0 OT&E had disclosed several issues that needed to be addressed. For example, the facility management module, despite its potential as an effective tool for managing facility maintenance, materiel, and construction projects, was not being used extensively or effectively. DOT&E made several recommendations to the PM and the medical logistics functional community for improving DMLSS AIS and the criteria used to evaluate it. The PM took action to correct the deficiencies, and the ORD was updated and revalidated. The PM is submitting an updated TEMP to OSD for approval, and OPTEVFOR will have both the requirements and guidance it needs to conduct OT&E on DMLSS AIS 3.0. The resulting assessment will determine the remaining actions necessary for DMLSS AIS to reach FOC.

## **THEATER MEDICAL INFORMATION PROGRAM (TMIP)**



The Theater Medical Information Program (TMIP) is a tri-Service system that is designed to provide information to deployed medical forces to support all medical functional areas, including command and control, medical logistics, blood management, patient regulation and evacuation, medical threat/intelligence, health care delivery, manpower and training, and medical capability assessment and sustainment analysis. TMIP will perform this service by integrating information from other medical systems, including the Composite Health Care System (CHCS), CHCS II, Defense Blood Standard System, and Defense Medical Logistics Standard Support (DMLSS). TMIP will also integrate other medical applications that have been developed for use during deployment such as the TRANSCOM Regulating and Command and Control Evacuation System. TMIP integrates medical systems at the theater level to support deployed forces, to enhance the Services' capability to collect, process, and disseminate an uninterrupted flow of information, and to allow more efficient protection of lives and resources.

### **BACKGROUND INFORMATION**

TMIP will be developed incrementally in "blocks" or "builds" of increasing functionality and integration. The military Services are expected to fund their own infrastructure (networks and communications) and computer hardware to host the TMIP software in the theater environment. The Joint Requirements Oversight Council (JROC) approved a Capstone Requirements Document (CRD) in January 1999 and the Operational Requirements Document (ORD) for TMIP Block 1 in October 1999. The JROC revalidated the Block 1 ORD in August 2001.

### **TEST & EVALUATION ACTIVITY**

In March 2001, ATEC, the lead independent OTA, conducted a Limited User Test (LUT) on a prototype version of TMIP Block 1 at Fort Sam Houston, TX, in combination with a LUT of the Army's TMIP hardware. A Capstone TEMP, along with an annex that specifically addresses TMIP Block 1, was approved in April 2001 and is being updated to reflect specific planning for Block 1 IOT&E. A program-wide Milestone B and Block 1 Milestone C decision is planned for March 2002. A joint Block 1 IOT&E is scheduled to begin in November 2002 and will be conducted over a 6-week period at a minimum of four locations, one for each of the four Services.

## **TEST & EVALUATION ASSESSMENT**

TMIP must integrate several existing and developmental systems into a single system that can be easily used by theater commanders and medical personnel in combat environments. Its heavy dependence on the successful operation of the other systems presents additional technical challenges. The functional and operational testing of each TMIP application is planned to be accomplished prior to delivery to the TMIP PM for integration. This can impose a scheduling problem for TMIP, since a delay in or problem with any application can impact the delivery of that TMIP block. This has resulted in some slippage of the schedule, and there have been some difficulties in sharing data with the various applications. However, the PM has nearly completed Block 1 integration, and independent DT&E will begin in January 2002.

For connectivity, TMIP will depend on existing (but limited) tactical communications systems that will be heavily stressed with fragmented responsibilities. While some of these situations may be unavoidable, they complicate both operational testing and operational planning and execution. DOT&E is working with the medical functional community, ATEC, and TMIP PM to address all of these issues so that a comprehensive T&E plan can be developed. It will be challenging to ensure that the testing environment mirrors the expected theater operational conditions.

During the LUT of the Block 1 prototype, ATEC determined that all of the features and capabilities that were available for testing were operationally effective, but these included only about half of the planned IOC capability. Using an Army infrastructure, TMIP successfully provided the following capabilities to deployed users: CHCS, DMLSS Assemblage Management, preparation of several Joint Task Force reports, and limited administrative processing of patients. The planned IOC capabilities that were not tested include operations using Air Force and Navy infrastructures, immunization tracking, lower echelon reporting and surveillance, and more detailed patient encounters. The TMIP Block 1 prototype was not considered suitable due to deficiencies in continuity of operations, security, and information assurance. There were also shortfalls in training and documentation.

**PART VII**

**JOINT TEST AND  
EVALUATION (JT&E)**





# JOINT TEST AND EVALUATION (JT&E)

## INTRODUCTION

The Joint Test and Evaluation (JT&E) Program has been in existence for 29 years and is designed to provide quantitative information for analysis of joint military capabilities and potential options for increasing military effectiveness. The program is complimentary to, but not a part of, the weapons acquisition process. A JT&E project brings together two or more Military Departments or other components to:

- Assess the interoperability of Service systems in joint operations.
- Evaluate improvements in joint technical and operational concepts.
- Evaluate and validate multi-Service testing methodologies.
- Assess performance of interacting systems under realistic joint operational conditions.
- Provide data from joint field tests and exercises to validate models, simulations and test beds.

The JT&E Program is managed by the Director, Strategic and Tactical Systems (D,S&TS) and is presided over by a Senior Advisory Council (SAC). The SAC is co-chaired by the D,S&TS and D,OT&E and includes representatives from the Joint Chiefs of Staff, the Assistant Secretary of Defense for Command, Control, Communications, and Intelligence and the Military Departments. Both D,S&TS and D,OT&E approve JT&E charters as well as test plans. The Senior Advisory Council prioritizes specific JT&E projects after a Defense-wide nomination process and subsequent feasibility studies.

The JT&E program provides validated answers to warfighter issues by “doing better with what we have.” Its focus remains on identifying realistic, cost-effective, solutions implementable by the Services for the programs facing today’s warfighter. Currently, there are nine joint tests. They are:

- Joint Battlefield Damage Assessment (JBDA)
- Joint Close Air Support (JCAS)
- Joint Command and Control, Intelligence, Surveillance, and Reconnaissance (JC2ISR)
- Joint Cruise Missile Defense (JCMD)
- Joint Global Positioning System Combat Effectiveness (JGPSCE)
- Joint Methodology to Assess C4ISR Architecture (JMACA)
- Joint Shipboard Helicopter Integration Process (JSHIP)
- Joint Theater Distribution (JTD)
- Joint Unmanned Aerial Vehicles (JUAV)

There were four Joint Feasibility Studies considered for continuation as Joint Tests during the past year. Because of funding limitations and critical government personnel requirements, only the two highest priority programs of the SAC, Joint Methodology to Assess C4ISR Architecture (JMACA) and Joint Unmanned Aerial Vehicles (JUAV), were selected as new start JT&E efforts.

The JMACA Joint Test will assess and validate the integrated architecture assessment methodology found in Command, Control, Communication, Computer, Intelligence, Surveillance and Reconnaissance (C4ISR) that meets the following requirements:

- Timely assessment: reduce set up time for a Joint Task Force (JTF), identifying architecture improvements, and solving interoperability issues.
- Supportable process: use a small cadre of support personnel.
- Adaptable methodology: evolve as new warfighting concepts and technologies are fielded.
- Integration with the Joint Task Force: be part of the JTF Planning process.

The JMACA JT&E concept is to use *methodology* as the test article and *integrated architectures* as test resources. The test approach will be to validate methodology using a mini-test, two test events, and an operational event, and then assess the impact of improvements. The methodology will involve the use of coarse analytical tools as “preprocessors” to identify high-risk areas across the breadth of the architecture, then to use higher resolution tools and procedures to selectively analyze in depth the high-risk areas identified by the analytical tools, and finally to identify and recommend solutions that enhance capabilities or mitigate limitations of the architecture.

The Navy is the lead Service for the test with the Army, Marines, and Air Force participating. When fully staffed, JMACA will have ten uniformed military personnel and one government civilian, plus support contractors. The JMACA JT occupies a leased building in Suffolk, Virginia, in the vicinity of the USJFCOM J7 and J9 facilities.

The JUAV JT&E will specifically address and evaluate three alternative processes and procedures for the integration of the UAV into the Joint Tactics Techniques and Procedures (JTTPs) that govern time sensitive operations. Test methodology is designed to evaluate the effectiveness using these alternative procedures. The JT&E will execute a three-phase test program to refine, evaluate, and validate proposed alternative processes and procedures: Phase 1, Simulation to refine alternatives; Phase 2, Field Tests to evaluate the alternatives; and Phase 3 Joint Exercises to validate the alternatives. The JT&E will develop, document and disseminate conclusions and recommendations regarding the JTTP alternatives following each test activity. This procedure will enable new and proven processes and procedures to be rapidly disseminated to the joint warfighter throughout the duration of the JT&E.

The Navy is the lead Service with the Army, Marines, and Air Force participating. When fully staffed, JUAV will have fourteen uniformed military personnel and three government civilians, plus support contractors. The JUAV JT occupies government facilities at Fallon NAS, NV.

The other two studies, Joint Anti-Terrorism/Force Protection (JAT/FP) and Joint Aircraft Survivability to Man-Portable Air Defense Systems (JASMAN) are to complete JT&E reporting with remaining funding. As a result of the terrorism events of September 11, 2001, JAT/FP received required funding to begin testing outside the JT&E program.

In addition to the ongoing joint tests, this year there are two new feasibility studies. Upon completion of a one-year study period, the SAC will review these studies as potential projects; and either one or both will be selected as full joint test projects. These new feasibility studies are listed below:

**Joint Battlespace Integration Test (JBIT)** - The study is intended to identify test methodologies for evaluating current and next generation family of systems testing with an integrated

battlespace. Such a concept would allow both the warfighter and the developer to conduct evaluations of the interoperability of the families of systems. This would solve the problem of the current platform centric, service centric, test and evaluation of families of systems without assuring interoperability.

**Joint Logistics/Planning Enhancement (JLOG/PE)** - The study is intended to investigate the C2 information architecture and component interfaces for near real time information on systems and classes of supply status and identify enhancements in joint logistic and operational planning and execution processes. Each of the Services have unique support systems with on-demand information but the joint commander does not get timely inputs.

Two programs were finalized this past year: Joint Warfighters (JWF) and Joint Suppression of Enemy Air Defenses (JSEAD). At the request of the Joint Requirements Oversight Committee (JROC), JSEAD is being considered for establishment as a permanent mission area organization.

This Page Is Intentionally Left Blank

## JOINT BATTLE DAMAGE ASSESSMENT (JBDA)



The charter of the Joint Battle Damage Assessment (JBDA) Joint Test & Evaluation (JT&E) is to investigate, evaluate, and improve BDA support to the joint force commander in order to facilitate operational decision making. Potential improvements will be identified, prioritized, and coordinated with the appropriate commands.

The JBDA JT&E will establish a baseline case by evaluating and documenting current BDA processes and procedures in operational scenarios. Potential deficiencies and opportunities for improvements will be identified. The selected improvements will then be installed and tested in environments as closely aligned with baseline measurements as possible. Analysis of the collected data will be used to evaluate the effectiveness and suitability of the proposed enhancements. For the JBDA JT&E, the Army, Navy, Air Force, Marine Corps and Unified Commands are designated as participating Services/Commands, with the Army designated as the lead Service and executive agent.

### **BACKGROUND INFORMATION**

At the conclusion of *Desert Storm*, BDA was identified as one of the four major intelligence shortcomings. "The BDA process was difficult especially for restrike decisions. BDA doctrine and organization must be determined" (Department of Defense [DoD] Final Report to Congress, *Conduct of the Persian Gulf War*, 1992). DIA, the Services and the unified and specified commands have begun to institutionalize a BDA structure that will satisfy combatant commanders' requirements." (Department of Defense, *Final Report to Congress of the Persian Gulf War*, April 1992)

*Desert Storm* outstripped intelligence collection and analysis capabilities, sharply reducing BDA effectiveness. This was further exacerbated by the lack of trained analysts and doctrine that specified BDA production responsibilities. Beginning immediately after the war, DoD addressed the BDA problems in *Desert Storm* by reorganizing targeting activities within DIA. DIA created the Deputy Directorate for Targets (J2-T) as the single national level point of contact for targeting matters, and formed a BDA Working Group under the existing Military Targets Intelligence Committee.

The BDA improvements and changes following *Desert Storm* have been incorporated – at least in part – in subsequent contingencies and operations. The first operation that included enough targets to effectively exercise BDA was *Desert Fox*. With its scripted nature, short duration, and very limited target development, *Desert Fox* was not a vehicle for determining whether or not *Desert Storm* BDA problems were fixed. For example, while *Desert Storm* found that there was a critical need to develop a

process for maneuver force BDA, *Desert Fox* emphasized infrastructure and not ground force equipment. CINCCENT stated that he had “seen no seams in the intelligence community in terms of differences of opinion,” and that BDA had been rapid, responsive, and well analyzed. BDA worked in *Desert Fox*. The CINC was satisfied, and it appears that members of the intelligence community worked well together. However, *Desert Fox* did not answer the question of whether or not *Desert Storm* BDA problems were fixed; the operations were simply too dissimilar.

The second significant combat operation subsequent to *Desert Storm* was *Allied Force*. This was a North Atlantic Treaty Organization (NATO) air operation against the Federal Republic of Yugoslavia, running from 24 March through 20 June 1999. Federated BDA was used during *Allied Force*. The target sets were federated between USEUCOM (the USEUCOM-established Joint Task Force was designated as the BDA authority) and the NMJIC. As in *Desert Fox*, Federated BDA mitigated some of the coordination problems and appeared to increase BDA responsiveness.

*Allied Force* and *Desert Storm* shared some common characteristics including some pre-conflict buildup and training; coalition forces; sanctuaries; aircraft and cruise missile strikes; and target development throughout the operation. One of the major differences in the two operations was scale – the numbers of strike aircraft, numbers of sorties, numbers of bases, and geographical area. *Desert Storm* was larger in almost every category. There was also a vast difference in the BDA focus for the two operations. *Desert Storm* emphasized ground force targets, while the same targets were fourth on the *Allied Force* target list. Finally, the tempo of operations was continuous in *Desert Storm* and intermittent in *Allied Force*.

*Desert Fox* and *Allied Force* illustrated that advances have been made in BDA since *Desert Storm*. At the same time, these two operations highlight the need for further improvement. Training of analysts is still problematic. Processes and procedures are in place for conducting BDA on fixed targets, but these processes can and should be enhanced to provide BDA in a more timely and accurate fashion to meet the commander’s decision cycle. Finally, there has been little focus or effort on improving mobile target BDA since *Desert Storm*.

To address these recurring shortcomings, the Deputy Director, Test and Evaluation (DDT&E), under the Director, Test, Systems Engineering and Evaluation (DTSE&E), Office of the Secretary of Defense (OSD), directed the Joint Battle Damage Assessment (JBDA) Joint Feasibility Study (JFS) in June 1999. The Army was designated as the lead Service, and responded quickly to the SAC’s guidance, moving the JFS sponsorship to the Training and Doctrine Command (TRADOC) and assembling the initial staff.

## **TEST & EVALUATION ACTIVITY**

During this past year, the JBDA JT&E participated in Ulchi Focus Lens (UFL 01) to provide continuity between the Joint Warfighters JT&E as it ceases testing and this follow-on JT&E begins. The Program Test Plan was developed and is in final stages of coordination at this time.

## **TEST & EVALUATION ASSESSMENT**

The JBDA JT&E program meets the stated purposes of the OSD JT&E Program and the Services and CINCs continue to support the project. Resources and planning are on track to support continued field testing.

## JOINT CLOSE AIR SUPPORT (JCAS)



Joint Close Air Support (JCAS) is a DoD Joint Test and Evaluation (JT&E) program chartered by OSD to assess the current capabilities of U.S. forces to conduct joint close air support (CAS) in both day and night conditions. The JCAS Joint Test Force (JTF) will also test and recommend potential enhancements to improve joint CAS effectiveness. To do this, the JTF will employ multi-Service air and ground equipment and personnel in realistic combat training scenarios. The test will address two critical issues:

1. What is the joint CAS baseline effectiveness?
2. What changes to Joint CAS Tactics, Techniques, and Procedures (JTTP), equipment/systems, and training increase effectiveness compared to the baseline?

### **BACKGROUND INFORMATION**

The last DoD joint test of CAS JTTP was completed more than a decade ago. Since then, new weapons and support systems technologies such as Global Positioning System, secure communications, advanced electronic warfare devices, and night-vision devices have been adopted by both ground and air forces. As interactions among ground and air support forces evolved, corresponding JTTP for effective CAS developed in an *ad hoc* manner. Service manpower levels combined with an increased operational tempo have potentially had an adverse effect on CAS training and operational readiness. JCAS is intended to benchmark CAS operational effectiveness today and offer improvements for the future.

JCAS was chartered in 1997 following a feasibility study. In the first year, the JTF completed and OSD approved the JCAS program test plan. The JTF coordinated and completed signed memoranda of agreement with all necessary support units and arranged operations facilities. At the suggestion of the Joint Chiefs of Staff, the JCAS charter was expanded in 1998 from *Joint Night CAS* to *Joint CAS* to address both day and night CAS operations.

The primary JCAS test site is the National Training Center (NTC) at Ft. Irwin, CA. The JCAS JTF conducts testing at NTC on a non-interference basis with regularly scheduled brigade-level training sessions conducted by rotating Army operational brigades against a permanent opposing force stationed at NTC. The Air Warfare Center at Nellis AFB, NV provides CAS attack and forward air controller airborne sorties.

Initial test operations began with a mini-test conducted in November 1998 at NTC to determine the contribution of visual control of CAS aircraft in daylight, medium altitude conditions. JCAS field-testing began in earnest in March 1999. Since then, the JCAS JTF has completed data collection, reduction, and analysis of nearly 40,000 data elements addressing over 200 joint CAS measures. The JTF published the *JCAS Interim Report* in 2000, focusing on the day joint CAS baseline. The focus of future testing will be on the night joint CAS baseline and evaluating proposed joint CAS enhancements.

### **TEST & EVALUATION ACTIVITY**

In fall 2000, the JTF refined the instrumentation and data requirements for Twentynine Palms and in January and February deployed there for data collection. At Twentynine Palms, the JTF verified they could deploy to an alternate venue, collect CAS data on a different Service, employ a man-portable instrumentation system, and instrument a non-instrumented range. JCAS also verified their data collection procedures and CAS model are valid in another venue. Ongoing deployments to the National Training Center (NTC) and Twentynine Palms allow the continual refinement of instrumentation and data collection requirements.

The JCAS JTF wrote chapters 3, 4, and 5 (Planning, Preparation, and Execution) of the new Joint Pub 3-09.3, Joint Tactics, Techniques, and Procedures for Close Air Support (CAS) and pivotally engaged in the development of the JROC-sponsored CAS Joint *Concepts Requirements Document* (CRD).

### **TEST & EVALUATION ASSESSMENT**

JCAS is a needed test at the right time. Experts in the CAS world routinely look to the JCAS JTF to formulate recommendations for improvements to joint CAS operations. As our weapon systems become more capable and potential enemy forces become steadily more capable, U.S. forces must capitalize on the strengths of leading-edge technology. While many weapon systems embody impressive technical functions, their actual employment on the battlefield as part of a greater strategic picture will determine the outcome of future combat. By leveraging off the large-scale and realistic brigade-level combat training at NTC and other training venues like MCAGCC, JCAS promises to provide realistic information that can be used to direct future research and development activity toward efforts with the greatest potential benefits.

DOT&E supports the continuation of the JCAS efforts and agrees with the need to continue this effort as requested by the Joint CAS ESC as a legacy organization that can assist in the improved effectiveness of this critical mission area as technological improvements and enhancements are introduced.



## JOINT COMMAND AND CONTROL, INTELLIGENCE, SURVEILLANCE AND RECONNAISSANCE (JC2ISR)



The objective of this Joint Test and Evaluation (JT&E) program is to improve Joint operations by providing recommendations to enhance Joint C2ISR tactics, techniques, and procedures (TTP), operational concepts, training and systems. JC2ISR will enhance the Joint warfighter's ability to utilize diverse national, theater, and tactical collection sensors and dynamically focus them to identify, locate, track, and engage high value, mobile surface targets. Recommendations resulting from JC2ISR will significantly improve the Joint Force Commander's ability to integrate assigned organic and higher echelon platforms and sensors in a coordinated (cross-cued) and cooperative (simultaneous) collection strategy. The results of this JT&E will provide decision-makers significantly improved C2ISR tasking, processing, exploitation, and dissemination (TPED) to support time critical targeting and are applicable to all Joint warfighters.

### **BACKGROUND INFORMATION**

Unified Commands, Services, and National Intelligence Agencies currently devote significant resources in an effort to improve Joint warfighter's ability to engage time critical targets (TCTs). Recent military operations (e.g., Operations Desert Storm, Desert Fox, and Allied Force) confirm our inability to identify, locate, track, and engage fleeting, mobile targets. Simply put, enemy mobile targets are vulnerable for a shorter period of time that it takes to engage them using current procedures. A major contributor to this limitation lies in C2ISR TPED shortfalls conducting dynamic operations. Lessons learned from these military operations identify requirements for highly discriminate targeting information and avoidance of collateral or unintended damage despite poor weather and adversary countermeasures. The unaided human decision and C2ISR TPED cycle are too slow to respond to fleeting targets that can "*shoot and scoot.*" Although we possess some ability to preplan countermeasures against TCTs using Intelligence Preparation of the Battlespace (IPB), uncertainty as to the specific what, where, when, how, and why of enemy employment typically places TCT detection, identification and location inside the time cycle for preplanned operations.

The Office of the Director, Strategic and Tactical Systems (ODS&TS), Office of the Under Secretary of Defense for Acquisition, Technology, and Logistics (OUSD AT&L) chartered JC2ISR to employ multi-Service and other Department of Defense (DoD) agency support, personnel and equipment to investigate, evaluate, and make recommendations to improve the operational effectiveness of Joint C2ISR. Specifically, JC2ISR will test and evaluate the Joint Task Force and Components' ability to

dynamically task and re-task ISR collection platforms and sensors and their ability to process, exploit, and disseminate combat information to support time critical targeting. The JC2ISR JT&E program will baseline current C2ISR processes used to prosecute TCTs, identify ISR platform and sensor tasking, processing, exploitation, and dissemination deficiencies, and identify opportunities for Joint C2ISR improvements.

### **TEST & EVALUATION ACTIVITY**

JTF personnel conducted Risk Reduction #2 efforts at Roving Sands 01, June 15-24, 2001 with several objectives that were satisfied: identified baseline architectures (operational, and system), TST TTPs, and existing Roving Sands data collection capabilities; identified the live IPB (Intelligence Preparation of the Battlespace) process and IPB interfaces with TPED operations; and, the JTF also collected sample data, developed a venue integration concept, estimated JT&E staffing for Mini-Test (MT) 3.

JTF personnel performed/observed multiple tasks during JTFEX 01-2 that enabled them to more effectively execute JC2ISR's first mini-test (MT-1) during JTFEX 01-3. In JTFEX 01-3, conducted from August 6-19, 2001, the JTF team assisted the Second Fleet personnel with the development of the TCS (Time Critical Strike) Tactical Memorandum (TACMEMO).

Analysis of MT-1 will be finalized and published in the upcoming fiscal year.

### **TEST & EVALUATION ASSESSMENT**

The JC2ISR JT&E program meets the stated purposes of the OSD JT&E Program and the Services and CINCs continue to support the project. Resources and planning are on track to support continued field testing.

## JOINT CRUISE MISSILE DEFENSE (JCMD)

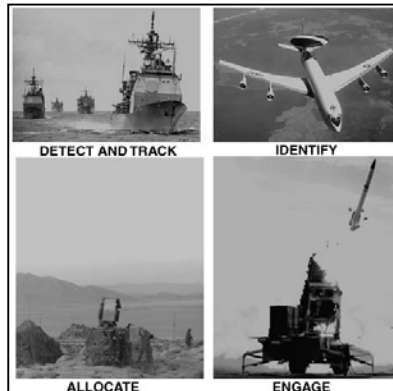

OSD chartered the Joint Cruise Missile Defense (JCMD) JT&E to employ multi-service and other DoD agency support, personnel, and equipment to investigate, evaluate, and improve the operational effectiveness of joint defenses against cruise missiles (CM). The JT&E will identify a baseline capability by evaluating and documenting current JCMD processes and procedures in realistic operational scenarios. The JT&E will identify and select potential enhancements to the JCMD process and will test those enhancements in environments as closely aligned with baseline measurements as feasible. The Full-Dimensional Protection pillar of Joint Vision 2010 addresses the need to protect US forces from the very technologies that the U.S. is attempting to exploit. The JCMD JT&E will address the number-one priority of the Full-Dimensional Protection pillar: countering air and missile threats.

The Joint Cruise Missile Defense mission area is the integrated efforts of a Joint Integrated Air Defense System (JIADS) to counter a CM threat. The JT&E will address all five elements of the JIADS CM kill chain: Detect, Track, Identify, Allocate Assets, and Engage.

### **BACKGROUND INFORMATION**

With the aid of a Joint Working Group, the JCMD staff formulated the following problem statement on JCMD for the JT&E: *“The Joint Integrated Air Defense “Family of Systems” capability to meet the cruise missile threat has not been fully explored.”*

The term “Family of Systems” refers to the collection of individual systems that make up the JIADS. The family includes command, control, and communications assets (E-3 aircraft, E-2 aircraft, ground systems, etc.), shooter assets (fighter aircraft, Patriot, Aegis, etc.), and all the other principal systems resident in a theater that can perform one or more JIADS functions. The JCMD JT&E will test current (2002) JIADS JCMD capability, identify problem areas, and then test implemented improvements and enhanced JIADS JCMD capability (2003). The selected methodology for the JT&E includes a mix of joint field tests with operational units involved in the joint air defense mission and of multipurpose, interactive simulations. This test approach provides the ability to assess the effectiveness of a joint force’s ability to counter the CM threat, identify critical problem areas, define potential enhancements, and assess the effects of the enhancements on the mission effectiveness of a joint integrated air defense force. The JTF will develop and leave behind a series of legacy products designed to institutionalize the work and results of the JT&E.

The first JCMD JT&E field activity, the MT, occurred in Feb-Mar 2000 in conjunction with the All Service Combat Identification Evaluation Team (hereafter called by a new title of Joint Combat Identification Evaluation Team (JCIET)) evaluation. Air defense is a major objective of the JCIET evaluation and featured participation by a JCMD-supplied CM surrogate as part of the threat forces. The JTF met all MT objectives and demonstrated the capability to integrate with the JCIET evaluations, coordinate CM surrogate operations, and collect data. Subsequent field tests will also use the JCIET evaluations as the venue of choice.

### **TEST & EVALUATION ACTIVITY**

The JTF analyzed the MT data and produced the MT final report in December 00. Exercise Amalgam Virgo took place June 1-2, 2001. The goal of the exercise was to increase the capability to detect, track, and intercept CM and unmanned aerial vehicle (UAV) threats, using forces under NORAD Control. All simulated CM and UAV launches occurred June 2, 2001. Overall, eight MQM-107 drone CM surrogates were launched during the exercise and four BD-5 (UAV surrogate) sorties were flown. Simulated engagements occurred against all drone and BD-5 sorties. JCMD participation included continuing data collection and risk-reduction efforts for the FT-1/JCIET activity as well as the observation of JIADS system performance.

### **TEST & EVALUATION ASSESSMENT**

The JCMD JT&E program meets the stated purposes of the OSD JT&E Program and the Services and CINCs continue to support the project. Resources and planning are on track to support continued field testing.

## JOINT GLOBAL POSITIONING SYSTEM COMBAT EFFECTIVENESS (JGPSCE)



The Joint Global Positioning System Combat Effectiveness (JGPSCE) Joint Test Force is chartered to evaluate the impact of electronic warfare targeted against global positioning system (GPS) receivers in joint operations. GPS provides highly accurate, real time, passive, common-reference grid position and time information to military and civilian users worldwide. GPS enables the military forces to determine their position, velocity, and time. GPS will: (1) enhance command and control and coordinate battle tactics and support; (2) engage in strategic and tactical warfare; (3) maneuver efficiently on the battlefield; (4) provide accurate and timely fire support; and (5) facilitate combat service support operations. In addition, knowledge of the exact position and time is essential to reconnaissance and intelligence missions.

### **BACKGROUND INFORMATION**

In July 1999, the Office of the Under Secretary of Defense, Director, Test, Systems Engineering and Evaluation, chartered the JGPSCE joint test and evaluation (JT&E) to address three issues:

- What is the impact of GPS vulnerabilities on the effectiveness of joint operational missions requiring precision engagement?
- What changes in joint tactics, techniques, and procedures or system-level mitigation techniques improve or maintain joint operational effectiveness in the event of GPS electronic warfare and electromagnetic interference?
- What test methodologies can be employed to characterize GPS vulnerabilities in future acquisition and integration programs?

JGPSCE JT&E will conduct three phases of testing, implemented by four tests events, each examining an increasing level of warfare. The three phases of warfare are: (1) Small Scale Contingency; (2) Limited Engagement; and (3) Major Theater War. Each level represents a major concern for DoD planners today, as well as presents unique problems in maneuver, engagement, and logistics/force protection. All are highly dependent on secure, high-speed communications.

Each of the three test phases is designed to provide information relating to key information upon which warfighters can base subsequent decisions. Each phase will use jamming of GPS in the open air to

be as realistic as possible. Each phase will look at the impact of GPS electronic warfare and electromagnetic interference by comparing baseline performance to performance after the electronic warfare and electromagnetic interference occurs. Each phase will also introduce mitigation techniques and procedures developed during test planning, and look at the ability of troops and commanders to operate in a GPS degraded or denied environment. Thus, each of the three phases will be immediately useful to theater commanders and DoD.

*Phase 1* testing consists of two live test events, GYPSY ALPHA and GYPSY BRAVO, at the tactical level of warfare. These tests focus on determining GPS electronic warfare and electromagnetic interference vulnerabilities and mitigations for few-on-few engagements during small-scale contingencies. Each of the two live tests in Phase 1 will concentrate on portions of the sensor-to-shooter architecture.

*Phase 2* testing will consist of one live test event, GYPSY CHARLIE. The focus of this test will be on integrated system-of-systems tactical-level mission performance and integrated system-of-systems operational-level mission performance during limited engagement operations.

*Phase 3* testing will consist of a single test, GYPSY DELTA, which will evaluate integrated tactical and operational level systems and warfighters performing missions during a major theater of war scenario.

Planning for GYPSY BRAVO (GB) continues with captive carry in Dec 01 at Fallon and live drop of precision weapons in Mar 02 at the UTTR (Utah Test and Training Range). GB plans focus on the F-16, F-15E, F/A-18, EA-6B, and AH-64D platforms delivering JDAM, JSOW, AGM-130, EGBU-15, and HELLFIRE.

## **TEST & EVALUATION ACTIVITY**

GYPSY ALPHA (Field Test #1) testing was conducted during the months of October and November 2000. This test consisted of ground forces supplemented by limited airborne forces. This test was highly successful and the analysis nears completion. GYPSY ALPHA Final Report has completed external review and is in technical editing. A “road show” briefing of test results will be provided down to user level organizations.

## **TEST & EVALUATION ASSESSMENT**

The JGPSCE JT&E program meets the stated purposes of the OSD JT&E Program and the Services and CINCs continue to support the project. Resources and planning are on track to support continued field testing. Results of this JT&E will be extremely beneficial to the execution of war fighting capability.

## **JOINT SHIPBOARD HELICOPTER INTEGRATION PROCESS (JSHIP)**



The Joint Shipboard Helicopter Integration Process (JSHIP) Joint Task Force was chartered to develop and evaluate a standard process for the integration of multi-Service rotorcraft, aircrews, and embarked units aboard air-capable U.S. Navy ships. The JSHIP Joint Task Force conducts flight tests, critical measurements, engineering analyses, and simulations to provide recommended changes to Joint tactics, techniques, and procedures; training syllabi; and rotorcraft/ship designs that will enhance safe, rotorcraft/ship interoperability. Only Special Operations Forces (SOF) and Army helicopters will normally be targeted for schedule inclusion. National Guard assets will also be considered if helicopter type and model are available. Expected products from the JSHIP program include expanded launch and recovery flight envelopes for 12 helicopter/ship combinations and ship certification of 12 specific helicopter/ship pairs.

### **BACKGROUND INFORMATION**

The JSHIP Joint Test and Evaluation (JT&E) program was chartered by OSD on July 22, 1998, following the completion and acceptance of a Joint Feasibility Study initiated in June 1997. All Services and Unified Commands are designated as participants, with the Navy as the lead service and executive agent for the program. A General Officers Steering Committee was established to provide the Joint Test Director a forum for senior-level counsel and advice. DOT&E and DD(DT&E), S&TS provided co-signature approval of the Program Test Plan on September 30, 1999.

Four separate Dedicated at Sea Tests (DASTs) were successfully conducted in FY00. The test tempo provided heavy volumes of data and proved to be a major task for the JSHIP program to process, analyze, prepare individual final test reports, and adhere to the anticipated schedule. An internal review of the program objectives and schedules identified the need to extend the program for an additional year. Authorization to extend the program through FY03 was granted on June 10, 2000.

JSHIP is leading the development and verification of the Dynamic Interface Modeling and Simulation System (DIMSS) software effort. DIMSS is a joint development with the NASA Ames Vertical Motion Simulator (VMS) group to perfect a high fidelity, dynamic cockpit pilot trainer for UH-60A/LHA training simulations. The Army and SOF commands have expressed interest in the use of DIMSS for training. Separately, the DIMSS software will provide the Navy with a full tool set for air-

wake modeling and wind-over-the-deck analysis and prediction. The DIMSS effort spanned FY00 and should complete by 1QFY02.

To date, the JSHIP program has conducted six JSHIP Warfighter Conferences with multi-Service representation to review program progress, identify test asset requirements, and to more closely identify current issues as viewed by the operating forces.

## **TEST & EVALUATION ACTIVITY**

DIMSS software development has progressed to the point where data collected on the early DAST events is being used to validate the DIMSS pilot trainer at NASA Ames. A month long simulation assessment was conducted in June 2001 with ten pilots from all services flying the trainer. Another short assessment was conducted in August to verify changes made as a result of the first assessment. Army funds were provided to complete the assessment because of the heightened interest of the Army in using the DIMSS software as an integral part of its flight simulator pilot training.

Five DAST events occurred in FY01. DAST-1A was conducted in November 2000 with Army UH-60A and CH-47D aircraft on LHA 5, USS Peleliu. The main focus of the test was to gather more data to support DIMSS validation. DAST-4 occurred in February 2001 with SOF MH-53J, SOF CH-47D, and Army OH-58D aircraft onboard CVN 69, USS Eisenhower. DAST-5 occurred in May 2001 onboard LSD 51, USS Oak Hill and focused on the Army AH-64D. DAST-6 occurred in July 2001. DAST-6 involved 11 AH-64, CH-47D, and UH-60A aircraft from the Texas Army National Guard operating from LHA 1, USS Tarawa off Southern California. The National Guard provided approximately 250 personnel to support the test that focused on use of the procedures and processes developed to date by the JSHIP program. DAST-7 involving Texas Army National Guard CH-47D, AH-64, and UH-60A aircraft on the smaller decked LPD 6, USS Duluth, was started on July 8 but was cancelled on July 10 due to a ship boiler failure. Collection of test data was limited due to the cancellation.

The Dynamic Interface Test Reports and Final Reports for DAST-1 through DAST-4 have been published and released to all participating Services. These reports and special reports, such as the SD-2 Spotting Dolly Report, clearly identify areas of concern and procedures/equipment that should be avoided. Alternative procedures/equipment have also been recommended where appropriate.

## **TEST & EVALUATION ASSESSMENT**

The JSHIP program has documented results of tests in the form of data bases to be available to future commanders. The data bases include specifics on weapon susceptibility to RF emissions, spare parts and repairs capabilities of each type host ship, and operating procedures. Should an Army or SOF commander be tasked with shipboard operations, he can identify compatibility, procedures, training, and safety issues that must be addressed prior to and during deployment on the ship. This information repository was not available during earlier joint shipboard operations in Granada or Haiti. The beta-test of the data was the purpose of the DAST-6 evolution aboard the Tarawa in July 2001.

The DIMSS development and test demonstrations have provided the Army and SOF pilot training communities with a high fidelity trainer to safely teach UH-60 pilots the flight procedures necessary to operate with a LHA. More importantly, the actual test data collected to validate the



software will provide the Navy with a potent tool to evaluate and expand flight envelopes for rotorcraft/ship operations at a cost well below the current \$500,000 per ship type currently incurred.

DOT&E strongly supports the JSHIP program objective to test and document helicopter/ship pair interoperability to support future safe, Joint Service operations. Although the actual DAST evolutions are more developmental than operational tests, the JSHIP program successfully captures multi-Service participation to produce valuable JSHIP products for future operational use. The “legacy” data bases will be of future value. The DIMSS effort to both develop an operational flight trainer and use the software as a tool to support future Dynamic Interface test efforts is a noteworthy and value-added example of successfully integrating modeling and simulation into acquisition, testing and training.

This Page Is Intentionally Left Blank

## JOINT SUPPRESSION OF ENEMY AIR DEFENSES (JSEAD)



The Joint Suppression of Enemy Air Defenses (JSEAD) Joint Test and Evaluation (JT&E) was chartered by OSD to characterize the reactive JSEAD targeting process, baseline current capabilities, quantify element contributions to that process, identify deficiencies, and test and evaluate potential improvements. The program issue, as developed through analysis of warfighter concerns, is: *Do end-to-end JSEAD targeting process enhancements improve reactive, localized JSEAD effectiveness?*

JT&E will result in recommendations for improving the end-to-end reactive JSEAD effectiveness of U.S. forces and reducing enemy Integrated Air Defense System (IADS) capabilities.

### **BACKGROUND INFORMATION**

Warfighting commanders require the capability to conduct effective JSEAD operations to sever an enemy's IADS by targeting key command and control and air defense assets. JSEAD operations apply pre-planned (pre-emptive) and opportune (reactive) targeting, whereby commanders employ both destructive (seek out and destroy) and disruptive (temporarily deny, degrade, deceive, delay or neutralize) force application methods. Since the Gulf War, the JSEAD strategy has emphasized pre-emptive targeting and destructive force application methods. However, the surface-to-air missile threat is becoming more technologically sophisticated and mobile, and therefore more difficult to pre-emptively target. With fewer dedicated JSEAD assets to perform reactive JSEAD in this increasingly hostile air defense environment, there is a need to improve the Joint Force Commander's ability to conduct reactive JSEAD more effectively and efficiently using existing Service assets.

The JSEAD JTF performed two field tests in 1998: (1) a live-fly exercise (LIVEX 98) employing multi-Service participants, Red Flag resources, during the conduct of a Green Flag Exercise at Nellis AFB; and (2) a Computer-Assisted Exercise (CAX 98) at the Air Force Battlestaff Training School at Hurlburt Field, FL. Each test included an initial set of trials to establish a baseline for evaluation of the associated test issue and a second set of trials to allow measurement of enhancement impacts. Tests planned for 1999 were cancelled due to priority commitments of key test assets to support combat operations against Iraq and the Former Republic of Yugoslavia. The JTF provided valuable findings from JSEAD's 1998 tests to decision makers responsible for those combat operations.

JSEAD's final test, LIVEX 00, was conducted at Nellis AFB from August 26-September 8, 2000, using Green Flag as its test bed. LIVEX 00 Combat Forces included airborne alert aircraft dedicated to

reactive JSEAD targeting with standoff weapons (USAF F-15Es with AGM-130s and USMC F/A-18Ds with JSOW). Suppression aircraft included EA-6Bs, EC-130s and F-16CJs. JSEAD operations in LIVEX 00 were set in a realistic scenario with other aircraft assigned primary combat missions of Counter-air and Interdiction. A Battlefield Coordination Detachment and a Naval/Amphibious Liaison Element directed notional JSEAD engagements by Army Tactical Missile System and Navy Tomahawk Land Attack Missile respectively. These were the only notional weapons systems in the test.

The test featured over 1,000 aircraft sorties in a realistic air defense environment, a rich ISR collection capability, advanced intelligence processes, and the exercise of command and control over the joint forces. The JTF meticulously instrumented all participants to support rigorous analysis and meet original JT&E charter objectives. The JTF completed reconstruction, analysis and reporting of LIVEX 00 as well as its overall test program in FY01.

### **TEST & EVALUATION ACTIVITY**

Ongoing reconstruction and analysis efforts continued through all of 2001. Support to JCS J8 Force Protection Division on the JSEAD Joint Mission Area Analysis (JMAA) was provided. JSEAD reviewed the JMAA discrepancies, identified those that this JT&E addressed, measured, noted, or observed during the tests and those the JTF recommended fixes or improvements to. The JTF also suggested other discrepancies be worked by a follow-on organization. Significant effort went into developing the 'Nellis Live-Fly Lessons Learned' legacy product. Tactical Intelligence Broadcast System corruption and data fidelity were major concerns for the intelligence, surveillance, and reconnaissance (ISR) reconstruction and analysis team. Analysis subjects for the final reports included: imaging intelligence reports, sensor capability, ISR time plotting, and Command and Control (C2) actions. Operations and Plans members also drafted sections of the final report describing findings, conclusions, and recommendations. In May, the Operations and Plans personnel completed writing the final report and began the peer review process. Subject Matter Experts (SME) reviewed the JSEAD developed CONOPS for publication in the final report as an attachment. The complete JSEAD JT&E Final Report was submitted to the Program Office for review July 17, 2001. The JSEAD Joint Test Director Management Report was submitted in August 2001.

A JSEAD Final Report briefing will be presented to all appropriate agencies once approved by the Joint Program Office.

### **TEST & EVALUATION ASSESSMENT**

The results of this test provide definitive requirements for a reassessment of the JSEAD mission area.

The results have been briefed to the Joint Requirements Oversight Committee and were endorsed as highly beneficial to the Services. The Air Force has been tasked to look into the establishment of a permanent JSEAD testing agency.

## JOINT THEATER DISTRIBUTION (JTD)



Joint Theater Distribution (JTD) is the system that enables the geographic combatant commander to deploy, employ, sustain, and re-deploy assigned forces and non-unit materiel and personnel to carry out missions assigned to his command. The system is a network of nodes and links tailored to meet the logistic requirements of the military force during peacetime, contingency, or wartime operations. The purpose of the JTD Joint Test and Evaluation (JT&E) is to examine, standardize, and streamline the theater distribution pipeline nodal processes to enhance theater distribution effectiveness and efficiency, with the goal of reducing customer wait time. The Army is the Lead Service for this Joint Test and Evaluation Program.

This five-year test is designed to quantitatively/qualitatively measure the effectiveness and efficiency of the DoD distribution system using a business process reengineering methodology to enhance theater distribution through the application of better business practices within the in-theater distribution nodes. JTD JT&E focuses on in-theater distribution, but will include an examination of other end to end distribution pipeline operations, both strategic and tactical, when they impact theater distribution.

### **BACKGROUND INFORMATION**

Recent and on-going military and humanitarian operations highlighted difficulties in managing the in-theater distribution of assets, the related information flows, and the integrated management processes necessary for the geographic CINC to execute his directive authority for logistics support. Simply stated: To provide the “right support to the right customer at the right time, the first time.” The sheer volume of materiel to be moved through the theater distribution nodes during the early phases of deployment and sustainment operations overwhelm the node’s ability to execute distribution. These nodes are where unique Service systems and units must hand off cargo and materiel in a seamless fashion to avoid backlogs and bottlenecks. Experience has shown that this is where the distribution process tends to break down. This test addresses the nodes’ underlying business processes and focuses on their improvement as opposed to the traditional approach of investigating the nodal resources required to execute distribution.

The JTD JT&E project was chartered by OSD on September 8, 1998. The JTD JT&E is being conducted using a team of Service and contractor personnel. In year one, the JTD JT&E conducted visits to multiple sites within the Pacific Command (PACOM) and European Command (EUCOM). The visits

focused on mapping the “As Is” discrete nodal physical processes, information flows, and management processes occurring within the Aerial Ports of Debarkation (APOD), Seaports of Debarkation (SPOD), Hub/Advanced Logistic Sites (ALS), Trailer Transfer Points (TTP), Terminal Transfer Units (TTU) and the Customers. This information was used to develop test articles for each of the planned test treatments, and to build models unique to each type distribution node in a CINC’s Area of Operation (AOR). In the second year, “As Is” mapping in the Central Command (CENTCOM) AOR was completed and the first test treatments were applied in PACOM and EUCOM. During the third year of the test, “As Is” mapping in the U.S. Southern Command (SOUTHCOM) was conducted and additional testing was conducted in PACOM and EUCOM. In the fourth year, the JTD JT&E will formulate the best joint business process for each in-theater distribution node type and test these process changes on a global basis in at least three CINCs AOR.

The Program Test Plan was approved on March 7, 2000. Previous test activities included the baseline mapping of the theater distribution process in CENTCOM and SOUTHCOM, as well as the application of process enhancements in PACOM and EUCOM.

### **TEST & EVALUATION ACTIVITY**

This year, the enhanced process improvements were tested at additional PACOM (February 2001) and EUCOM (April-May 2001) locations. The test team is now in the process of coordinating the global test with the warfighter and the defense activities providing support. In addition, the War on Terrorism may warrant the use of “Tiger Teams,” formed from the JT&E staff, to apply lessons learned in the processes used on new distribution pipelines supporting future operations.

### **TEST & EVALUATION ASSESSMENT**

The resources and planning for the JTD JT&E are adequate to meet the stated purposes of an OSD JT&E program. Data continues to be collected and analyzed. The CINCs and the Services continue to support the project. Participation by the field activities visited by the JTD JT&E personnel has been outstanding. Analysis of the baseline process mapping has identified several potential areas ripe for efficiencies to be gained. Early test treatments have been targeted toward the more obvious efficiencies to be gained. The full impact of test treatments will not be confirmed until the test is complete in FY03. However, in the interim it would be prudent to determine the appropriate agency to apply the recommended changes and direct implementation of known improvements to the joint theater distribution process.

## JOINT WARFIGHTERS (JWF)

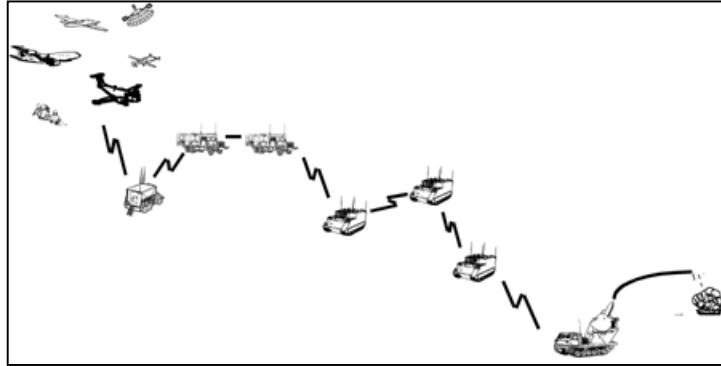

The charter of the Joint Warfighters (JWF) Joint Test and Evaluation (JT&E) project is to investigate, evaluate, and improve the operational effectiveness of joint operations against time-sensitive surface targets (TSST) by evaluating and documenting current time-sensitive surface target processes and procedures in realistic operational scenarios. Potential improvements will be identified, prioritized, and coordinated with the appropriate commands.

For Joint Warfighter JT&E, the Army, Navy, Air Force, Marine Corps, and unified commands are designated as participating Services/commands, with the Army designated as the lead Service and executive agent.

### **BACKGROUND INFORMATION**

Targeting in general, and the prosecution of time-sensitive targets in particular, was often cited as deficient in nearly all reports on the Persian Gulf War. One of many examples of this issue is demonstrated by the fact that the first Army Tactical Missile System (ATACMS) ever fired in combat was delayed hours, in part, while appropriate clearance was coordinated by all of the various nodes. While procedures were refined during the course of the war, it was not unusual for subsequent firings to be delayed up to two hours for clearance.

JWF participated in Ulchi Focus Lens (UFL 99) Command Post Exercise (CPX) in the Republic of Korea in August 1999 to baseline the joint Time Sensitive Surface Target (TSST) prosecution process. In October 1999, Joint Warfighters began preparations for the UFL 00 test activity of the enhanced joint TSST process in the Korean Theater of Operations by analyzing the data collected during UFL 99. Enhancements were developed for implementation within the framework of the processes documented in the UFL 99 baseline test activity. Throughout the remainder of 1999 and through May 2000, JWF personnel worked with theater personnel from U.S. Forces Korea (USFK) (J3 and J6) and the Service components to refine, install, and test the following theater enhancements during UFL 00:

- TSST Information Network. This network provides functional positions the ability to coordinate laterally and share information quickly and accurately.
- TSST Guide. This guide is to be used as a ready reference of theater and component Tactics, Techniques, and Procedures (TTPs), capabilities, and reference materials.

- TSST Web Page and Server. The TSST Web Page is an extension of, and is linked to, the USFK/J3-OP web server to provide customized, near real-time information posting.
- Collaborative Tool. USFK/J6-IS has authorized the use of Microsoft NetMeeting version 2.11. The TSST Information Network provides the TSST functional positions the capability to coordinate in a more accurate, complete, and timely manner.
- Secure Conferencing. This provides the TSST Information Network a secure, bridged communication capability. Its primary functions are to provide lateral notification of TSST execution, notify members of the TSST Information Network of a collaborative session, and serve as backup tool for lateral coordination.

The TSST Network enhancements were configured on 20 stations at various centers. The network resided on the Global Command and Control System–Korea (GCCS-K) Wide Area Net (WAN) and included the use of NetMeeting as a collaborative tool and the TSST Web Page. To support the use of the enhancements, a NetMeeting set-up and user guide was prepared and given to the positions along with a TSST Guide outlining the TSST process and enhancements. The TSST Guide was also available on the TSST Web Page.

Blue Flag 00-2 was another opportunity for JWF to baseline the joint targeting process, this time for U.S. Central Command (USCENTCOM). Blue Flag 00-2 was held from March 1-9, 2000, with exercise play running March 5-8, 2000. Blue Flag 00-2 was a CPX to train the USCENTCOM joint air operations center battle staffs with limited involvement and support from the other USCENTCOM Service components. The exercise used a limited Southwest Asia scenario with ground forces in fixed, defensive posture.

### **TEST & EVALUATION ACTIVITY**

JWF used the preceding year to finalize data analysis and prepare reports for the UFL 00 exercise, the Blue Flag 00-2 exercise, and the JWF final report. Additionally, the team assisted in establishing the Joint Battle Damage Assessment, a follow-on JT&E, into future UFL scenarios.

### **TEST & EVALUATION ASSESSMENT**

As a direct result of this JT&E, several important changes in prosecuting the TSST mission were incorporated in USFK. The changes are being reviewed by other theaters of operation to determine implementation feasibility.



**PART VIII**  
**NON-MAJOR SYSTEMS**  
**OT&E**



## **NON-MAJOR SYSTEMS OT&E**

In accordance with Title 10, U.S. Code, Section 139, paragraph (b)(3), the Director, OT&E is the principle senior management official in the DoD responsible to “monitor and review all operational test and evaluation in the Department of Defense.” This includes the OT&E on smaller, non-major acquisition systems. Although several non-major systems such as those directly affecting major systems and those specifically directed by Congress are under direct oversight of DOT&E, the OT&E of most non-major systems are controlled by the Service OTAs.

The Service OTAs are responsible for OT&E on hundreds of small programs. Army ATEC is currently working on 122 ACAT III or below and the Navy OPTEVFOR retains 223. Air Force AFOTEC retains 137 ACAT III programs under their cognizance. This is in addition to the numerous ACAT III programs that are managed by the Air Force’s Air Combat Command, Air Mobility Command and Air Warfare Center. None of the Service OTAs are adequately funded for this work. With priority often going to the higher profile major acquisitions, the OTAs must balance many competing demands for very scarce resources.

These small programs represent some of the best examples of integrated T&E demonstrating very effective processes to more rapidly field new military equipment. Often these processes are aggressive applications of the Secretary’s themes we have urged now for five years—early involvement by the operational testers, combining DT with OT, and combining testing and training. We are using successful examples from smaller programs to encourage the larger major system acquisitions to take advantage of the benefits of these themes.

One example of non-major system OT&E reported this year was the Deployable Power Generation and Distribution System (DPGDS). A description of the T&E conducted by AFOTEC follows.

### **SYSTEM DESCRIPTION**

The DPGDS is the proposed replacement for existing Harvest Falcon/Eagle power generation systems. It is designed to connect to existing elements of the secondary power distribution system to provide electrical power to a 1,100 person bare base camp. The DPGDS is designed to reduce theater airlift sortie requirements for mobile generation by at least 25 percent (key performance parameter). Other system requirements include improvements in overall efficiency, reliability, durability, and maintainability.

### **TESTING CONCEPT/METHODOLOGY**

The QOT&E and subsequent Deficiency Report Verification Tests (DRVT) were conducted at operationally representative conditions at Holloman AFB, New Mexico. Task qualified Air Force and Army personnel set up and operated the system in a variety of real world configurations and scenarios involving billeting, functional area tents, and base utility systems. Operators were tasked to set up, run, and maintain the system over a 30-day QOT&E and two subsequent DRVTs covering another 30 days of operation each.

## NOTABLE RESULTS

DPGDS was rated as operationally effective but not suitable. It passed the 25 percent airlift sortie reduction requirement, easily handled large load fluctuations and maintained stable power output in the automatic mode. However, the number of operational mission failures encountered during QOT&E was unacceptable, approximately one every 11 hours. The logistics supportability (including commercial technical manuals) was unacceptable in all areas assessed.

## CONTRIBUTION/INFLUENCE QOT&E HAD ON THE PRODUCTION DECISION

DPGDS would have been operationally limited if fielded prior to resolution of the software, hardware, and suitability deficiencies identified during QOT&E. As a result, the system now provides users with greater flexibility, reliability, safety, and life cycle cost reductions.

## LESSONS LEARNED/TEST LIMITATIONS

Provide for a more operationally realistic DT&E with greater operational tester and user participation right from the start. If done, many of the identified deficiencies (software, isolation issues, overheat conditions) may have been solved early, eliminating the need for additional testing after QOT&E. Communications between subject matter experts and system requirement developers is essential. During QOT&E, the users (Army and Air Force) identified new requirements not clearly defined in the original requirements documents causing extensive system changes and a year program slip.

The following tables document some of the other non-major systems OT&E activities conducted by the service OTAs. (These tables are limited to those T&E activities reported in FY01 that were intended to support full-rate production decisions.)

<b>AIR FORCE</b>					
<b>SYSTEM NAME</b>	<b>ACAT</b>	<b>TEST DATES</b>	<b>EFFECTIVE</b>	<b>SUITABLE</b>	<b>SURVIVABLE</b>
Advanced Technology Anti-Gravity Suit	III	9/00-1/01	NO	NO	N/A
Clear Radar Upgrade	III	12/00-1/01	YES	YES	N/A
Defense IEMATS Replacement Command and Control	III	1/ 01	YES	YES	N/A
Deployable Power Generation and Distribution System	III	7/00-8/00	YES	NO	N/A
GPS Enhanced Navigation System, C-141	III	11/99-7/00	YES	YES	N/A
Next Generation Small Loader	III	5/01	YES	Potentially	N/A
T-38 Avionics Upgrade Program	III	6/00-2/01	YES	Potentially	N/A

ARMY					
SYSTEM NAME	ACAT	TEST DATES	EFFECTIVE	SUITABLE	SURVIVABLE
(CABS) - OH-58D Cockpit Air Bag System	III	6/00-7/00	YES	YES	YES
(CABS) UH-60 DO Cockpit Air Bag System	III	11/00	YES	YES	YES
(AKMS) LUT Automated Key Management System	III	2/00-8/00	NO	NO	Not evaluated
(LRAS3) LUT Long Range Advance Scout Surveillance System	III	8/00	YES	YES	Not considered an issue
(TWS-OMNI) Night vision Thermal systems - Thermal Weapon Sight	III	3/00-4/00	YES with limitations	YES with limitations	YES with limitations
Joint Biological Point Detection System (JBPDS)	III	5/00-6/00	NO	NO	NO
(MOLLE) Modular Lightweight Load-Carrying Equipment	III	8/00-11/00	YES with Limitations	NO	Not evaluated
(CBPS) Chemical Biological Protective Shelter	III	10/00-11/00	Partially	NO	NO
(MDS FOTE) Modular Decontamination System	IV	3/01-4/01	NO	NO	NO
(EPJS PH II) Extraction Parachute Jettison System	III	4/01-7/01	YES	YES	Not considered an issue
(PIAFS) Portable Inductive Artillery Fuze Setter	III	6/00	YES	YES	YES
(CABS) UH-60 DO Cockpit Air Bag System	III	11/00	YES	YES	YES
(LLDR) Lightweight Laser Designator Rangefinder	III	4/01-5/01	YES with shortcomings	NO	Not suitable in NBC environment, suitable in conventional environment
(PG BLK I) Prophet Ground IOTE	III	10/00-12/00	YES in low intensity environments	YES	Partially Survivable
(ARL LUT I) Airborne Reconnaissance Low	III	3/01-4/01	Partially	Marginally	N/A

NAVY					
SYSTEM NAME	ACAT	TEST DATES	EFFECTIVE	SUITABLE	SURVIVABLE
Distributive Explosive Technology Program	III	10/00-11/00	Potentially Not	Potentially Yes	N/A
EX 8 Mod 0 Marine Mammal System	IVT	10/01-11/01	N/A DT Assist	N/A DT Assist	N/A
Non Gasoline Burning Outboard Engine	III	1/99-101	N/A DT Assist	N/A DT Assist	N/A
Acoustic Intercept Receiver	III	10/00-2/01	Potentially Yes	Potentially Yes	N/A
TB-29A BQ Thin Line Towed Array	III	8/00-3/01	Potentially Yes	Potentially Yes	N/A
Computer Aided Dead Reckoning Tracer	IVT	3/01	N/A DT Assist	N/A DT Assist	N/A
Submarine High Data Rate Antenna	IVT	3/01-4/01	Yes	Yes	N/A
Swimmer Transport Device	III	2/01-6/01	Yes	Yes	N/A
EX 8 Mod 0 Marine Mammal System	IVT	5/01-6/01	Yes	Yes	N/A
Submarine External Communications System	None	6/01-8/01	Potentially Yes	Potentially Yes	N/A
Computer Aided Dead Reckoning Tracer	IVT	6/01-8/01	Yes	Yes	N/A
Low Probability Intercept Altimeter	IVT	10/00-12/00	Potentially Not	Potentially Yes	N/A
F-14 Digital Flight Control System	III	7/00-10/00	Yes	Yes	N/A
S-3B Communications Improvement Program	IVT	6/00-12/00	Yes	Yes	N/A
Terrain Awareness and Warning System	IVT	10/00-11/00	Yes	Yes	N/A
Traffic Alert and Collision Avoidance System	IVT	10/00-11/00	Yes	Yes	N/A
Tactical Aircraft Moving Map Capability	III	10/00-1/01	Yes	Yes	N/A
P-3 Command Function Select Software	III	3/01-6/01	Yes	Yes	N/A
Super Barricade System	None	11/00	Potentially Not	Potentially Not	N/A
Joint MILCATCOM Network Integrated Control System	III	11/00	Yes	Yes	N/A
Financial Air Clearance Transportation System	IVT	8/00-11/00	Yes	Yes	N/A
Tactical Environmental Support System/NITES 2000	IVT	2/01-3/01	Yes	Yes	N/A
Automated Digital Network System	III	5/01	Yes	Yes	N/A

<b>NAVY Continued</b>					
<b>SYSTEM NAME</b>	<b>ACAT</b>	<b>TEST DATES</b>	<b>EFFECTIVE</b>	<b>SUITABLE</b>	<b>SURVIVABLE</b>
EP-3 ARIES II Sensor System Improvement Program	IVT	8/01	No	Yes	N/A
Integrated Ship Controls	IVT	4/01-5/01	Potentially Not	Potentially Not	N/A

<b>MARINE CORPS</b>					
<b>SYSTEM NAME</b>	<b>ACAT</b>	<b>TEST DATES</b>	<b>EFFECTIVE</b>	<b>SUITABLE</b>	<b>SURVIVABLE</b>
Short Range Assault Weapon	III	2/00-6/00	YES	NO	N/A
Medium Tactical Vehicle Replacement (IOT&E I)	II	2/00-6/00	YES	NO	N/A
Thermal Weapon Sight - Medium	III	8/00-9/00	YES	YES	N/A
Anti-Personnel Obstacle Breaching System	IV-T	10/00-11/00	YES	YES	N/A
Mounted Data Automated Communications Terminal	IV-T	10/00	NO	NO	N/A
Medium Tactical Vehicle Replacement (IOT&E II)	II	1/01-3/01	YES	YES	N/A

Notes:

- 1) MCOTEAs and OPTEVFORs do not breakout Survivability for separate treatment. Survivability is addressed as a component of Operational Effectiveness.
- 2) Operational Effectiveness and Suitability findings above were reflective of the system at the time of test. The system presented for the MS-III full-rate production decision often has changes incorporated as a result of the IOT&E experience.

This Page Is Intentionally Left Blank



# **PART IX**

## **LIVE FIRE TEST AND AND EVALUATION (LFT&E)**



## **LIVE FIRE OVERVIEW**

Live Fire Test and Evaluation (LFT&E) was enacted into law by Congress in FY86 and requires realistic survivability and lethality testing on platforms and weapons to assure that major systems perform as expected and that combat forces are protected. The Federal Acquisition Streamlining Act transitioned responsibility for the Live Fire Test program to DOT&E in Fiscal Year 1995. LFT&E mandated in Title 10, Section 2366 has many similarities with Operational Test and Evaluation that is mandated in Section 2399 of the same Title. While operational testing assesses the suitability and effectiveness of our major defense programs, live fire testing is required to independently assess the survivability of the nation's major air, land and sea platforms and the lethality of its major weapons systems. Both programs also require realistic testing in realistic operational environments.

In FY01 the number of Live Fire Test oversight programs grew to an all-time high of just over 100. These programs are nearly evenly divided between weapons platform survivability and weapons lethality. Six programs completed live fire testing and reporting during this fiscal year:

- The MH-47E and MK-60K Special Operations Aviation (SOA), November 2000.
- The V-22 Osprey, November 2000.
- The XM1001 40MM Canister Cartridge, November 2000.
- The B-2 Bomber, January 2001.
- The DDG-51 Flight 1A, January 2001.
- The M2A3 Bradley Fighting System (BFVS), April 2001.

### **EXAMPLES OF LIVE FIRE CONTRIBUTIONS**

Live Fire Testing has produced major improvements in systems by making system designs more survivable and lethal and by improving tactics, doctrine, and battle damage repair procedures. The contribution of Live Fire Testing is illustrated by the following two examples.

#### **F-22 WING FUEL TANK HYDRODYNAMIC RAM LFT&E**

An F-22 RAPTOR aircraft component-level test was conducted in the fall of 1992 against a production-representative piece of the aircraft's wing, roughly 3 by 4 feet in size. The pre-test prediction indicated that the wing would fully survive the impact and resultant damage inflicted by the threat projectile. This prediction was generated over a period of several months using one of the most complex computer codes available for this purpose.

The target wing sections (intended to be filled with fuel in the operational aircraft) were filled with water to assure that the damage mechanism to be assessed, hydrodynamic ram due to impact, could be clearly observed and evaluated. Upon impact, the wing failed totally and would have resulted in the loss of the aircraft, had that design been operational. Critics of the program would consider this test a failure. It would have only been a failure if the design remained unchanged; however, successful design changes were subsequently made and tested.

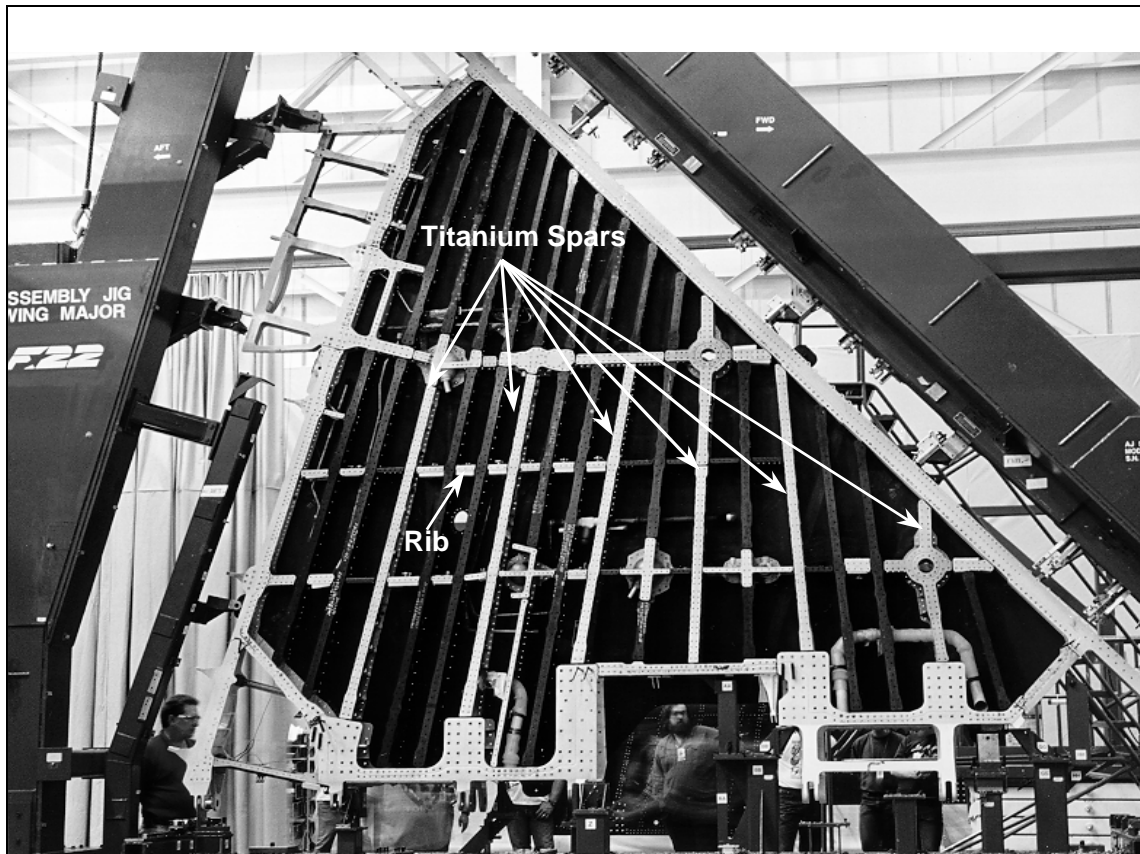

### **REDESIGNED F-22 WING WITH TITANIUM SPARS AND ADDITIONAL RIB**

The final live fire shot to assess hydrodynamic ram was conducted on August 22, 2001 against the newly designed wing, shown above. By replacing every third composite longeron with titanium one, the new design added the necessary strength to enable the aircraft to survive such a threat impact and reduced the vulnerability of the aircraft by roughly 50 percent. Furthermore, the aircraft survived the impact under tactical airflow and loads, and with its fuel tanks completely filled with jet fuel.

### **USS COLE: DDG 51 – ARLEIGH BURKE CLASS DESTROYER**

After the attack on the USS COLE, LFT&E personnel initiated an assessment of the causes of the casualties, their treatment, and other issues relating to the attack. The purpose was to collect information to identify procedures, designs and material changes, and other issues that could possibly help minimize casualties from any future attacks on these and other ships.

The Navy conducted at least four studies aimed at understanding the mechanism of the attack weapon, understanding the technical aspects of the structure of the ship and its ability to survive such a weapon, the operational nature of seamanship that affected the ship and her vulnerability to attack, and medical implications of the attack. DOT&E actively participated in the technical aspects of ship survivability design and the medical issues.

DOT&E concluded that certain additional design improvements to the ship class could improve crew survivability in the future. For example, the internal communication system would be less

vulnerable if a wireless system were employed to replace the current hard wire system. The failure mode logic and increased capacity of the pumps used for removing water from flooded spaces should be considered. Flooring material tends to shatter into glass-like shards that cause injury. Emergency water and rations should be available to provide nourishment to the crew in the case of power outage.

Autopsy and injury data indicated that the major cause of multiple blunt forces was flying metallic and non-metallic fragments. Although there was little fire associated with the damage to USS COLE, it was apparent that the weaknesses of the fire-fighting systems must be addressed to assure continuity of fire-fighting capability.

## **SPECIAL PROJECTS/INITIATIVES**

### **MODELING AND SIMULATION INITIATIVES**

LFT&E uses modeling and simulation in several ways, ranging from the immediate application of models to acquisition programs, to mid-term and long-term model development initiatives. These include:

- **LFT&E PRE-TEST MODEL PREDICTIONS:** Requiring pre-test predictions for each Live Fire and Joint Live Fire Program has added discipline to the T&E process. Comparing model predictions to test outcomes continues to provide valuable data to validate and improve our survivability/vulnerability/lethality models.
- **DEPARTMENT OF ENERGY (DOE) M&S:** Long-term model improvements are the objective of on-going LFT&E initiatives with the DOE National Laboratories to use and evaluate physics-based computer models. Since the LFT&E program is “test data rich” and Labs are “model rich,” this effort has been mutually beneficial. DOE’s high performance computing capability models have the potential to improve the understanding of system-level behavior by more accurately modeling fundamental component and material behavior. Advanced computer codes of the Accelerated Strategic Computing Initiative are being used to help make pre-shot predictions for a variety of Live Fire Test and Joint Live Fire test opportunities.
- **MODELING AND SIMULATION PILOT PROJECT:** In an effort to embark on more Simulation Based Acquisition, in FY00, DOT&E initiated an M&S pilot project with each of the three Services. In FY01, each Service selected a candidate acquisition program for the pilot project. The Army selected their Common Missile Program. The Navy selected their Extended Range Guided Munitions (ERGM) and the Air Force selected their T-38 Avionics Upgrade Program. The purpose of this project is to develop a methodology that more efficiently and effectively guides the use of M&S to support acquisition.

### **LIVE FIRE TESTING AND TRAINING PROGRAM**

The FY01 Defense Appropriation included congressional funding to investigate alternative uses of simulation and training technology to support LFT&E. This initiative is the Live Fire Testing and Training (LFT&T) program.

The LFT&T Program directly supports the exchange of technology initiatives and opportunities among the live fire and training communities to better serve the warfighter. It also fosters the establishment of partnerships between the DoD and the civilian sector. The underlying LFT&T Program objectives are to enhance cost-effective testing and training and improve warfighting readiness. The program has funded twenty-five projects through FY01, totaling approximately \$25M since its inception. Several projects have already transitioned to operational sponsors and are providing direct benefits to the warfighter.

The LFT&T Senior Advisory Group (SAG) manages the LFT&T program. The SAG is chaired by DDOT&E/LFT and members are the commanders of the four Services' training and simulation agencies. The SAG reviews government, industry and academia project proposals, selects the most promising projects, reviews project progress and products, and assures that program goals and objectives are achieved.

Live Fire Testing is unique in that, apart from actual combat, it is the only source of realistic combat vulnerability and lethality data, battle damage repair procedures, and estimates of user casualties. This program takes that realistic data and combines it with training technologies and opportunities in a synergistic way.

The LFT&T Program funded a total of fifteen projects in FY01. A summary of the FY01 projects follows:

- **WEAPONS AIMPOINT ANALYSIS AND TRAINING TOOL:** Small arms weapons systems and their associated fire control systems are becoming increasingly more complex. Advanced fire control systems, currently under development, will allow gunners to deliver airburst munitions against targets that were previously considered in defilade and difficult to attack. As a result, there is a need to develop better methods of measuring gunner/weapon performance during testing and training activities, against various targets.



The testing and training communities currently rely on limited and expensive indirect methods to measure gunner and weapon performance. The tool developed in this project will provide new capabilities to validate ballistic models for complex fire control systems, gather real-time gunner/weapon aimpoint position data for stationary and moving targets, separate gunner errors from weapon system errors, and provide enhanced weapon aimpoint and tracking feedback.

- **MAN PORTABLE AIR DEFENSE SYSTEMS (MANPADS) TEST AND TRAINING RESULTS:** MANPADS shoulder-fired missiles are significant threats to national and allied aviation communities. MANPADS conferences and workshops have highlighted the need for more comprehensive data on the capabilities and effects of shoulder-fired missiles to meet analysis, testing and training requirements.

This project provides an essential conduit for the transfer of MANPADS live fire test data and information to DoD and other Government agencies not



directly involved in Live Fire Test programs (*e.g.*, Justice Dept., Airport Security Committee, and the National Security Council). The data collected during this project will be used to train warfighters, train test engineers, analysts, anti-terrorism specialists and battle damage repair specialists involved in aircraft survivability and anti-terrorism activities.

- **SYNERGISTIC EFFECTS OF ALMOST-LOSS-OF-CONSCIOUSNESS (A-LOC):**

The effects of gravity-induced loss of consciousness (G-LOC) and loss of situation awareness (SA) have been widely studied as a

contributing factor in aircraft mishaps and pilot fatalities.

Most recently, significant attention has turned to the physiological phenomenon termed Almost-Loss-of-Consciousness or A-LOC. During A-LOC episodes, aviators may not lose total consciousness, but may experience significant sensory, motor, and cognitive impairment from acceleration that could lead to loss of both aircrew and aircraft. A better understanding of A-LOC is required to improve the Services' aviator physiological/acceleration training programs.



The objectives of this project are to enhance the Air Force and the Navy centrifuge training programs, to improve A-LOC prevention, and reduce the incidence or severity of A-LOC episodes to include prevention of aircraft mishaps that result from A-LOC. The results of this project will offer insight into mitigating risks and loss of life through improved training for Air Force and Navy high-performance aircraft aircrews.

**MOVING WEAPONS PLATFORM SIMULATOR (MWEPS):** The testing of stabilized, mounted weapons is complicated, costly and often provides only subjective results. Platform and logistics costs, range availability, data collection time, and ammunition costs are all factors that drive testing costs and effectiveness. Both initial and weapon systems proficiency training are similarly affected by these factors. An integrated simulator with actual hardware, computer-generated visual scenes, and objective performance scoring and feedback capabilities is essential to overcome limitations of live fire exercises. The tool/simulator developed from this project will allow weapons concepts to be evaluated earlier in the design process; reduce the live fire range time requirements; and serve as an individual weapons operator training system.



- **VIRTUAL TARGET GUNNERY SYSTEM:**

Testing and training activities require targets that are realistic in appearance and behavior. The project will significantly enhance live fire target technology by presenting intelligent, simulated targets to trainees learning to use the Mark 38 25-mm machine gun. These simulated targets will be presented in a real world setting, with the targets integrated in real time into the gunner's real-world view.



The use of simulated targets will:

- Provide realistic target signatures (visual, thermal, infrared, acoustic).
  - Accommodate non-line-of-sight, beyond-line-of-sight engagements.
  - Accurately replicate buildings, bunkers and other infrastructures.
  - Realistically represent threat, friendly, non-combatant and neutral behaviors.
  - Realistically simulate target vulnerability across a wide range of effects (electronic, lethal, non-lethal, etc.)
- **AUGMENTED REALITY (AR) FOR SHIP SURVIVABILITY:** This project examines the feasibility of using AR-based survivability technologies in shipboard testing and training environments. Specifically, investigations into various display and tracking technologies were evaluated and developed to demonstrate the capability to overlay realistic artificial fire, smoke, and extinguishing images onto images of the real world environment, including facilities, equipment, and other personnel.



A successful AR demonstration was conducted in June 2001 at the Navy Firefighter Training Facility in Mayport, FL. AR-based technology promises to provide improvements to existing shipboard fire fighting testing and training methods and capabilities through:

- Improved realism (e.g., images of real electrical fires versus propane simulation).
  - Reduced operational costs (e.g., propane and corrosion maintenance).
  - Dramatic safety improvements (e.g., elimination of potential explosion/explosive reflash), elimination of combustion byproduct--Carbon Monoxide/Formaldehyde, etc.)
  - Elimination of environmental concerns (e.g., no atmospheric emissions).
- **AUGMENTED REALITY (AR) FOR PLATFORM DAMAGE CONTROL:** Shipboard damage control testing and training faces the same technology limitations as described in the preceding project. Advances in AR-based technologies are needed to improve shipboard damage control testing, training realism and effectiveness, and allow more comprehensive testing of total ship response to damage.



This project builds on the results of the AR for Ship Survivability project and advance current and future AR-based technologies to meet shipboard damage control testing and training needs. Specifically, the project will continue the investigation and evaluation of various display and tracking technologies and will culminate with the development and demonstration of a ruggedized prototype AR-based damage control visualization system for testing and training purposes.



- **EXPLOITING LIVE FIRE TEST DATA:** Situation awareness is crucial to attack aircrews who must make time critical decisions that directly impact first-pass attack success, survivability, fratricide avoidance, and minimize collateral damage. Advances in real-time-in-the-cockpit (RTIC) technologies are needed to improve aircrew SA and overall probability of mission success.

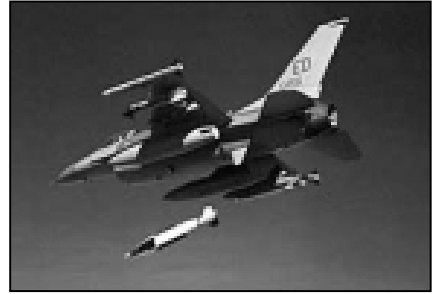

This project investigates the feasibility of integrating advanced technologies to provide RTIC information to the aircrews to improve overall situational awareness and probability of first-pass attack success. Information to be integrated includes look-up values from the Joint Munitions Effectiveness Manuals (JMEMs), data from live fire and joint live fire tests, and information from intelligence and sensor sources. The effort includes the study of various algorithms and display technologies and will culminate with a proof-of-concept demonstration to show its operational, testing and training utility. The proof-of-concept will be designed for a specific host aircraft but will be applicable to aircraft from all military services.

- **SHIPBOARD INCIDENT MANAGEMENT:** Medical and non-medical personnel must be trained and exercised in first response procedures for incidents involving ship and systems damage and personnel injuries. This training is currently difficult to accomplish and, in some cases, is unrealistic. A better method and capability is needed to train and measure shipboard first response skills.



This project develops a prototype shipboard training system that has the capability to train first responders in the management of major casualty incidents, and support the development of ship vulnerability, survivability and recoverability metrics. The prototype system will be developed from existing or commercial-off-the-shelf software. The initial focus for the prototype system is the LPD-17.

- **VULNERABILITY / LETHALITY (V/L) METRICS:** Traditional V/L metrics often adversely affect simulation fidelity by directly assessing the impact on component damage without considering the impact on total system capabilities. This leads to unrealistic outcomes and results in poor analytical, testing and training models, and simulations. Mathematically sound V/L methodology is needed to improve V/L metrics to overcome these current modeling and simulation shortfalls.



This project provides a sound methodology and set of V/L metrics that will more accurately represent combat outcomes in both analytical and training simulations. Incorporation of the improved V/L metrics will provide for:

- Higher fidelity of V/L modeling and simulation results.
- More representative and realistic visual and damage effects.

- Improved analysis and understanding of the synergistic effects of munitions impacts.
- Better decisions regarding weapon systems optimization, training methods, tactics, force structure requirement and mission effectiveness predictions.

- **MISSILE WARNING SENSOR STIMULATOR (MWSS):** Electro-optical Missile Warning Sensors (MWS) and associated countermeasures are under development to counter the increasing light vehicle and man-portable anti-aircraft missile threat.

This project enhances the capability and utility of the MWSS prototype system developed by the Air Force Operational Test and Evaluation Center (AFOTEC). The improved production MWSS system was transitioned to the 46<sup>th</sup> Test Wing at Eglin AFB in September 2001. Its capabilities and utility were clearly demonstrated in recent testing where significant operational MWS deficiencies were identified.



- **VIRTUAL TARGET AND RANGE (VITAR) SYSTEM:** Carrier Battle Groups and Amphibious Ready Groups/Marine Expeditionary Units typically conduct combined training operations in the weeks before a forward deployment. These combined operations include live fire exercises. Suitable supplemental training alternatives to current live fire exercises are needed due to current range issues (e.g., Vieques, environmental hazards) and range limitations (e.g., inadequate footprint for advanced munitions).

This project provides a prototype system for conducting cost-effective live fire exercises and supplementary training to Navy units. The proposed VITAR system will have the capability to:

- Determine the position of an impact and transmit the data back over the horizon to a systems controller.
- Display the impacts on real maps over any simulated terrain or target.
- Operate as a stand-alone system, or interfaced with shipboard systems to provide real time feedback to the crew.
- Safely test long-range systems such as the Advanced Gun System (AGS), the Extended Range Guided Munitions (EGRM) and Barrage round.

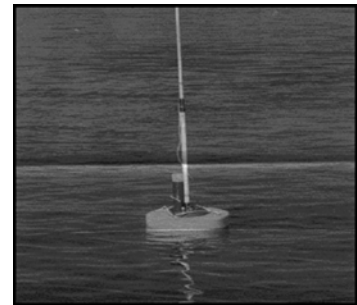

The VITAR system may not replace fixed ranges. However it will allow individual ships to conduct a wide selection of live fire training exercises almost anywhere at anytime. Additionally, VITAR will allow ships being sent to combat areas to perform live fire tests of their guns en route to ensure their accuracy and operational effectiveness.

VITAR completed successful demonstrations in July and August 2001. It has received strong endorsement from Navy senior leaders and a follow-on project has been proposed for FY02 to make the current prototype system fully operational.

- **DISMOUNTED INFANTRYMAN TESTBED (DISALT):** Current simulation testbeds are focused at the individual/weapon level. These stand-alone systems do not provide the

capability to examine the complex interrelationships and synergism of a fighting team employing multiple weapons.

This project provides a validated multi-user testbed that allows the live fire testing and training communities to analyze, and subsequently optimize, the lethality and survivability of a fighting team.



The DISALT system allows, for the first time, high fidelity testing of both weapon and human performance for both the individual and the fighting team in a validated simulation environment. Performance issues, such as weapon tracking, weapon handling, weapon effectiveness, weapon recoil, team and individual tactics, as well as communication and decision making skills, will all be directly measurable allowing for a total analysis of the lethality and survivability of the fighting team.

- **INFRARED TARGETS:** Forward Looking Infrared (FLIR) testing and training requires live fire targets that closely mimic the appearance of real infrared (IR) targets. The current approach to providing IR targets is costly and a more cost-effective means for providing IR targets is needed.

This project develops IR projection capabilities that will provide realistic live fire targets, with scoring capability, for FLIR testing and training. This will be accomplished by adapting commercial-off-the-shelf technologies.

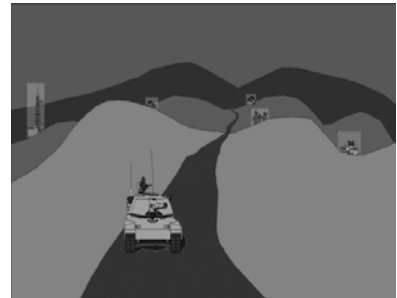

Computer-generated forces software will be adapted to provide control of the target imagery. The projection machinery will be hidden and protected behind berms to avoid damage by live fire. This project will provide improved IR target realism and meet FLIR testing and training needs of the both the Navy and Marine Corps. Additionally, it will provide cost saving over the current methods used to provide IR targets.

- **LIVE FIRE ADVANCED CONCEPTS:** Small unit, live team exercises are complex and inherently dangerous. This project explores how existing technologies and efforts can be leveraged to create a test bed that can be used as a fully immersive simulation environment for small unit leader, collective, and dismounted infantry testing and training. The simulation will create an environment that:



- Allows soldiers to maneuver throughout the battlefield, utilizing a head-mounted display to view the terrain and both friendly and opposing forces.
- Is weapon system independent (although initially focused on the Objective Individual Combat Weapon and M16).
- Can easily accommodate the addition of new individual or crew served weapons of the future.

- Facilitates the integration of other simulators and simulations into the scenario such as the Squad Synthetic Environment (located in the Land Warrior Test Bed at Ft. Benning, GA) or the Combat Trauma Patient Simulator (CTPS).

The immersive environment developed under this project will provide enhanced testing and training realism through the incorporation of 3-D audio and olfactory effects. The sight, sound and smell effects provided by the system will provide the soldier with a complete suite of sensory inputs to stimulate the human decision making process.

## **JOINT LIVE FIRE PROGRAM (JLF)**

The JLF program was chartered by OSD in March 1984, to conduct Live Fire Testing of fielded U.S. and foreign air and ground weapons platforms and munitions. The aircraft systems tested under the JLF program (known as the JLF Air Systems Program) are managed by the Joint Technical Coordinating Group for Aircraft Survivability (JTTCG/AS). Likewise, the Joint Technical Coordinating Group for Munitions Effectiveness (JTTCG/ME) manages the JLF Ground Systems Program.

In the fiscal year 2001 Air Systems Program, JLF testing addressed the vulnerability of the CH-47 Chinook, C-130 Hercules, F-16 Fighting Falcon and the lethality of the U.S. 20mm projectile PGU-28/B against selected foreign targets. In addition, FY01 efforts included continued development of Man-Portable Air Defense Systems (MANPADS) test technology to increase the amount of information gained from each shot.

Sea systems have not yet undergone JLF testing, but testing is planned with the Hellfire Missile against patrol boat targets, as described below.

- **MANPADS TESTING:** JLF's efforts in previous years included a limited number of firings of MANPADS missiles against targets, such as the F-14 and F-16, to obtain an understanding of the damage mechanisms produced by these threats as they interact with the targets.

Efforts to develop the rail launch techniques for foreign MANPADS testing continued during FY01. This launch method has the advantage of greater control over the impact conditions and greater safety in testing unreliable foreign MANPADS. During FY01, a rail launch test of an SA-16 was successfully conducted against an array of plates designed to represent an aircraft wing. Test objectives were to demonstrate the launch technique, and determine the penetration capabilities, fuzing distance, blast pressures, and fragment sizes/patterns for this foreign missile. The report is in review and will be published in FY02. A test with an SA-16 against an actual C-130 wing is planned for FY02.

- **CH-47D TESTING:** The CH-47D Chinook JLF program includes a series of ballistic tests and analyses to determine the vulnerability of the rotor blades and the rotor drive train system. The results of these tests will complement the ongoing LFT&E program for the CH-47F Improved Cargo Helicopter program, since the rotor blades and drive train are common to both variants. During FY01, static blades were shot with various projectile sizes and the damaged blades were subjected to fatigue testing. The results will be used to plan a limited number of ballistic tests against rotating blades to validate the results from the static tests.
- **C-130E/H TESTING:** The C-130E/H Hercules JLF program conducted ballistic tests and analyses to determine the vulnerability of the wing to hydrodynamic ram damage from

projectile impacts into the wing fuel tanks. The ballistic tests also provided an opportunity for Air Force C-130 Battle Damage Repair technicians and engineers to gain practical experience on a C-130 with realistic ballistic damage. The ballistic tests were conducted in FY00 and the report was prepared in FY01.

JLF is conducting an analysis to determine the types of damage that will result in a C-130 mission abort and the vulnerable area of the aircraft for those types of damage. In the C-130J and C-130AMP, a number of functions performed by the crew in older models have been automated and the crew size has been reduced. For ballistic damage that does not cause a loss of the aircraft, the question arises as to how well the newer models can tolerate with such damage and still complete their missions compared to the older C-130E/H models.

- **PGU-28/B LETHALITY TESTS:** The U.S. 20mm PGU-28/B SAPHEI (semi-armor piercing high explosive incendiary) projectile was developed in the mid 1980s (replacing the U.S. M-56A3 HEI projectile) for use in the air-to-ground role due to its armor penetrating capability. Since it provided significant performance improvements in terms of drag, effective range, time of flight, and graze angle tolerance, the round was selected for use against air-to-air targets in gunnery scenarios. The PGU-28/B is the only projectile currently used by the Air Force and Navy for fixed wing air-to-air combat. This projectile is fired from the M61A1 gun system that is utilized by the F-14, F-15, F-16, and F/A-18 aircraft. Current plans call for use of the PGU-28/B with the M61A2 gun system on the F-22 aircraft. With approximately 8,000,000 PGU-28/B rounds in the inventory, these tests will have a broad impact.

While the PGU-28/B represents an improvement in aerodynamic performance, its lethality (damage capability given a hit) against actual aircraft targets has not been demonstrated. Detailed plans were prepared to test the lethality of the PGU-28/B against a Soviet MIG-29 aircraft and a MIL-24 Hind Helicopter. The tests will be conducted in FY02.

- **HELLFIRE MISSILE/PATROL BOAT TESTS:** Planning began in FY01 for a test program of Hellfire missile shots against two Navy MK III Patrol Boats that are no longer in service. The objective of the tests is to assess the lethality of the Hellfire missile against patrol craft. FY02 planned efforts include the development of a detailed test plan, cost estimate, and preparation of pre-shot aim/hit point and damage predictions, including the detailed target modeling needed to do pre-shot predictions. Testing, which may not occur until FY03 because of limited FY02 funding, is to be conducted either off Wallops Island or in the Navy's Virginia Capes Operating Area.

## **JTCG/AS**

The Joint Technical Coordinating Group on Aircraft Survivability (JTCG/AS) ensures joint, coordinated development of survivability technology, methodology and design tools necessary to provide the Warfighter with survivable, combat effective aerospace systems. In FY01 the JTCG/AS Vulnerability Reduction subgroup funded over ten projects, with the goal of the development and application of technologies onto legacy and future aircraft to reduce their vulnerability and to increase the survivability of the crew. Two are described below.

- The Advanced Survivable Rotorcraft project, initiated in FY00 and completed in FY01, had as its objective a reduction in the vulnerability of rotorcraft to the MANPADS threat. The

project involved vulnerability analysis, structural hardening concepts, decoy concepts, possible sacrificial structural components, and baseline and improved survivability demonstration testing. This project has generated vulnerability reduction techniques for future rotorcraft systems.

- The Survivable Engine Control Algorithm (SECAD) project, initiated in FY99, has now matured to the point that a follow-on effort was initiated in FY01 to couple the SECAD technology to current engine health monitoring and prognostic (EHMP) technologies. The SECAD project conducted research and implemented engine software enhancements that are able to detect, identify and mitigate engine damage, possibly allowing pilots to reach their home base or at least friendly territory before ejection. This technology has been developed and implemented on an F/A-18E/F F414 test engine and may also be used to enhance the Joint Strike Fighter engine development program.

The JTCG/AS Susceptibility Reduction projects address the electro-optical and infrared threat missile systems, radio frequency homing missiles, and the use of flares to draw the threat away from the aircraft. Two of these projects are described below.

- A project to evaluate Aerogels as a retrofitted material for thermal and infrared emission suppression in and around aircraft engines was initiated. This technology shows tremendous potential to reduce the susceptibility of our air fleet to thermal seeking missiles.
- The Active Core Exhaust (ACE) project was funded jointly with the Air Force Research Laboratory, DARPA and private industry. This innovative project has as its focus the removal of the Core Thrust Reverser of the C-17 aircraft and replacing it with a redesigned nozzle incorporating a fully integrated pulsed injection system and plug nozzle. During the summer of 2000, ACE was tested on a C-17 engine test stand. A flight test will be conducted during this calendar year.

The JTCG/AS, in cooperation with the Joint Technical Coordinating Group for Munitions Effectiveness (JTCG/ME) and the Army Research Laboratory, developed a new physics-based simulation to assess the vulnerability of a wide range of targets as well as the lethality of many types of munitions. The Advanced Joint Effectiveness Model (AJEM) has the capability to calculate damage effects on a target system and determine the impact of that damage on the ability of the system to function. A milestone was achieved in FY01 with the release of AJEM version 1.0 to the user community. Work has begun on the next version.

## **JTCG/ME**

The JTCG/ME was chartered by the Joint Logistics Commanders (JLC) over 30 years ago to serve as DoD's focal point for authenticated non-nuclear munitions effectiveness information (Joint Munitions Effectiveness Manuals or JMEMs) on all U.S. major non-nuclear weapons. The JTCG/ME's mission includes validating, standardizing, and disseminating M&S methodologies for evaluating the lethality of our systems. The JTCG/ME, under the auspices of the JLCs, authenticates and publishes data for use in training, systems acquisition, weaponeering, procurement, and combat modeling. JMEMs are used by the Armed Forces of the United States, NATO and other allies to plan operational missions, support training and tactics development, and support force-level analyses. The JTCG/ME also develops and standardizes methodologies for evaluation of munitions effectiveness and maintains databases for target vulnerability, munitions lethality and weapon system accuracy.

In FY01, the JTCG/ME executed the following:

- Conversion/updates of the following JMEMs to CD-ROM format: JMEM Air-to-Surface Weaponeering System (JAWS) v2.2; Joint Anti-air Combat Effectiveness – Air Defense (J-ACE: AD) v2.0; Joint Anti-air Combat Effectiveness - Air Superiority (J-ACE: AS) v2.0; Joint Anti-air Combat Effectiveness - Ship Anti-air Warfare (J-ACE: Ship AAW) v1.0; JMEM/Surface-to-Surface Weaponeering Effectiveness System (JWES) v2.0 and Target Vulnerability Manual v2.2 on JAWS.
- Distributed products via the classified Internet with the JTCG/ME Products and Information Access System (JPIAS) v2.0.
- Expansion of existing databases to incorporate weapons effectiveness and target vulnerability data (e.g., Air-to-Surface Basic Manual – Revision, Surface-to-Surface Direct/Indirect Fire, Air Target Geometry, Joint Component Vulnerability Archive (JCVA) and delivery accuracy).
- Technical coordination efforts to address Target Vulnerability data generation (e.g., industrial targets, Non-Nuclear Consumables Annual Analysis (NCAA) targets, small boats, building structures, SATCOMs and TBMs) and methodology improvements (e.g., counter proliferation, titanium fragment penetration/equation standardization, Operational Requirements-based Casualty Assessment (ORCA) extension, and target model generation).
- Development of standardized models and methodology for Air-to-Surface, Surface-to-Surface and Anti-air effectiveness calculations (i.e., Collateral Damage Module (CDM), Hardened Targets Module (HTM), Building Analysis Module (BAM), Bridge Analysis System (BAS), Joint Anti-Air Model (JAAM), JAWS Target Acquisition, Joint Smart Weapons Module (JSWM), GPS accuracy and Multiple Weapon Types (MWT)).
- Configuration Management/VV&A on specific JTCG/ME models (i.e., JSEM, AJEM, MEVA-GF, MUVES-S2, BEAMS/ABEL, GENESIS-BAT, PENCURV-3D, ORCA, Joint MAE, and ASAP).
- Released Advanced Joint Effectiveness Model (AJEM) v1.x (Generalized Body-to-Body and Internal Blast), and Joint Component Vulnerability Archive v1.x together with the JTCG/AS.
- Continued CINC data call and prioritization in support of FY02 program build and Operation Infinite Justice in coordination with J8.
- Facilitated development and publication of National Disclosure Policy and classification review of the JAWS CD-ROM to address requirements for coalition operations.

## **VULNERABILITY ASSESSMENT TO RADIO FREQUENCY THREATS**

One of the roles of the LFT&E program is to assure that realistic testing is conducted using both current and future threats. This means both ballistic and non-ballistic directed energy threats. There is a growing concern that as the U.S. becomes dependent upon computer-driven command and control and, as military digitization becomes the norm, the possibility exists for a terrorist or rogue nation to seek to take advantage of this apparent dependency. LFT has supported the development of prototype high-power microwave (HPM) weapons and tests of these devices at DoD open-air ranges since FY97. As a result of these efforts, we now have some relevant equipment and experience with live fire testing of HPM weapons against military systems and commercial infrastructure.

The U.S. Congress provided an initial increment of \$4.0 million in FY99 to "expand threat vulnerability testing and evaluation to include the threat of radio frequency (RF) weapons." These funds supported the development of a RF device, using components and technology from the open market, as well as the conduct of various tests. A testing program was initiated to assess the potential vulnerability of electronic systems representative of the U.S. military and commercial infrastructure to HPM/ultra wideband illumination under "operationally relevant" conditions.

Two different RF devices were tested against targets, which included both a military weapon system (AH-1W Cobra) and commercial off-the-shelf (COTS) technology. The COTS equipment was subdivided into two distinct sets: (1) industrial control and monitoring technology (telephone switching technology, an x-ray baggage screening device, portable power generators, and uninterruptible power supplies); and (2) medical equipment

Additionally, live fire, open-air test was conducted using the F-16B, Block 15 as the test target. Two different RF devices were employed, each varying in waveform characteristics, rise time, pulse repetition frequency, burst length, and power level, in the testing. Complete data from the test are still being analyzed.



Results from the vulnerability assessment program so far have shown that, within the confines of the conditions tested and the given parameters evaluated, some systems are more vulnerable to HPM and RF electromagnetic energy than others. The overall conclusion is that hardened systems are hard and soft systems are soft. Military weapon systems are more hardened and, as a result, less vulnerable than COTS technology,

This series of tests showed it is unlikely that terrorists, without the support of a sophisticated engineering capability, would be able to develop a RF device using components and technology from the open market. A sophisticated engineering capability is essential to design, acquire, and integrate available technology to produce an effective operational RF threat weapon system. U.S. contractors developed the RF systems that were developed and used to support these tests with an engineering capability. The systems did not produce an unexpected effect against the targets used in these tests. Military systems are hardened and routinely tested for electromagnetic environmental effects (E3) prior to fielding.



# **INDEX OF PROGRAMS**



## INDEX OF PROGRAMS

ABRAMS TANK (M1A2).....	III-1
ADVANCED AMPHIBIOUS ASSAULT VEHICLE (AAAV) .....	IV-1
ADVANCED COMBAT DIRECTION SYSTEM (ACDS) BLOCK I.....	IV-5
ADVANCED DEPLOYABLE SYSTEM (ADS).....	IV-7
ADVANCED EXTREMELY HIGH FREQUENCY (AEHF) SATELLITE COMMUNICATIONS SYSTEM.....	V-1
ADVANCED FIELD ARTILLERY TACTICAL DATA SYSTEM (AFATDS).....	III-5
ADVANCED INTEGRATED ELECTRONIC WARFARE SYSTEM (AIEWS) AN/SLY-2(V) .....	IV-9
AH-64D LONGBOW APACHE & LONGBOW HELLFIRE MISSILE .....	III-7
AIM-120 AMRAAM .....	V-3
AIM-9X SIDEWINDER AIR-TO-AIR MISSILE.....	IV-11
AIR FORCE MISSION SUPPORT SYSTEM (AFMSS) .....	V-5
AIRBORNE LASER (ABL) .....	V-7
AIRBORNE MINE COUNTERMEASURES RAPID AIRBORNE MINE CLEARANCE SYSTEM (RAMICS) AIRBORNE MINE NEUTRALIZATION SYSTEM (AMNS) .....	IV-13
ALL SOURCE ANALYSIS SYSTEM (ASAS) .....	III-11
AMPHIBIOUS ASSAULT SHIP (REPLACEMENT) (LHA (R)) .....	IV-17
AMPHIBIOUS TRANSPORT DOCK SHIP (LPD 17) .....	IV-19
ARLEIGH BURKE (DDG 51) CLASS GUIDED MISSILE DESTROYER WITH THE AEGIS WEAPON SYSTEM, AN/SPY-1D/D(V) RADAR AND AN/SQQ-89(V) INTEGRATED SURFACE SHIP ANTI-SUBMARINE WARFARE COMBAT SYSTEM .....	IV-23
ARMY MULTIFUNCTION INFORMATION DISTRIBUTION SYSTEM LOW VOLUME TERMINAL 2 (MIDS-LVT 2) .....	III-13
ARMY TACTICAL MISSILE SYSTEM (ARMY TACMS) BLOCK II / BRILLIANT ANTI- ARMOR (BAT) .....	III-15
B-1B CONVENTIONAL MISSION UPGRADE PROGRAM (CMUP).....	V-11
B-2 SPIRIT.....	V-15
BATTLEFIELD COMBAT IDENTIFICATION SYSTEM (BCIS) .....	III-19
BRADLEY FIGHTING VEHICLE SYSTEM-A3 (BFVS-A3) .....	III-23
BUSINESS SYSTEMS MODERNIZATION (BSM) .....	VI-31
C-130 AIRCRAFT MODERNIZATION PROGRAM (AMP) .....	V-21
C-130J AIRLIFT AIRCRAFT .....	V-23
C-17 GLOBEMASTER III AIRLIFT AIRCRAFT .....	V-27
C-5 RELIABILITY ENHANCEMENT AND RE-ENGINEERING PROGRAM (RERP) .....	V-31
CH-47F IMPROVED CARGO HELICOPTER (ICH).....	III-25
CHEMICAL DEMILITARIZATION PROGRAM.....	III-29
COMANCHE (RAH-66).....	III-33
COMBAT SURVIVOR EVADER LOCATOR (CSEL) SYSTEM.....	V-33
COMPOSITE HEALTH CARE SYSTEM II (CHCS II) .....	VI-53

COOPERATIVE ENGAGEMENT CAPABILITY (CEC).....	IV-27
CRUSADER HOWITZER AND RESUPPLY VEHICLE.....	III-37
CVN(X) FUTURE AIRCRAFT CARRIER.....	IV-31
DD(X) LAND ATTACK DESTROYER.....	IV-33
DEFENSE CIVILIAN PERSONNEL DATA SYSTEM (DCPDS).....	V-37
DEFENSE INTEGRATED MILITARY HUMAN RESOURCES SYSTEM (DIMHRS).....	IV-35
DEFENSE JOINT ACCOUNTING SYSTEM (DJAS).....	VI-25
DEFENSE MEDICAL LOGISTICS STANDARD SUPPORT AUTOMATED INFORMATION SYSTEM (DMLSS AIS).....	VI-55
DEFENSE MESSAGE SYSTEM (DMS).....	VI-29
DEFENSE PROCUREMENT PAYMENT SYSTEM (DPPS).....	VI-27
DRY CARGO/AMMUNITION SHIP (T-AKE 1).....	IV-37
E-2 AIRBORNE EARLY WARNING (AEW) HAWKEYE 2000.....	IV-39
E-3 AIRBORNE WARNING AND CONTROL SYSTEM (AWACS).....	V-39
EA-6B UPGRADES.....	IV-43
EVOLVED EXPENDABLE LAUNCH VEHICLE (EELV).....	V-41
EVOLVED SEA SPARROW MISSILE (ESSM).....	IV-47
EX-171 EXTENDED RANGE GUIDED MUNITION (ERGM).....	IV-51
F/A-18 E/F SUPER HORNET.....	IV-53
F-15 FIGHTER DATA LINK (FDL).....	V-43
F-15 TACTICAL ELECTRONIC WARFARE SYSTEM..... (TEWS) (AN/ALQ-135 BAND 1.5).....	V-45
F-22 RAPTOR (ATF).....	V-49
FORCE XXI BATTLE COMMAND, BRIGADE AND BELOW (FBCB2).....	III-39
FORWARD AREA AIR DEFENSE COMMAND, CONTROL COMMUNICATIONS, AND INTELLIGENCE (FAAD C3I) SYSTEM.....	III-43
FUELS AUTOMATED SYSTEM (FAS).....	VI-33
GLOBAL BROADCAST SERVICE (GBS).....	V-55
INTEGRATED DEFENSIVE ELECTRONIC COUNTERMEASURES (IDECM) AN/ALQ-214.....	IV-57
INTERIM ARMORED VEHICLE (IAV).....	III-47
INTRODUCTION – JOINT TEST AND EVALUATION (JT&E).....	VII-1
JAVELIN ANTITANK MISSILE.....	III-51
JOINT AIR-TO-SURFACE STANDOFF MISSILE (JASSM).....	V-57
JOINT BATTLE DAMAGE ASSESSMENT (JBDA).....	VII-5
JOINT BIOLOGICAL POINT DETECTION SYSTEM (JBPDS).....	VI-37
JOINT CHEMICAL AGENT DETECTOR (JCAD).....	VI-41
JOINT CLOSE AIR SUPPORT (JCAS).....	VII-7
JOINT COMMAND AND CONTROL, INTELLIGENCE, SURVEILLANCE AND RECONNAISSANCE (JC2ISR).....	VII-9
JOINT COMPUTER-AIDED ACQUISITION AND LOGISTICS SUPPORT (JCALS) SYSTEM.....	III-53
JOINT CRUISE MISSILE DEFENSE (JCMD).....	VII-11
JOINT DIRECT ATTACK MUNITION (JDAM).....	V-61

JOINT GLOBAL POSITIONING SYSTEM COMBAT	
EFFECTIVENESS (JGPSCE) .....	VII-13
JOINT HELMET MOUNTED CUEING SYSTEM (JHMCS) .....	V-63
JOINT LAND ATTACK CRUISE MISSILE DEFENSE (LACMD)	
ELEVATED NETTED SENSOR SYSTEM (JLENS) .....	III-55
JOINT MARITIME COMMAND AND CONTROL CAPABILITY	
(JCC(X)) SHIP .....	IV-61
JOINT MISSION PLANNING SYSTEM (JMPS).....	IV-63
JOINT PRIMARY AIRCRAFT TRAINING SYSTEM (JPATS).....	V-65
JOINT SERVICES LIGHT NUCLEAR, BIOLOGICAL, AND CHEMICAL	
RECONNAISSANCE SYSTEM (JSLNBCRS).....	VI-43
JOINT SERVICES LIGHTWEIGHT STANDOFF CHEMICAL	
AGENT DETECTOR (JSLSCAD).....	VI-47
JOINT SHIPBOARD HELICOPTER INTEGRATION PROCESS (JSHIP) .....	VII-15
JOINT SIMULATION SYSTEM (JSIMS).....	III-57
JOINT STANDOFF WEAPON (JSOW).....	IV-65
JOINT STRIKE FIGHTER (JSF) .....	V-69
JOINT SUPPRESSION OF ENEMY AIR DEFENSES (JSEAD).....	VII-19
JOINT SURVEILLANCE TARGET ATTACK RADAR SYSTEM (JSTARS)	
E-8C AND COMMON GROUND STATION (CGS), MULTI-PLATFORM	
RADAR TECHNOLOGY INSERTION PROGRAM (MP-RTIP),	
MULTI-PLATFORM COMMON DATA LINK (MP-CDL).....	V-73
JOINT TACTICAL RADIO SYSTEM (JTRS).....	III-59
JOINT THEATER DISTRIBUTION (JTD).....	VII-21
JOINT WARFIGHTERS (JWF).....	VII-23
JOINT WARNING AND REPORTING NETWORK (JWARN).....	VI-49
LARGE AIRCRAFT INFRARED COUNTERMEASURES (LAIRCM) .....	V-77
LINE-OF-SIGHT ANTITANK MISSILE (LOSAT) .....	III-61
M829E3 120-MM APFSDS-T CARTRIDGE .....	III-63
MANEUVER CONTROL SYSTEM (MCS) .....	III-65
MEDIUM EXTENDED AIR DEFENSE SYSTEM (MEADS).....	VI-1
MH-60R MULTI-MISSION HELICOPTER UPGRADE.....	IV-69
MH-60S FLEET COMBAT SUPPORT HELICOPTER.....	IV-73
MILSTAR SATELLITE SYSTEM .....	V-79
MINUTEMAN III GUIDANCE AND PROPULSION REPLACEMENT	
PROGRAMS.....	V-83
MISSILE AND LASER WARNING SYSTEM, AN/AAR-47(V)2.....	IV-77
MK 48 ADCAP TORPEDO UPGRADES .....	IV-79
MULTIFUNCTION INFORMATION DISTRIBUTION SYSTEM –	
LOW VOLUME TERMINAL 1 (MIDS-LVT 1) .....	IV-81
MULTIPLE LAUNCH ROCKET SYSTEM (MLRS) M270A1 LAUNCHER.....	III-67
NATIONAL AIRSPACE SYSTEM (NAS) .....	V-85
NATIONAL MISSILE DEFENSE (NMD	
(GROUND-BASED MIDCOURSE DEFENSE).....	VI-3

NATIONAL POLAR-ORBITING OPERATIONAL ENVIRONMENTAL	
SATELLITE SYSTEM (NPOESS) .....	V-89
NAVSTAR GLOBAL POSITIONING SYSTEM (GPS).....	V-93
NAVY AREA THEATER BALLISTIC MISSILE DEFENSE (NATBMD).....	VI-9
NAVY EXTRA HIGH FREQUENCY SATELLITE	
COMMUNICATIONS PROGRAM (NESP).....	IV-83
NAVY MARINE CORPS INTRANET (NMCI).....	IV-85
NAVY STANDARD INTEGRATED PERSONNEL SYSTEM (NSIPS).....	IV-87
NAVY THEATER WIDE / SEA BASED MID-COURSE (NTW/SBMC).....	VI-13
PATRIOT ADVANCED CAPABILITY-3 (PAC-3).....	VI-17
PROPHET .....	III-69
RADAR WARNING RECEIVER (RWR) AN/ALR-56M .....	V-97
RADAR WARNING RECEIVER (RWR) AN/APR-39A (V)2.....	IV-89
RESERVE COMPONENT AUTOMATION SYSTEM (RCAS) .....	III-71
ROLLING AIRFRAME MISSILE (RAM) WEAPON SYSTEM .....	IV-91
RQ-1A PREDATOR UNMANNED AERIAL VEHICLE (UAV) SYSTEM.....	V-99
RQ-4A GLOBAL HAWK UNMANNED AERIAL VEHICLE (UAV) SYSTEMS.....	V-103
RQ-7 SHADOW 200 TACTICAL UNMANNED AERIAL VEHICLE	
(TUAV) SYSTEM .....	III-73
RQ-8A FIRESOULT VERTICAL TAKEOFF AND LANDING TACTICAL	
UNMANNED AERIAL VEHICLE SYSTEM (VTUAV) .....	IV-95
SEAWOLF SSN 21 CLASS ATTACK SUBMARINE	
AND AN/BSY-2 COMBAT SYSTEM .....	IV-99
SECURE, MOBILE, ANTIJAM, RELIABLE, TACTICAL	
TERMINAL (SMART-T).....	III-77
SENSOR FUZED WEAPON (SFW).....	V-107
SHIP SELF DEFENSE SYSTEM (SSDS) .....	IV-103
SPACE-BASED INFRARED SYSTEM (SBIRS) .....	V-111
STANDARD MISSILE-2 (SM-2) .....	IV-105
STANDARD PROCUREMENT SYSTEM (SPS).....	VI-35
STANDOFF LAND-ATTACK MISSILE EXPANDED RESPONSE (SLAM ER).....	IV-107
STINGER RMP MISSILE .....	III-79
STRATEGIC SEALIFT PROGRAM (SSP).....	IV-109
SUBMARINE EXTERIOR COMMUNICATIONS SYSTEM (SubECS) .....	IV-111
SUITE OF INTEGRATED INFRARED COUNTERMEASURES AND	
COMMON MISSILE WARNING SYSTEM (CMWS, AN/AAR-57)	
(SIIRCM/CMWS) INCLUDES: ADVANCED THREAT INFRARED	
COUNTERMEASURES (ATIRCM, AN/ALQ-212).....	III-81
SUITE OF INTEGRATED RADIO FREQUENCY COUNTERMEASURES	
(SIRFC) AN/ALQ-211.....	III-85
TACTICAL AIRCRAFT MISSION PLANNING SYSTEM (TAMPS).....	IV-113
THEATER HIGH ALTITUDE AREA DEFENSE (THAAD).....	VI-21
THEATER MEDICAL INFORMATION PROGRAM (TMIP) .....	VI-57
TOMAHAWK.....	IV-115
TOW FIRE AND FORGET (TOW-F&F).....	III-87

TRANSCOM REGULATING AND COMMAND & CONTROL	
EVACUATION SYSTEM (TRAC <sup>2</sup> ES) .....	V-115
TRANSPORTATION COORDINATORS' AUTOMATED INFORMATION	
FOR MOVEMENTS SYSTEM II (TC-AIMS II).....	III-89
UH-60M BLACK HAWK .....	III-91
USMC H-1 UPGRADES .....	IV-117
V-22 OSPREY .....	IV-119
VIRGINIA (SSN 774) CLASS ATTACK SUBMARINE .....	IV-123
WARFIGHTER INFORMATION NETWORK – TACTICAL (WIN-T).....	III-95
WIDE-AREA MUNITION (WAM) ADVANCED HORNET .....	III-97
WIDEBAND GAPFILLER SATELLITE (WGS).....	V-117

This Page Is Intentionally Left Blank







[www.dote.osd.mil](http://www.dote.osd.mil)